

Neles Easyflow™ pneumatic cylinder CC series (Ø200 – Ø350)

Installation, maintenance and
operating instructions

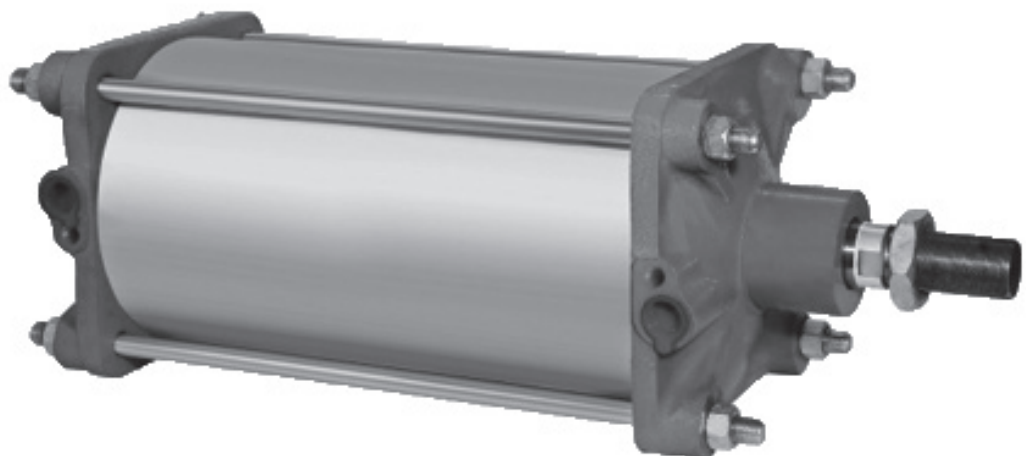

Table of contents

INTRODUCTION	3
Definitions	3
OPERATION PRINCIPAL	3
LABEL DESCRIPTION	3
INSTALLATION PROCEDURE	4
MAINTENANCE	5
TOOL KIT	5
DISASSEMBLY	5
Front cover disassembly	6
Piston disassembly	6
Rear cover disassembly	7
ASSEMBLY	7
Rear cover assembly	7
Piston assembly	7
Front cover assembly	8
EXPLODED VIEW	9
PACKAGING & STORE	10
ASSISTANCE	10

READ THESE INSTRUCTIONS FIRST!

These instructions provide information about safe handling and operation of the valve.

If you require additional assistance, please contact the manufacturer or manufacturer's representative.

SAVE THESE INSTRUCTIONS!

Addresses and phone numbers are printed on the back cover.

1. INTRODUCTION

Thank you for choosing Valmet product. Each product is fully inspected after the production to offer you the highest quality. In order to fully utilize the product, **we strongly recommend users to read this manual carefully and understood.**

This manual provides information on installation, operation and maintenance procedures and related instructions for the Neles™ pneumatic cylinder (CC series).

The aim of this literature is to support the use of products in correct manner, and all the technical information provided in the catalogue.

The manual should be given to the end user.

The manual can be changed or revised without any prior notice. Any changes in product's specification, structure, and/or any components may not result immediate revised version of the manual.

The manual should not be duplicated or reproduced for any purpose without any consent of Valmet Flow Control India PVT LTD

Manufacturer Warranty

For the safety, it is vital to follow instructions in the manual. It is not Valmet liability for any damages which caused by users' negligence.

It is not Valmet liability for any damages or accidents which resulted by any alteration or modification of the product and parts. If alteration or modification is necessary, please contact the Valmet directly.

Valmet warrants the product from the date of original retail purchase of the product for one (1) year, except as otherwise stated.

Valmet warranty will not cover the products that the product have been subjected to abuse, accident, alteration, modification, tampering, negligence, misuse, faulty installation, lack of reasonable care, repair or service in any way that is not contemplated in the documentation for the product, or if the model or serial number has been altered, tampered with, defaced or removed; damages that occurs in shipment, failure due to power surge, and cosmetic damage. Improper or incorrectly performed maintenance or report voids this Limited Warranty.

For detailed warranty information, please contact :
Valmet Flow Control INDIA PVT LTD, Manapada road, Dombivli (e), Maharashtra, India, Pin - 421204

1.1 DEFINITIONS

WARNING:

IF NOT OBSERVED, USER INCURS A HIGH RISK OF SEVERE DAMAGE TO PRODUCT AND/OR FATAL INJURY TO PERSONNEL.

CAUTION: IF NOT OBSERVED, USER MAY INCUR DAMAGE TO PRODUCT AND/OR INJURY TO PERSONNEL.

NOTE: Advisory and information comments provided to assist maintenance personnel to carry out maintenance procedures.

2. OPERATION PRINCIPAL

Pneumatic cylinder is a mechanical device which uses power of compressed air/gas to produce a force in a reciprocating linear motion.

The basic pneumatic cylinder consists of a cylindrical chamber with a movable piston and intake and exhaust channels.

Compressed air or other gas is supplied into the cylindrical chamber. This pressurized air/gas exerts force against the base of the piston, which causes piston to move, providing a way to move other mechanical elements.

3. LABEL DESCRIPTION

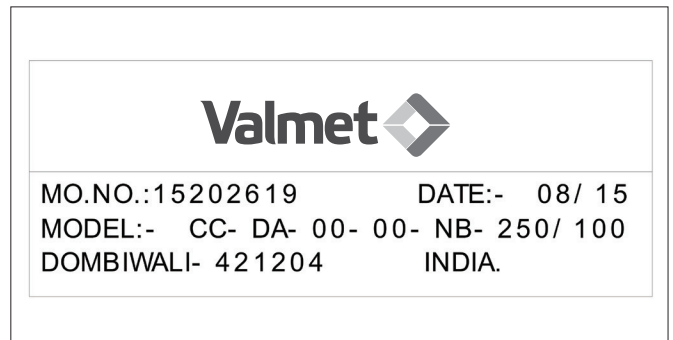

Label of the cylinder defines the precise feature of that particular cylinder. This description is written below the Valmet logo and is as follow.

M.O. NO.:	Manufacturing order number
DATE:	Date of manufacturing
Model no.:	CC – Type
	DA – Double acting cylinder
	00 – standard MOC of piston rod
	00 – Standard model
	NB – with NBR seals
	250 – Cylinder Bore dia. 250 mm
	100 – Stroke length 100 mm
Dombivli – 421204 INDIA:	- Brief address

4. INSTALLATION PROCEDURE

The equipment must be installed in the accordance with the laws, guide lines and rules applicable within the country.

As per ISO 8573 we required air quality as below.

1. Particle size < 5 μ (class 5)
2. Pressure dew point < -20°C (class 3) for actuator
3. Pressure dew point < -40°C (Class 4) for positioner
4. Concentration of total oil < 5 mg/m³

WARNING:

OPERATING CYLINDERS OVER TEMPERATURE OR PRESSURE LIMITS WILL RESULT IN DAMAGE TO CYLINDERS.

CAUTION: DO NOT DISMANTLE THE CYLINDER WHILE OPERATION IS IN LINE. DO NOT ALLOW DIRTY AIR OR FLUIDS TO GET INTO THE CYLINDER. USE FILTER UNIT (FILTER SIZE 40 μ m, 3°C) FOR DUST AND MOISTURE REMOVAL.

NOTE: Ensure the installation meets the legal and regulatory requirements of the country and state of use. The cylinder assembly should be left in the original packing until it is required for the use. The metallic pipe connections should be rinsed with degreasing or by grease dissolving liquids or agents, before being connected to our cylinder. Flush all pipes with 4 kgf/cm² air for at least 1/2 hour. Lubrication is not necessary. (Maintain once started oil mist lubrication. As per ISO 3448 recommended oils are NUTO H 32, VG 32. Oil viscosity 32 cSt at 40°C). Operating pressure range 1-10 bar. Operating temperature range -20°C to +80°C.

1. Pneumatic system is suitable for operation with compressed air between 1-10 bar. Usually the sizing is done at the air pressure availability confirmed by the client. (Hydraulic pressure maximum of 10 bar on request)
2. Hemp filaments, jute or even teflon ribbons are normally not required, As the part connections are accurately threaded. By chance, if any of these or any other tightening medium get into the operational area inside the cylinder, possible damage of the cylinder could not be ruled out.
3. The mounting holes size and bolt size circle are confirming to ISO 6431 / ISO 15552 norms. The threaded holes are ISO metric coarse and as ISO 6431 / ISO 15552. (Refer catalogue)
4. Clean all pipes and tube fittings thoroughly with suitable means. As even when brand new pipes are fitted, unclean interior are quite covered with dirt and dust.
5. Avoid impact on the cylinder. These may happen during transportation/ erection/ mishandling.
6. Align properly the rod axis with the load and direction of movement when connecting. If not properly aligned, the rod and tube may be twisted and damage may be caused due to wear on areas such as inner tube surface, bushing, rod surface and seals.

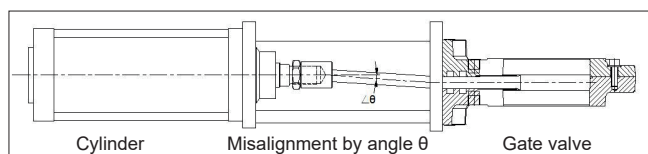

7. All accessories mountings of cylinders are well lubricated before dispatch. After removing pin and circlip store them in clean box. Install pin and circlips without damaging bore.
8. When an external guide is used, connect the rod end and the load in such a way that there is no interference at any point within the stroke.
9. Cushioning –

When stroke comes to an end, cushioning allows air to pass through cushioning port and thus decelerate the piston before it strikes the end cap which lowers the stresses on cylinder components and reduces vibration transmitted to the machine structure.

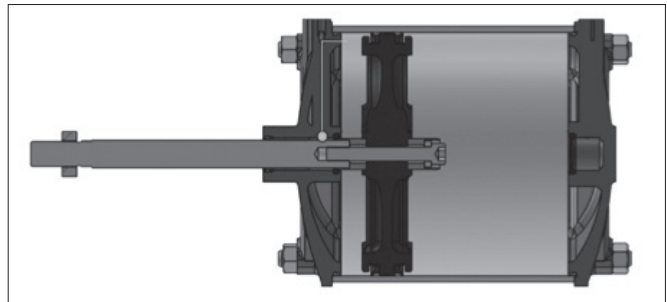

If cushioning is not provided then air passes through exhaust port only. When stroke comes to an end, piston strikes the end cover with some acceleration, giving rise to knocking noise, stresses on cylinder components and vibration transmitted to the machine structure.

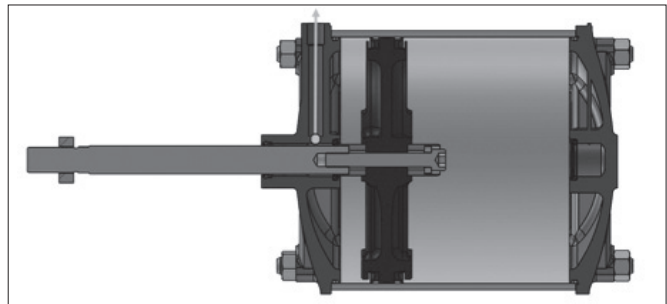

Perfect pneumatic cushioning produces minimal noise from end cover contact, and minimum piston deceleration time. To achieve perfect cushioning, ensure cushioning screw is full open at the time of installation. Operate cylinder in full forward to full back. Now keep on tightening cushioning screw till cylinder stops knocking. This will give maximum life to your equipment and to pneumatic cylinder.

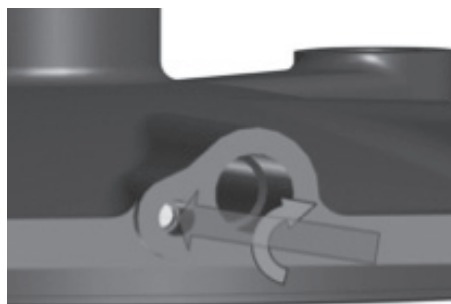

NOTE: In case of single acting cylinder, cushioning effect is observed in the chamber which is opposite to the spring chamber.

10. For perfect cushioning rotate the screw as shown in following table.

Bore Ø (mm)	200	250	300	350
No. of allowable rotation	6	6	6	6

Perfect cushioning shows graph as follow.

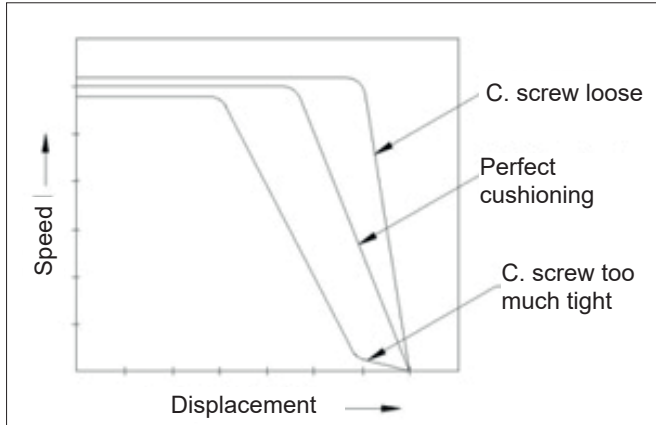

11. Select the seal material as per working temperature using following table.

Seal material	Min. Temp.	Max Temp
NBR	-20°C	+80°C
Viton	-20°C	+125°C

5. MAINTENANCE

NOTE: The cylinder must be removed from installation prior to maintenance. All the connections/ports have to be disconnected prior to disassembly. All the mountings, accessories and spare parts used or replaced must be original from NELES™.

Valmet recommends “Neles™ V09” grease for greasing. Wherever asked, use 7649 primer (dryer) for drying and 242 loctite for tightening effect. Apply the grease with soft brush or similar. In case of any difficulty consult Valmet distributor.

1. Install, operate and maintain as per the instructions and recommendations of this manual.
2. Any deviation from the above will cease the responsibilities of Valmet.
3. Verify the following things for that particular operation.

Failure	Verify	Remedy
a. Cylinder is not operating	1. Compressed air is not available	Make it available
	2. Side thrust is too high	Align the component properly
	3. Operating below the lower speed limit	Eliminate cause of lower load fluctuation
	4. Direction control valve is not operating	Make sure that the pressure and supplied voltage for direction control valve are as per rating
	5. Connected device (Gate valve, globe valve, damper, etc.) get stucked	Do maintenance of connected device
	6. Load factor is too high	Raise pressure or use larger cylinder
	7. Speed controller is meter-in control	Change to meter-out control
b. Cylinder operates too slow	1. Air pressure is insufficient	Check for the leakage and make it leak proof
	2. Air flow is insufficient	Check pressure drop on AFR gauge and make sure that tube sizes are proper

6. TOOL KIT

Tool	Ø Bore	200 Ø	250 Ø	300 Ø	350 Ø
1. Spanner for cover bolt		24 mm	30 mm	36 mm	36 mm
2. Allen key for SHC screw		14 mm	14 mm	17 mm	17 mm
3. Spanner for piston rod		36 mm	36 mm	36 mm	36 mm
4. Spanner for lock nut		55 mm	55 mm	55 mm	55 mm
5. Screw driver		8 - 10	8 - 10	8 - 10	8 - 10
6. Blunt needle		14g x 1"	14g x 1"	14g x 1"	14g x 1"

7. DISASSEMBLY

WARNING:

ALL ELECTRIC AND PNEUMATIC CONNECTIONS SHOULD BE REMOVED BEFORE STARTING DISASSEMBLY.

NEVER ATTEMPT TO REMOVE PISTONS FROM CYLINDER BODY USING AIR PRESSURE WHEN THE END CAPS HAVE BEEN REMOVED.

CAUTION: DO NOT PLACE DISMANTLED PART ON ANY DIARY/WORK BENCH BUT KEEP IT ON CLEAN PAPER/CLOTH IN SAME SEQUENCE AS YOU HAVE DISMANTLED IT.

NOTE: It is advisable to replace all the rubber parts using genuine Neles™ spare kit. Numbers in parentheses, () indicate the bubble number (reference number) used on the Neles™ Assembly details and Part List. For disassembly of single acting cylinder follow the sequence. For disassembly of double acting cylinder just ignore 1st step from heading 7.2. Piston disassembly, remaining sequence is same as given.

7.1 FRONT COVER DISASSEMBLY

1. Remove lock nut (7), Loosen the cylinder cover bolt (9) of front cover and remove it.

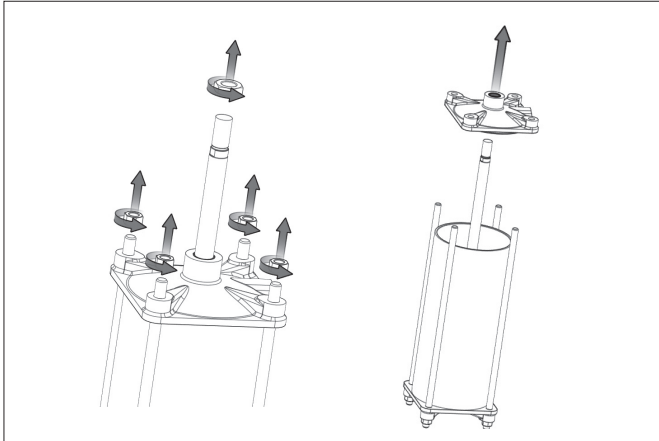

2. Remove rod seal (14) using screw driver.

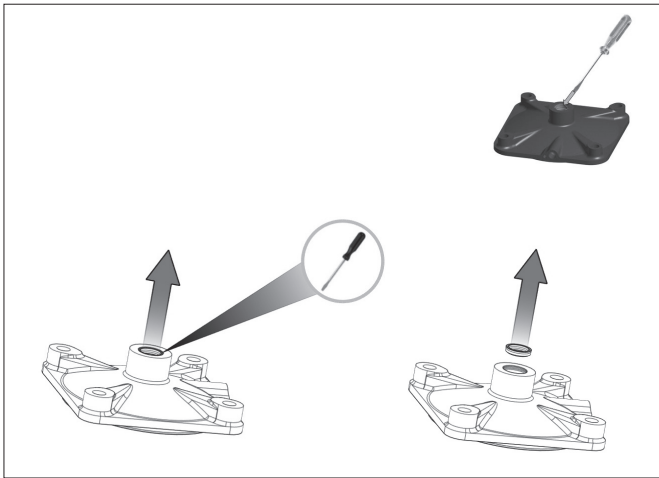

3. Remove o-ring (17) and cushion seal (15), take out cushioning screw (12) with o-ring (19) from front cover (1).

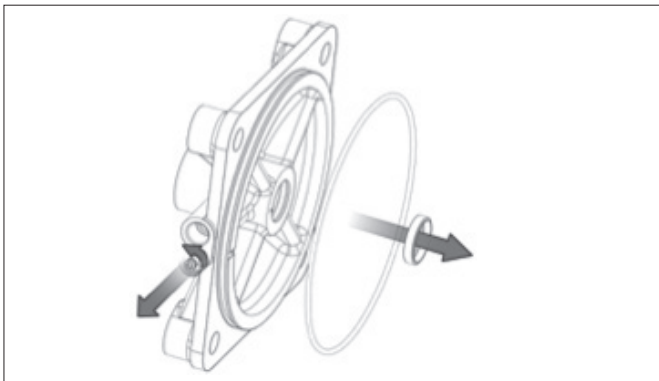

4. Clean it with liquid soap solution. After drying apply grease on

rubber parts. Replace these rubber parts.

5. Pull the piston rod (5) with piston subassembly outside the tube (3).

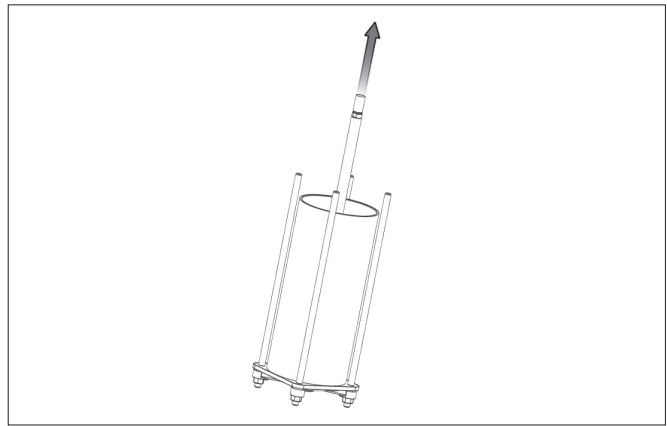

6. Just push tie rod (6) and take it away with cover nut (9) from rear cover (2).

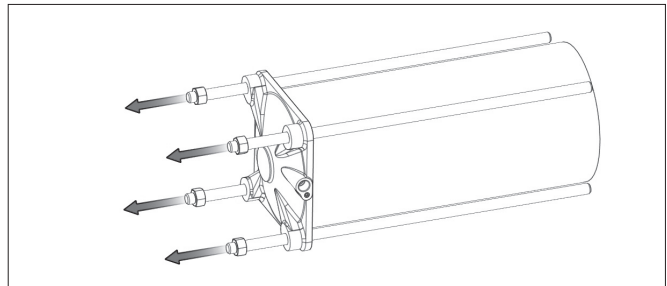

7.2 PISTON DISASSEMBLY

1. Take out SHC screw (8) from piston (4) to disassemble rod (5).

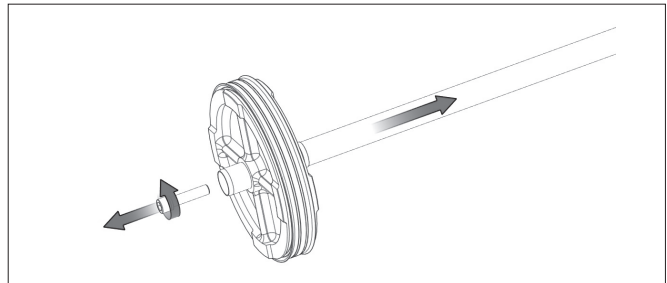

2. Remove lip seal (16) and buffer cap (10) from piston (4). Use blunt needle to remove lip seal (16).

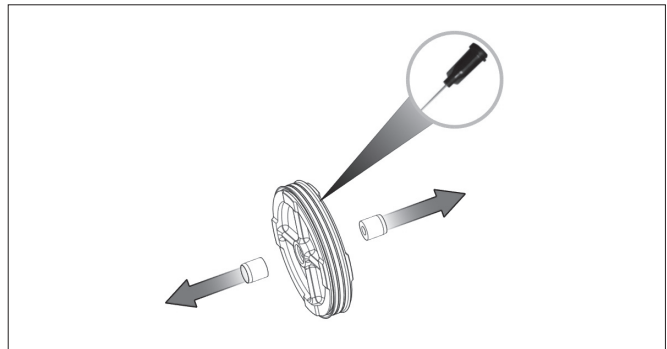

3. Observe damage of teflon strip(11), if necessary replace it.
4. Clean it with liquid soap solution. After drying apply grease on rubber parts. Replace these rubber parts.

7.3 REAR COVER DISASSEMBLY

1. Take out rear cover (2) from tube (3).

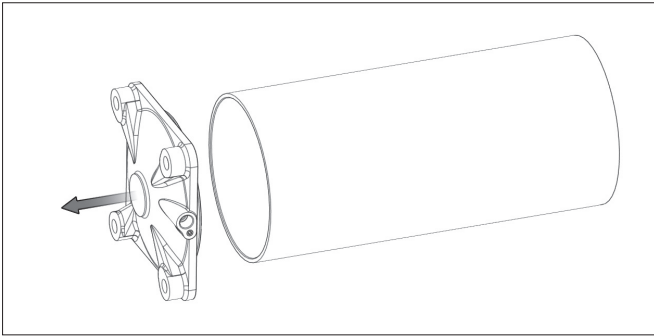

2. Remove o-ring (17) and cushion seal (15), take out cushioning screw (12) with o-ring (19) from the rear cover (2).

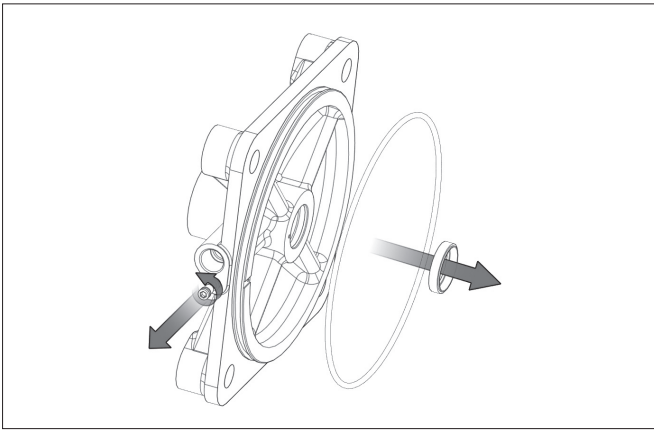

3. Clean tube (3) and rear cover (2) with liquid soap solution. After drying apply grease on rubber parts and inside the tube. Replace these rubber parts.

8. ASSEMBLY

NOTE: When assembling springs and end covers on cylinder, it is necessary to have the cylinder body in the vertical position. This is required to ensure that springs remain properly aligned and centred during assembly. For single acting cylinder follow the sequences as given below to ensure proper assembly. For double acting cylinder just ignore the 5th step in heading 8.2. Piston assembly follow the sequence to ensure proper assembly.

8.1 REAR COVER ASSEMBLY

1. Clean it with liquid soap solution. After drying apply Neles™ grease on rubber parts.
2. Place Cushioning seal (15) and o-ring (17) on its groove. Place o-ring (19) on cushioning screw (12), assemble the cushioning screw on rear cover.

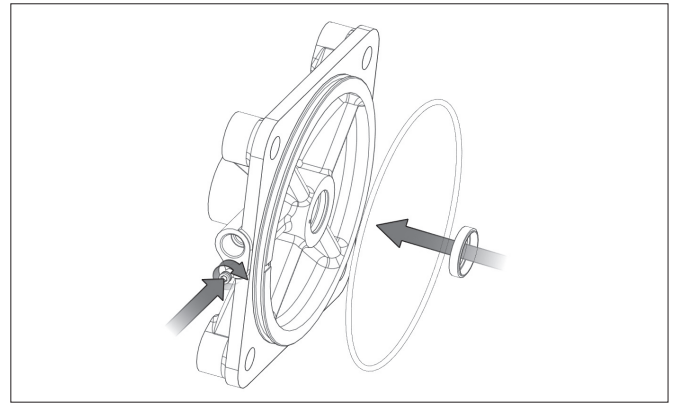

3. Place the rear cover (2) on tube (3).

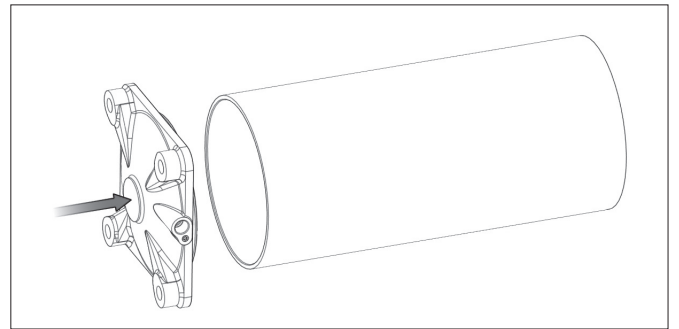

4. Assembled the cylinder cover nut (9) and tie rod (6) on rear cover (3) with tube (3).

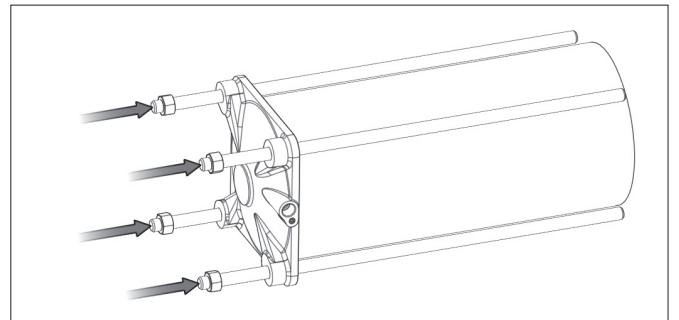

8.2 PISTON ASSEMBLY

1. Clean the piston. Apply Neles™ grease on rubber parts.
2. Place lip seal (16) and buffer cap (10) on its groove.

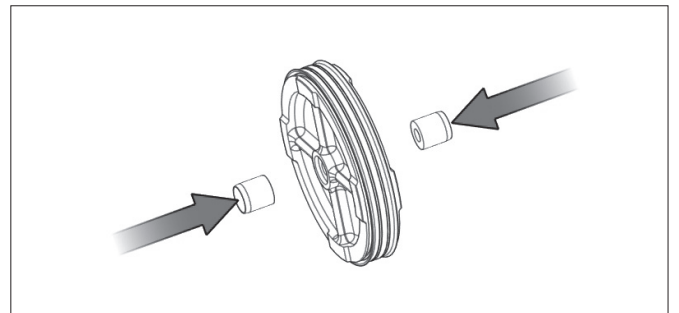

3. Apply drop of 7649 primer (dryer) on internal threads of piston rod. Wait for a minute and again apply a drop of 242 loctite on same threads. Now tighten the piston rod (5) with the help of SHC screw (8) by using washer (13).

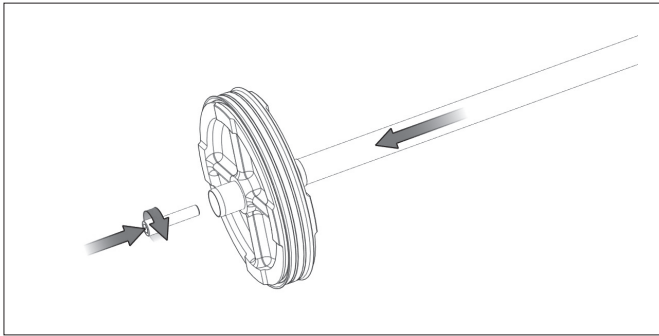

4. Insert this piston rod assembly carefully into the tube (3).

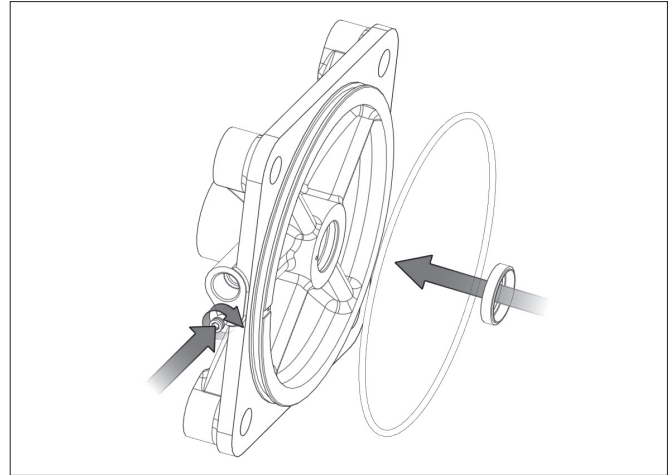
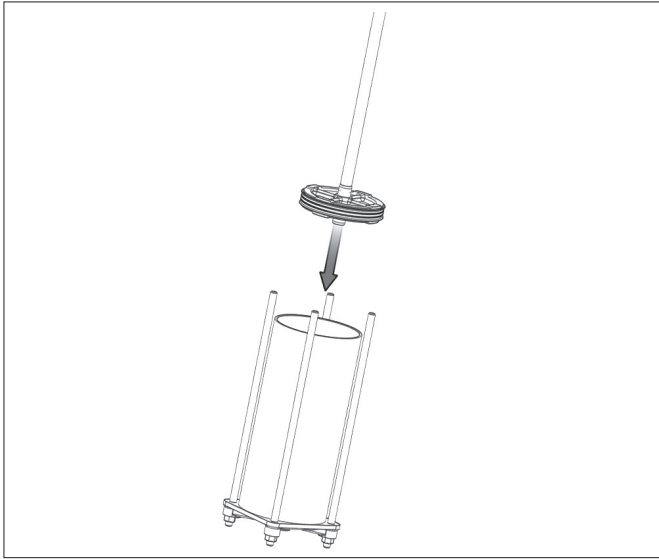

4. Assembled the front cover (1) on the tube (3), fasten the cylinder cover nut (9) and engage the lock nut (7).

8.3 FRONT COVER ASSEMBLY

1. Clean it with liquid soap solution. After drying apply Neles™ grease rubber parts.
2. Place rod seal (14) on its groove.

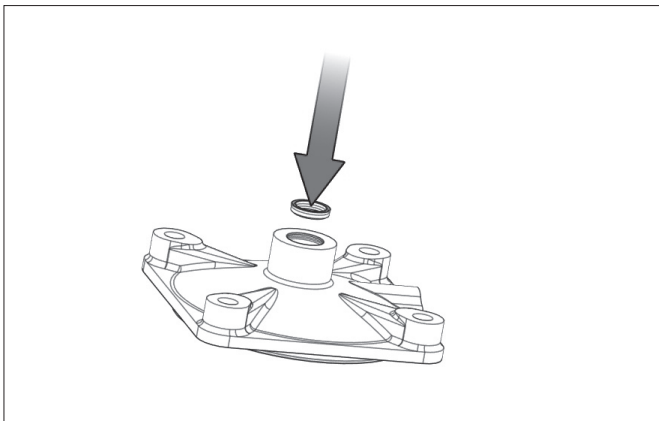

3. Place Cushioning seal (15) and o-ring (17) on its groove. Place o-ring (19) on cushioning screw (12), assemble the cushioning screw on rear cover (2).

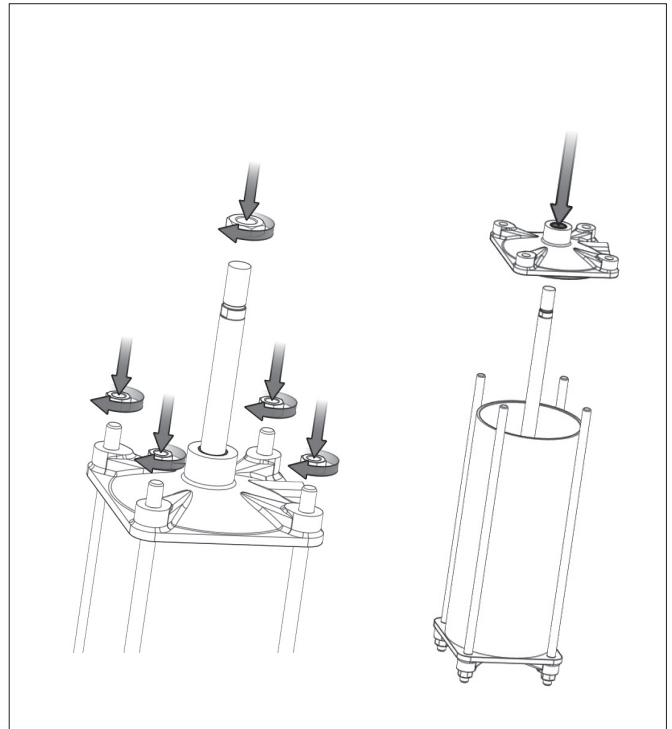

NOTE: Operate the cylinder assembly by hand. It should be free rotating piston rod & operating in and out.

9. EXPLODED VIEW

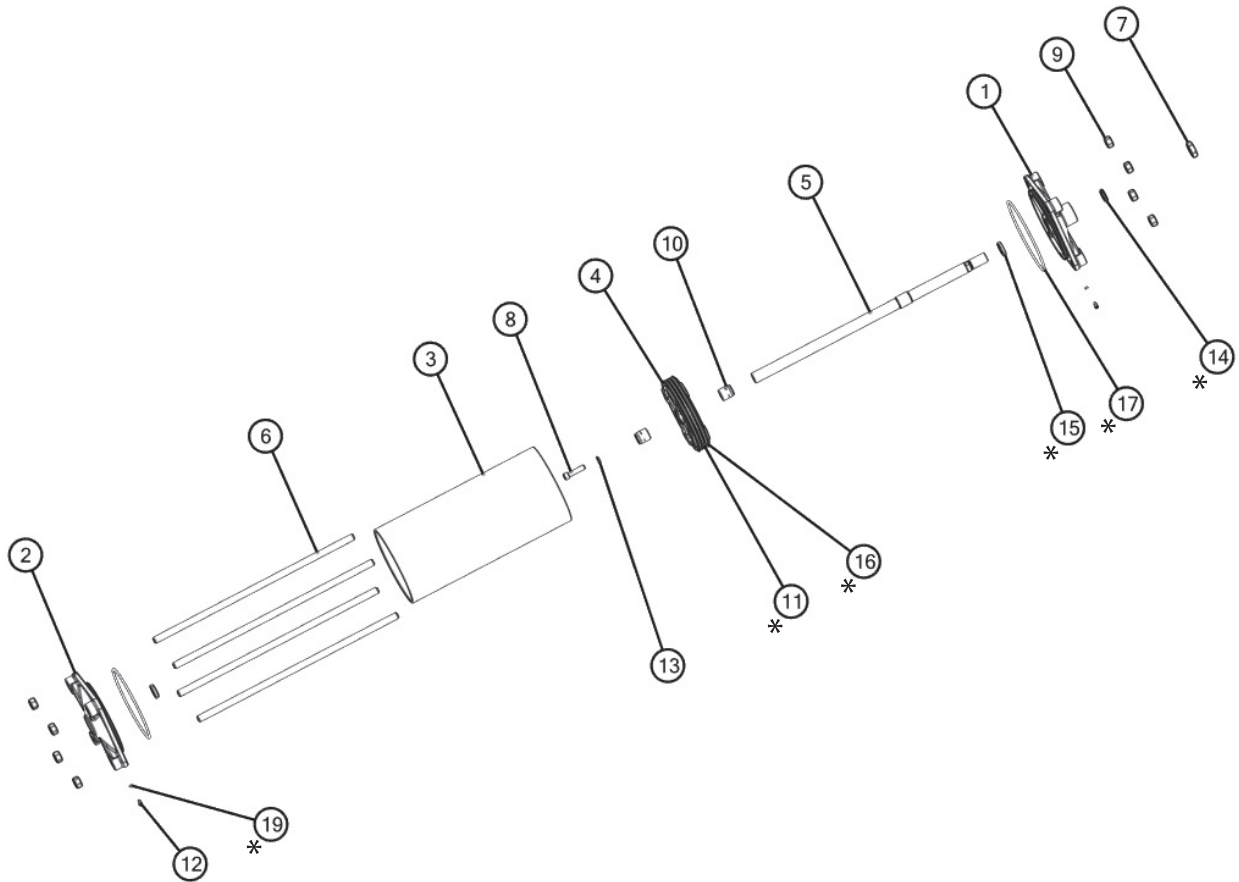

PART LIST		
Sr.No	Name	Quantity
1	FRONT COVER	1
2	REAR COVER	1
3	CYLINDER TUBE	1
4	PISTON	1
5	PISTON ROD	1
6	TIE ROD	4
7	NUT	1
8	SHC SCREW	1
9	NUT	8
10	BUFFER CAP	2
11*	PISTON STRIP	1
12	CUSHIONING PLUG	2
13	WASHER	1
14*	ROD SEAL	1
15*	CUSHIONING SEAL	2
16*	SEALS	2
17*	SEALS	2
19*	O-RING	2

NOTE: 1. * MARKED COMPONENTS ARE THE PARTS OF THE SEAL KIT.

10. PACKAGING & STORE

1. When not in use, CYLINDER ASSEMBLY should be kept in a sealed plastic bag in a cardboard box to prevent moisture or dust from contacting product.
2. CYLINDER ASSEMBLY should be stored in a dry place free from water and dust.
3. Store at temperature between 40°F and 120°F (4°C and 49°C).
4. Locate in an area to avoid damage by impact.

11. ASSISTANCE

For technical questions or assistance, contact any authorized distributor of Valmet Flow Control INDIA PVT.

Valmet Flow Control Oy

Vanha Porvoontie 229, 01380 Vantaa, Finland.

flowcontrol@valmet.com

Tel. +358 10 417 5000.

www.valmet.com/flowcontrol

Subject to change without prior notice.

Neles, Neles Easyflow, Jamesbury, Stonel, Valvcon and Flowrox, and certain other trademarks, are either registered trademarks or trademarks of Valmet Oyj or its subsidiaries in the United States and/or in other countries.

