

High performance Jamesbury™ Wafer-Sphere™ butterfly valves Series 800, Model D

Jamesbury™ Wafer-Sphere Model D is a soft seated double eccentric high-performance butterfly valve that provides long-lasting tight shutoff capability, excellent flow characteristics and long service life.

Due to a number of special constructions, developed from the versatile Wafer-Sphere design, these valves offer a powerful tool for standardization and are truly high performance valves.

The Wafer-Sphere high-performance butterfly valve is available in a range of materials and seat combinations suitable for service in a wide variety of applications including NACE MR0103 & MR0175. Also available are valves specifically prepared for chlorine, oxygen and high-vacuum applications.



Features

Offering

The following designs are available in sizes 3”–12” (DN 80–300), excluding 5” (DN125)

Body type	Wafer	Lugged	Double flanged
Design	API 609 ASME B16.34 EN 593	API 609 ASME B16.34 EN 593	API 609 ASME B16.34 EN 593
Pressure class	ASME Class 150 & 300 PN 10-40	ASME Class 150 & 300 PN 10-40	ASME Class 150 & 300 PN 10-40
Face to face	API 609 Cat B EN 558 Part 1, Table 5 Basic Series 16, 20 & 25	API 609 Cat B EN 558 Part 1, Table 5 Basic Series 16, 20 & 25	API 609 Cat B Short Pattern EN 558 Part 1, Table 5 Basic Series 13 ISO 5752 Series 13
Flange connection/ Drilling	ASME B16.5 EN 1092-1	ASME B16.5 EN 1092-1	ASME B16.5 EN 1092-1
Temperature range		-46 °C to 260 °C (-50 °F to 500 °F)	

Modularity

- Interchangeable modules ensure faster deliveries for a wide range of applications
- One piece drive thru shaft and high flow(one piece drive shaft with lower trunnion) options available
- Live-loaded packing as standard to minimize the product loss and emission.
- Same internal components regardless of body design results in similar flow characteristics and high flow capacity
- Same body independent of soft or metal seat

Performance

- Cost effective solution for reliable control and on/off performance.
- Heavy-duty stem and bearings arrangement extend service life and are insensitive to thermal cycles.
- Reliable against changing operational conditions i.e. flow vibration and temperature/ pressure changes.

- Anti-blow out design (Positive Shaft Retention) valves are equipped with retainer plates on top of the gland to contain the shaft within the body if for any reason the shaft should break within the valve.
- Easy Seat Maintenance: Interchangeable seat can be replaced without disassembling the disc and shaft. Seat replacement does not require any adjustment or special tools.
- Lugged and double flange style valves are suitable for bidirectional dead-end service at the full pressure temperature rating as standard.
- Lifting holes for valves weighting over 20 kg
- PTFE V-ring or graphite packing for a wide range of applications.

Field-proven single-piece flexible seat design

- Xtreme™ seat provides longer life, expanded performance boundaries, and greater value
- Lip-seal shape of seat design compensates for temperature and pressure changes
- Bi-directional long last tightness is maintained even in high cycle rate services.
- Low friction and lasting wear resistance.
- Longer service life with less maintenance
- No secondary components required to maintain tightness
- Sealing element protected in the seat pocket for lowest wear & tear

Offset shaft and eccentric disc

- No seat/disc contact in the open or intermediate position
- Eliminates wear points at top and bottom of seats for high cycle life

Approvals/Reliability/Safety

- ISO 15848
- Group II Category 2 according to directive 2014/34/EU (ATEX II 3 G c)
- NACE MR0103 & MR0175

CE marked versions available

- CE marked and documentation conform with the European Pressure Equipment Directive (PED) 2014/68/ and are available in standard designs. Operating torques, construction options and valve dimensions are exactly the same as the non-CE offering

Excellent for both on-off and control applications

- Inherent flow characteristic is modified equal percentage
- Wide rangeability
- Tight shut-off even in control applications
- Good controllability via smoothly rising installed characteristic curve at both very small openings and nearly fully open positions
- Good dynamic stability in both flow directions

Single-source responsibility

- Purchase valves, actuators, and accessories, completely mounted from one source
- Available with electric, manual gear, and pneumatic double acting or spring return actuators and a variety of accessories including limit switches, solenoids, and positioners
- OEM service available through world-wide service centers

Valve construction

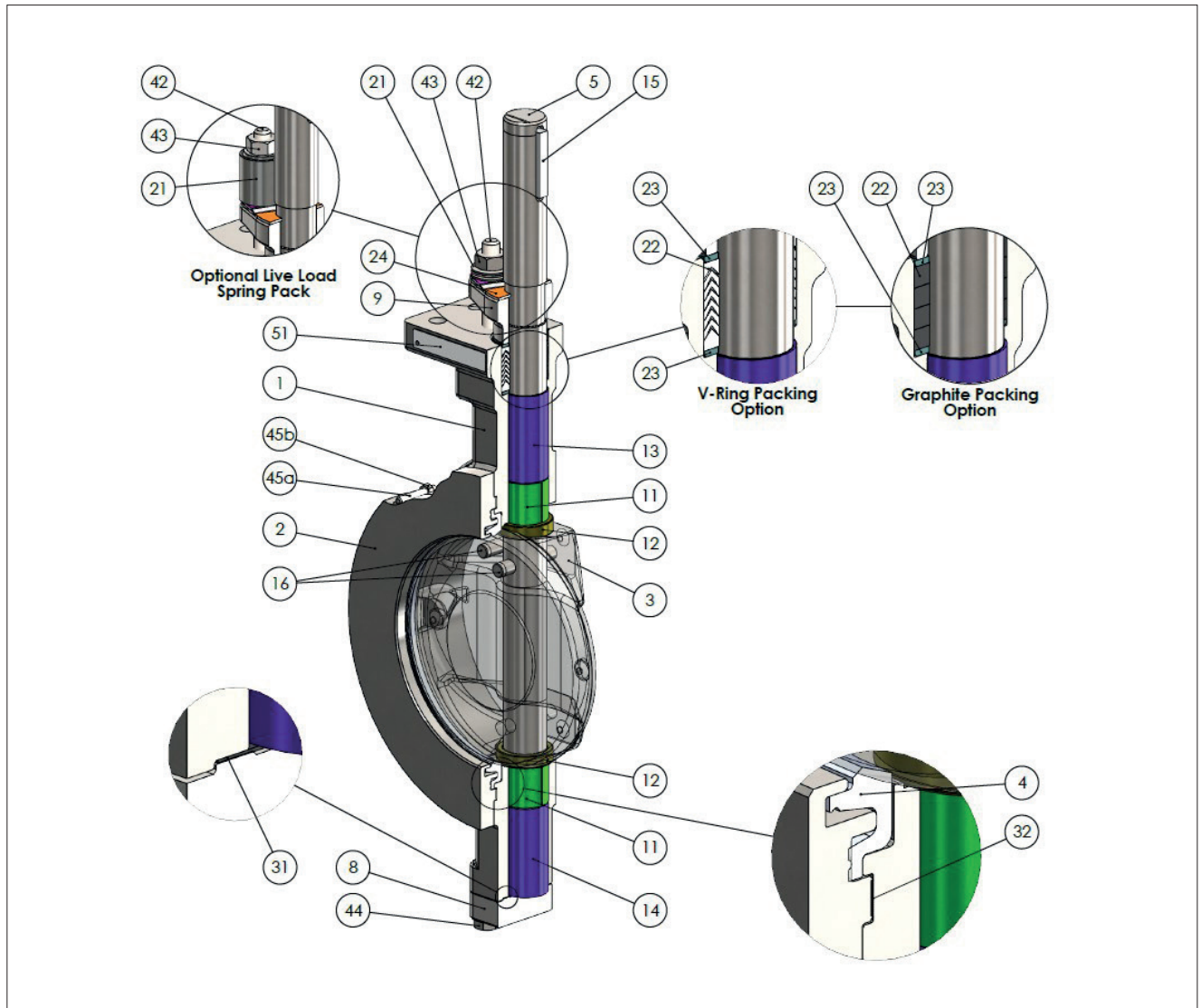

Part no.	Description	Material
1	BODY	ASTM A216 gr. WCB/1.0619 A351 gr. CF8M/1.4408
2	CLAMP RING	A351 gr. CF8M/1.4408
3	DISC	ASTM A351 gr. CF8M
4	SEAT	Xtreme, PTFE
5	SHAFT	A564 gr. 630 H1150D ASTM A479 gr. 316
8	BLIND FLANGE	A351 gr. CF8M/1.4408
9	GLAND	A351 gr. CF8M/1.4408
11	BEARING	625+PVDC 316L+RPTFE
12	THRUST BEARING	ASTM A269 gr.316+HCr
13	BEARING SPACER	AISI 316
14	BEARING SPACER	AISI 316
15	KEY	EN 10088-1.4460

Part no.	Description	Material
16	PIN	A564 gr. 630 H1150D ASTM A479 gr. 316
21	DISC SPRING SET	AISI 303//50CrV4+ENP AISI 304
22	PACKING RING SET	GRAPHITE PTFE
23	ANTI EXTRUSION RING	AISI 316
24	RETAINER	AISI 316
31	GASKET	GRAPHITE
32	BODY GASKET	GRAPHITE
42	STUD	ASTM A193 gr. B8M cl. 2
43	HEXAGON NUT	ASTM A194 gr. 8M
44	HEXAGON SCREW	ASTM A193 gr. B8M cl. 2
45a	STUD	ASTM A193 gr. B8M cl. 2
45b	HEXAGON NUT	ASTM A194 gr. 8M
51	IDENTIFICATION PLATE	AISI 316

Technical specifications

Product type

- Double flange body design
- Wafer type body design
- Lug type body design

Size range

- NPS 3"-12" (excl. 5")
- DN 80-300 (excl. DN125)

Pressure classes

- ASME150 & ASME300, PN 10 - 40

Temperature range

- -46 °C to 260 °C (-50 °F to 500 °F)

Design standard

In accordance with ASME B16.34, API 609 cat B, EN 593

Standard materials

Body:	EN 10213-1.0619 / ASTM A 216 gr. WCB EN 10213-1.4408 / ASTM A 351 gr. CF8M
Disc:	EN 10088-1.4401 / ASTM A 182 gr. F316 EN 10213-1.4408 / ASTM A 351 gr. CF8M

Clamp ring:	EN 10213-1.4408 / ASTM A 351 gr. CF8M
Shafts and pins:	AISI 316 / ASTM A 546 gr. 630 (17-4PH)
Seat ring:	Xtreme, PTFE
Bearings:	AISI 316 + PTFE

Material and test certifications

EN 10204-3.1B material certificates for body, clamp ring, gland and blind flange. Disc and shaft certification on request. Tightness test certificate.

Approvals

ISO 15848-1 fugitive emissions

Tightness (Bi-directional)

ANSI/FCI 70-2 establishes a series of six leakage classes for control valves and defines the test procedure. Class VI allows the least leakage and is measured in bubbles per minute. The series 815 & 830 high performance butterfly valves are bubble-tight, MSS-SP61, which exceeds Class VI requirements.

Optimal leakage tests per ISO 5208 & API 598 can be conducted per request.

Valve body ratings

The tables below are maximum working pressure ratings of the **valve body only**. The seat ratings and/or shaft material determine the practical pressure limitations according to actual service conditions. Test pressures are for hydrostatic test with disc open.

Pressure/temperature ratings for valve body, WCB

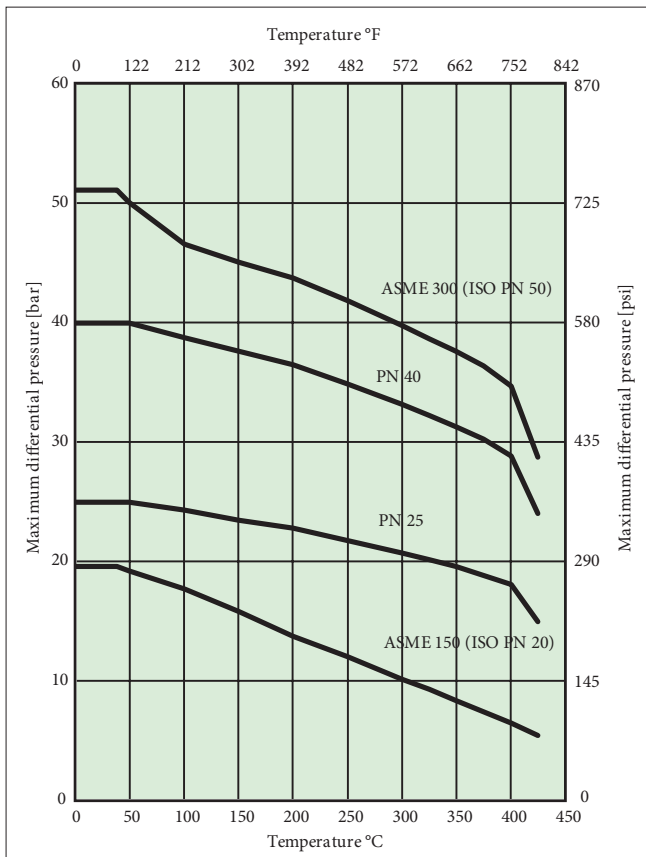

Pressure/temperature ratings for valve body, CF8M

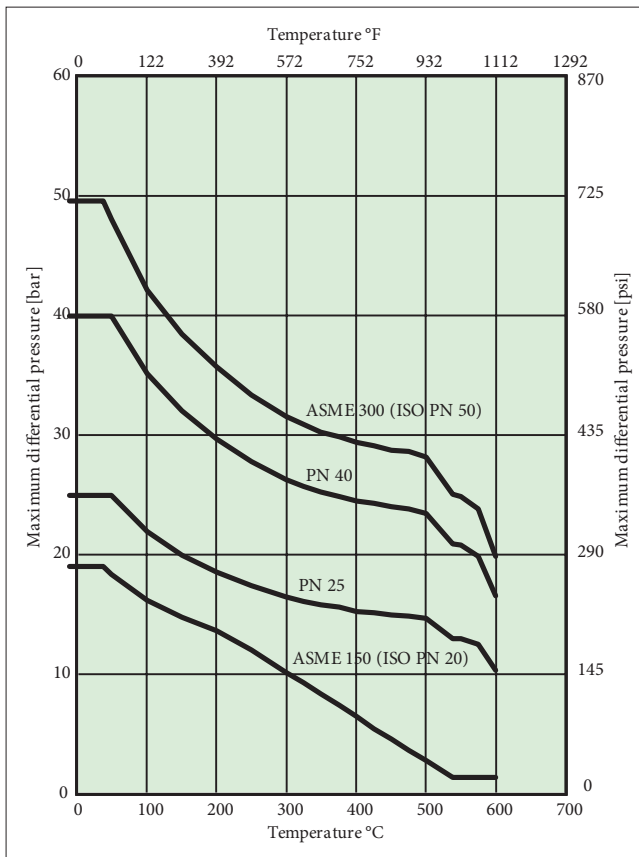

Seat ratings

These ratings are a conservative guide for general service. Previous experience in a process or new developments and alternative seat materials may permit applications at ratings above those shown. Please consult our home office for specific recommendations.

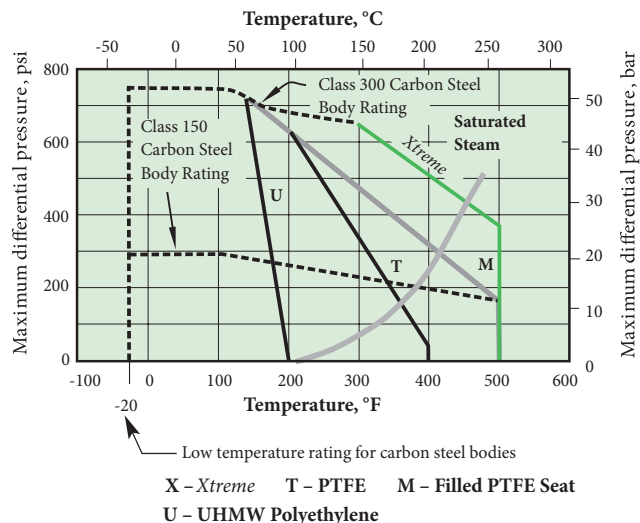

Flow data

The tables below provide flow coefficients for Series 800 butterfly valves covered in this bulletin. The Cv values represent the number of gallons per minute of +60°F water that flows through a fully open valve at a pressure drop of 1 psi. The metric equivalent Kv is the flow of water at 16°C through the valve in cubic meters per hour at a pressure drop of 1kg/cm2. To convert Cv to Kv multiply by 0.8569.

Inch	DN	Design style	Cv	
			ASME 150	ASME 300
3	80	Through shaft	220	220
4	100	Through shaft	357	357
6	150	Through shaft	1240	1020
8	200	Through shaft	1990	1670
10	250	Through shaft	3470	3150
12	300	Through shaft	5320	4050

Inch	DN	Design style	Cv	
			ASME 150	ASME 300
3	80	Drive shaft + trunnion	247	247
4	100	Drive shaft + trunnion	482	482
6	150	Drive shaft + trunnion	1630	1260
8	200	Drive shaft + trunnion	2400	1810
10	250	Drive shaft + trunnion	4460	3600
12	300	Drive shaft + trunnion	6820	4670

Seat designs

Xtreme performance and value

Xtreme seats provide longer life, expanded performance boundaries, and the greatest possible value. Xtreme is a unique material that resulted from a technological breakthrough in our polymer research lab. The material is a fluoropolymer-based blend proprietary to Jamesbury that provides superior quarter-turn performance.

Standard seats

Wafer-Sphere standard seat design, constructed of PTFE, Filled PTFE, or UHMW Polyethylene, utilizes a flexible lip, which, when distorted, will always attempt to return to its original shape and maintain a seal against the disc regardless of flow direction.

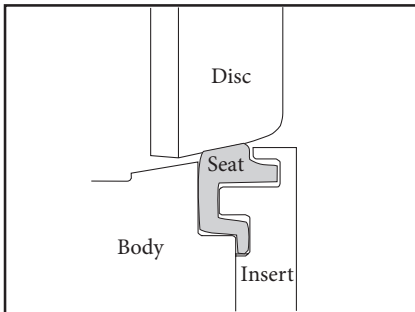

When the valve is shut, the disc slightly deflects the seat. This slight deflection “energizes” the seat. While energized, the sealing surface of the seat is constantly pushing against the edge of the disc.

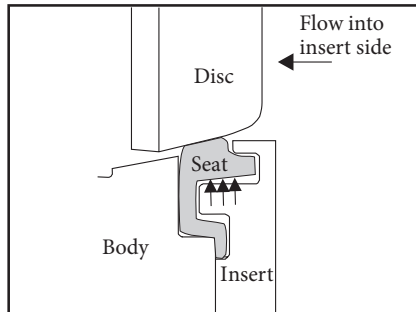

When pressure is on the insert side, pressure is applied under the seat lip. This further amplifies the sealing force between the disc and the seat.

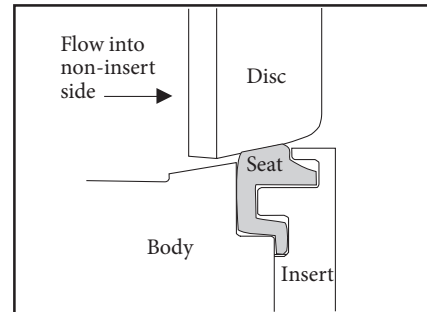

When pressure is on the non-insert side, the disc moves into the seat. Due to the spherical profile of the disc, the more the disc moves into the seat, the tighter the shut-off. Excessive movement of the seat is limited by the flexible lip which contacts the bottom of the groove in the insert ring.

Valve torque data

Torque – Series 815, 810 and 816

Valve size		Shaft downstream; T & X seats					
Inches	DN	Shut-off differential pressure					
		Nm @ 6.9 bar	Ft•lbs @ 100 psi	Nm @ 13.8 bar	Ft•lbs @ 200 psi	Nm @ 19.7 bar	Ft•lbs @ 285 psi
3	80	34	25	37	27	39	29
4	100	47	35	53	39	58	43
6	150	97	72	113	83	126	93
8	200	164	121	193	142	217	160
10	250	222	163	274	202	318	234
12	300	290	214	390	287	475	350

Torque – Series 830, 825 and 840

Valve size		Shaft downstream; T & X seats											
Inches	DN	Shut-off differential pressure											
		Nm @ 20.7 bar	Ft•lbs @ 300 psi	Nm @ 27.6 bar	Ft•lbs @ 400 psi	Nm @ 34.5 bar	Ft•lbs @ 500 psi	Nm @ 41.4 bar	Ft•lbs @ 600 psi	Nm @ 48.3 bar	Ft•lbs @ 700 psi	Nm @ 51 bar	Ft•lbs @ 740 psi
3	80	42	31	46	34	51	38	55	41	60	44	62	45
4	100	70	52	79	58	88	65	97	72	106	78	110	81
6	150	161	119	188	138	214	158	241	178	267	197	278	205
8	200	313	231	368	271	422	312	477	352	532	392	554	408
10	250	480	354	572	422	664	490	756	557	848	625	885	652
12	300	667	492	790	582	913	673	1035	764	1158	854	1207	890

Dimensions

Double flanged design

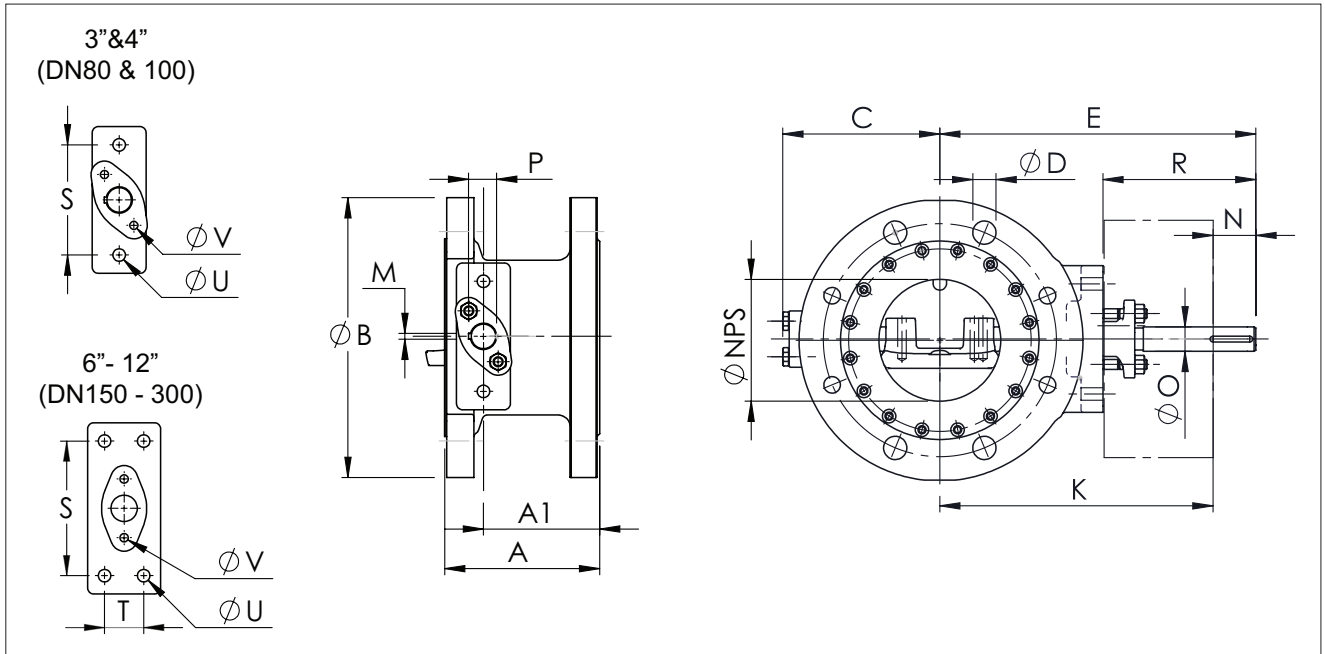

Double flange (ASME 150)

DN	NPS	Dimensions (mm)																	Weight (kg)
		A (API/Series 13)	A1	ØB	C	D	E	K	M	N	O	P	R	S	T	U	V		
80	3	114	86	190	115	19	226	201	4.8	25	15	17.0	105	70	-	M10	M8	10	
100	4	127	95	230	135	19	258	223	4.8	35	20	22.2	125	90	-	M12	M8	18	
150	6	140	107	280	165	22	277	242	4.8	35	20	22.2	125	110	32	M12	M8	26	
200	8	152	115	345	195	22	323	277	6.4	46	25	27.8	136	110	32	M12	M10	43	
250	10	165	125	405	230	25	393	342	6.4	51	30	32.9	161	130	32	M12	M12	61	
300	12	178	134	485	265	25	428	370	9.5	58	35	39.1	168	130	32	M12	M12	94	

Double flange (PN10-16)

DN	NPS	Dimensions (mm)																	Weight (kg)	
		A (API/Series 13)	A1	ØB (PN10)	ØB (PN16)	C	D (PN10)	D (PN16)	E	K	M	N	O	P	R	S	T	U		V
80	3	114	86	200	200	115	18	18	226	201	4.8	25	15	17.0	105	70	-	M10	M8	12
100	4	127	95	220	220	135	18	18	258	223	4.8	35	20	22.2	125	90	-	M12	M8	16
150	6	140	107	285	285	165	22	22	277	242	4.8	35	20	22.2	125	110	32	M12	M8	25
200	8	152	115	340	340	195	22	22	323	277	6.4	46	25	27.8	136	110	32	M12	M10	39
250	10	165	125	395	405	230	22	26	393	342	6.4	51	30	32.9	161	130	32	M12	M12	57
300	12	178	134	445	460	265	22	26	428	370	9.5	58	35	39.1	168	130	32	M12	M12	81

Double flange (ASME 300)

DN	NPS	Dimensions (mm)																	Weight (kg)
		A (API/Series 13)	A1	ØB	C	D	E	K	M	N	O	P	R	S	T	U	V		
80	3	114	86	210	115	22	226	201	4.8	25	15	17.0	105	70	-	M10	M8	15	
100	4	127	95	255	135	22	258	223	4.8	35	20	22.2	125	90	-	M12	M8	25	
150	6	140	104	320	185	22	321	275	6.4	46	25	27.8	136	110	32	M12	M10	47	
200	8	152	108	380	220	25	381	323	9.5	58	35	39.1	168	130	32	M12	M12	71	
250	10	165	117	445	260	29	442	374	9.5	68	40	44.2	188	160	40	M16	M12	108	
300	12	178	124	520	305	32	535	445	12.7	90	50	55.5	230	160	55	M20	M16	169	

Double flange (PN25-40)

DN	NPS	Dimensions (mm)																	Weight (kg)	
		A (API/Series 13)	A1	ØB (PN25)	ØB (PN40)	C	D (PN25)	D (PN40)	E	K	M	N	O	P	R	S	T	U		V
80	3	114	86	200	200	115	18	18	226	201	4.8	25	15	17.0	105	70	-	M10	M8	13
100	4	127	95	235	235	135	22	22	258	223	4.8	35	20	22.2	125	90	-	M12	M8	20
150	6	140	104	300	300	185	26	26	321	275	6.4	46	25	27.8	136	110	32	M12	M10	37
200	8	152	108	360	375	220	26	30	381	323	9.5	58	35	39.1	168	130	32	M12	M12	63
250	10	165	117	425	450	260	30	33	442	374	9.5	68	40	44.2	188	160	40	M16	M12	101
300	12	178	124	485	515	305	30	33	535	445	12.7	90	50	55.5	230	160	55	M20	M16	155

Wafer design

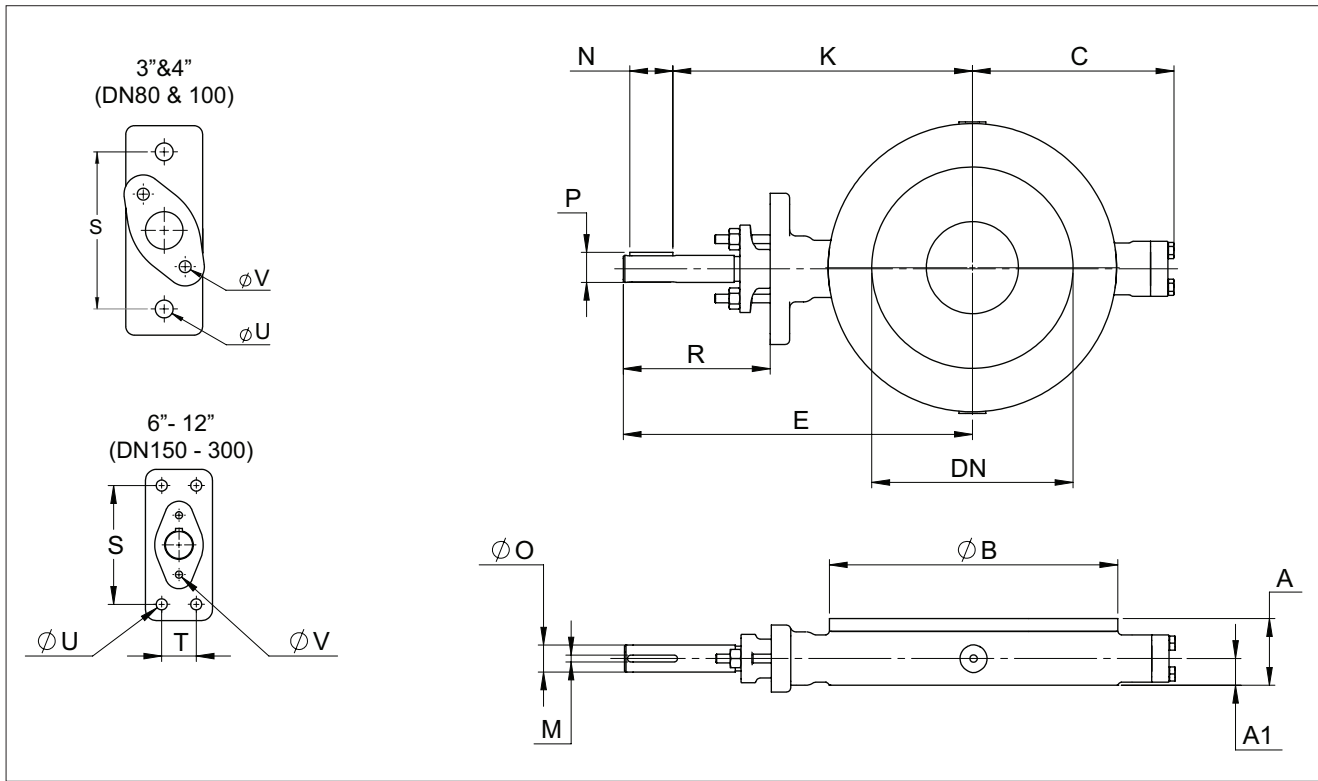

Wafer (ASME 150, PN10-16)

DN	NPS	Dimensions (mm)																Weight (kg)
		A (API)	A (Series 25)	A1	ϕB	C	E	K	M	N	O	P	R	S	T	U	V	
80	3	48	49	20	131	115	226	201	4.8	25	15	17.0	105	70	-	M10	M8	6
100	4	54	56	22	156	135	258	223	4.8	35	20	22.2	125	90	-	M12	M8	8
150	6	57	70	24	217	165	277	242	4.8	35	20	22.2	125	110	32	M12	M8	15
200	8	64	71	25	267	195	323	277	6.4	46	25	27.8	136	110	32	M12	M10	25
250	10	71	76	30	328	230	393	342	6.4	51	30	32.9	161	130	32	M12	M12	44
300	12	81	83	37	375	265	428	370	9.5	58	35	39.1	168	130	32	M12	M12	56

Wafer (ASME 300, PN25-40)

DN	NPS	Dimensions (mm)																Weight (kg)
		A (API)	A (Series 16)	A1	ϕB	C	E	K	M	N	O	P	R	S	T	U	V	
80	3	48	64	20	131	115	226	201	4.8	25	15	17.0	105	70	-	M10	M8	6
100	4	54	64	22	156	135	258	223	4.8	35	20	22.2	125	90	-	M12	M8	8
150	6	59	76	25	217	185	321	275	6.4	46	25	27.8	136	110	32	M12	M10	19
200	8	73	89	32	280	220	381	323	9.5	58	35	39.1	168	130	32	M12	M12	35
250	10	83	114	38	340	260	442	374	9.5	68	40	44.2	188	160	40	M16	M12	60
300	12	92	114	41	400	305	535	445	12.7	90	50	55.5	230	160	55	M20	M16	91

Lug design

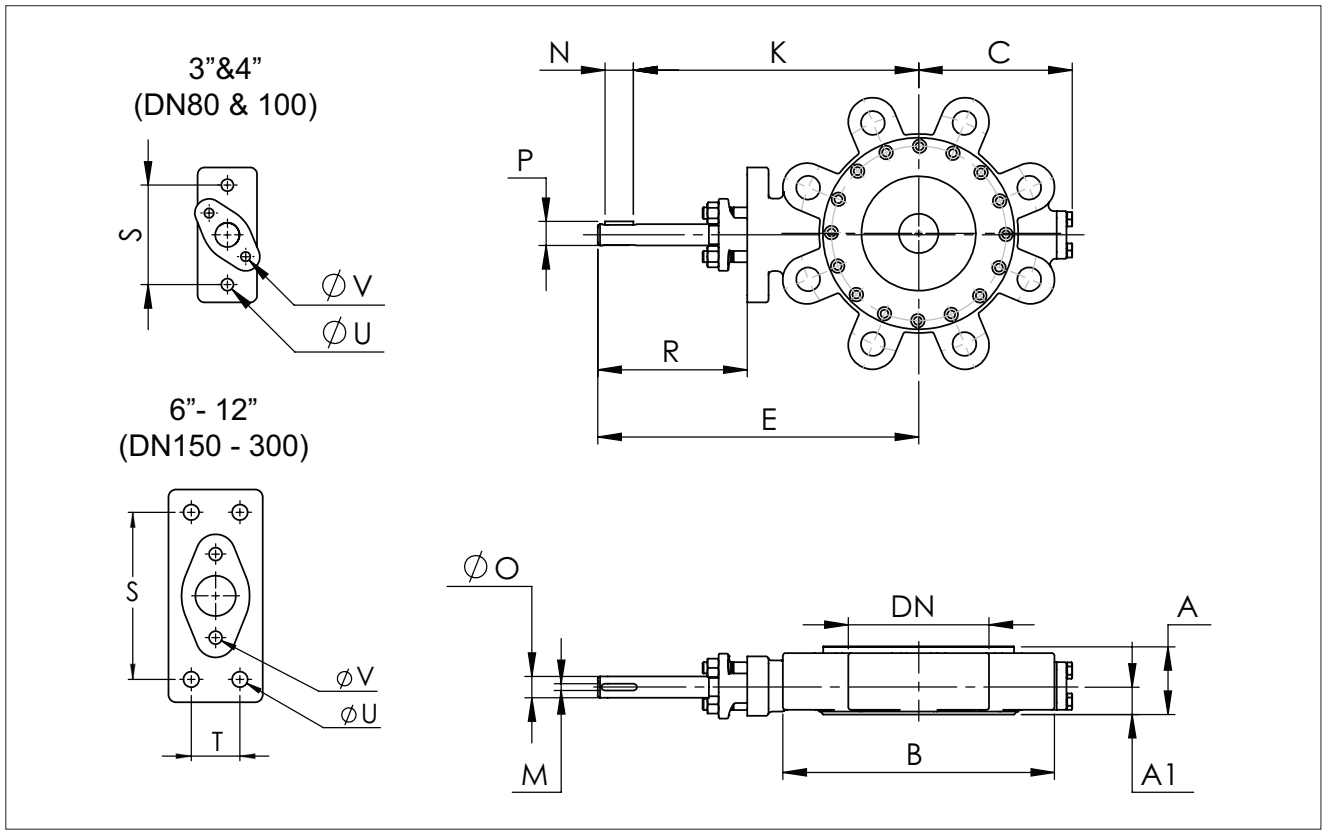

Lug (ASME 150, PN10-16)

DN	NPS	Dimensions (mm)																Weight (kg)
		A (API)	A (Series 25)	A1	ØB	C	E	K	M	N	O	P	R	S	T	U	V	
80	3	48	49	20	180	115	226	201	4.8	25	15	17.0	105	70	-	M10	M8	10
100	4	54	56	22	240	135	258	223	4.8	35	20	22.2	125	90	-	M12	M8	14
150	6	57	70	24	280	165	277	242	4.8	35	20	22.2	125	110	32	M12	M8	19
200	8	64	71	25	335	195	323	277	6.4	46	25	27.8	136	110	32	M12	M10	34
250	10	71	76	30	405	230	393	342	6.4	51	30	32.9	161	130	32	M12	M12	53
300	12	81	83	37	475	265	428	370	9.5	58	35	39.1	168	130	32	M12	M12	70

Lug (ASME 300, PN25-40)

DN	NPS	Dimensions (mm)																Weight (kg)
		A (API)	A (Series 16)	A1	ØB	C	E	K	M	N	O	P	R	S	T	U	V	
80	3	48	64	20	205	115	226	201	4.8	25	15	17.0	105	70	-	M10	M8	10
100	4	54	64	22	240	135	258	223	4.8	35	20	22.2	125	90	-	M12	M8	14
150	6	59	76	25	320	185	321	275	6.4	46	25	27.8	136	110	32	M12	M10	31
200	8	73	89	31	380	220	381	323	9.5	58	35	39.1	168	130	32	M12	M12	46
250	10	83	114	37	445	260	442	374	9.5	68	40	44.2	188	160	40	M16	M12	84
300	12	92	114	40	505	305	535	445	12.7	90	50	55.5	230	160	55	M20	M16	113

Dimensions for valves with square shaft connection

Same dimensions apply for all body types. Other dimensions as in above tables

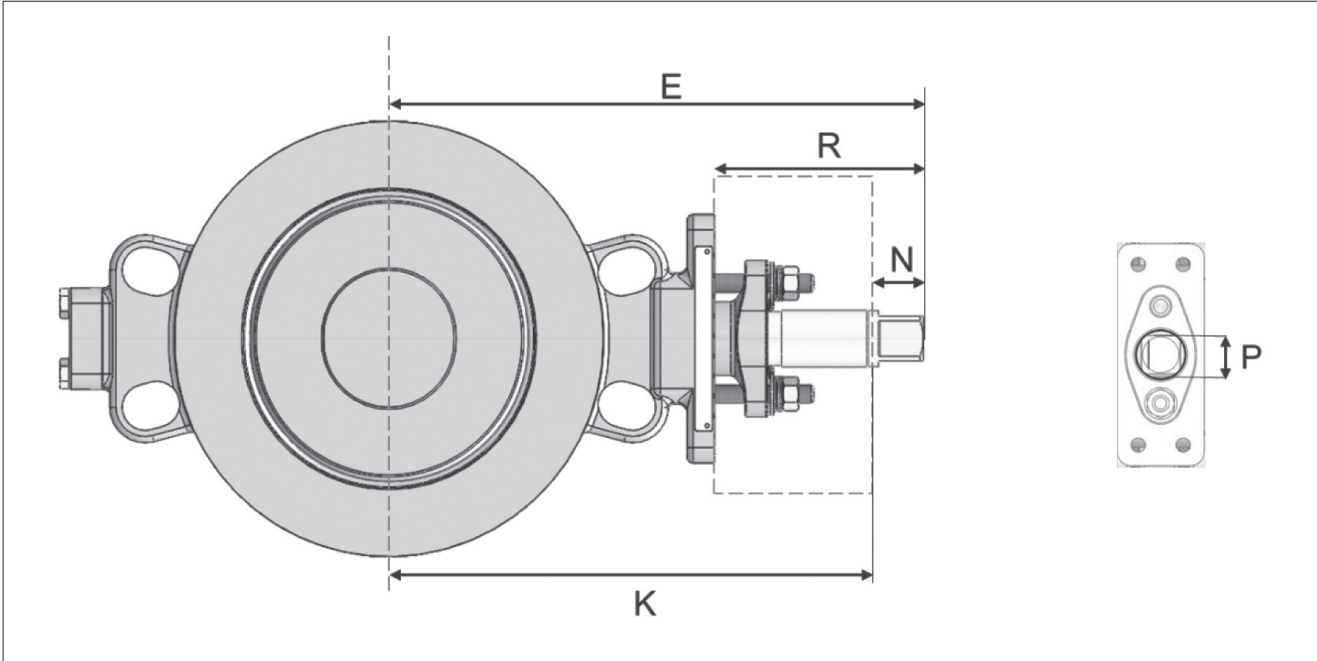

ASME 150, PN10-16

Size		E	K	N	P	R
DN	Inch					
80	3	213	201	12	11	92
100	4	239	223	16	14	106
150	6	258	242	16	14	106
200	8	298	277	21	19	111
250	10	366	342	24	22	134
300	12	399	370	29	27	139

ASME 300, PN25-40

Size		E	K	N	P	R
DN	Inch					
80	3	213	201	12	11	92
100	4	239	223	16	14	106
150	6	296	275	21	19	111
200	8	352	323	29	27	139
250	10	406	374	32	30	152
300	12	483	445	38	36	178

Type code

1.	2.	3.	4.	5.	6.	7.	8.	9.	10.	11.	12.
6	-	8	15	W	-	19	22	36	XT	D	-

1. sign	VALVE SIZE (inches / mm)
ASME	3, 4, 6, 8, 10, 12
PN	80, 100, 150, 200, 250, 300

*)After size code leave one space before construction code.

2. sign	VALVE CONSTRUCTION
-	Standard

3. sign	VALVE SERIES
8	Wafer Sphere butterfly valve

4. sign	PRESSURE CLASS & FACE TO FACE
15	ASME Class 150, API 609 face to face
18	ASME Class 150 w/CE Marking and Documentation, API 609 face to face
30	ASME Class 300, API 609 face to face
38	ASME Class 300 w/CE Marking and Documentation, API 609 face to face
10	PN10, EN 558-part 1, table 5 / basic series 25 (DIN 3202-K2) face to face
16	PN16, EN 558-part 1, table 5 / basic series 25 (DIN 3202-K2) face to face
25	PN25, EN 558-part 1, table 5 / basic series 16 (DIN 3202-K3) face to face
40	PN40, EN 558-part 1, table 5 / basic series 16 (DIN 3202-K3) face to face

5. sign	BODY STYLE
W	Wafer
L	Lugged
F	Double flanged

6. sign	CONSTRUCTION
-	STANDARD (max +260 °C) Bearings 316 + PTFE-based coating Body and blind flange gaskets graphite Fulfills NACE MR0175 for Wafer (sign 5 W) Anti-static device (ATEX II 3 G c)
O	OXYGEN SERVICE (max. +140°C) • BAM/WHA approved soft parts • T = -30°C...+140°C • Max pressure = 26 bar • Oxygen cleaning acc. to Neles internal procedure FC-M-1360-En Note! No carbon steel body material allowed. Note! Only "O" construction available for oxygen flow media. Not to be used with other flow medias.
B	BEARING PROTECTION PTFE bearing protection Otherwise as standard
N	NACE Fulfills NACE MR0175 for Lug and Double flange (sign 5 L and F) NACE compliant clamp ring bolting Otherwise as Standard

7. sign	SHAFT DESIGN
19	Through shaft, keyway shaft connection, compatible with harmonized Neles bracket
24	Drive shaft + trunnion, square shaft connection, compatible with harmonized Neles bracket
29	High Flow (Drive shaft + trunnion, keyway shaft connection, compatible with harmonized Neles bracket.)

8. & 9. sign	BODY MATERIAL	DISC ANS SHAFT
2236 ³⁾	WCB (1.0619)	CF8M (1.4408) / AISI 316, strain hardened
22HB ^{1,3)}	WCB (1.0619)	CF8M (1.4408) / Gr. 630 (17-4PH)
28HB	ASTM A352 gr. LCC	CF8M (1.4408) / Gr. 630 (17-4PH)
25HB	ASTM A352 gr. LCB	CF8M (1.4408) / Gr. 630 (17-4PH)
3400	ASTM A351 gr. CF8 / AISI 304	ASTM A351 gr. CF8 (AISI 304) / AISI 316, strain hardened
34HB	ASTM A351 gr. CF8 / AISI 304	CF8M (1.4408) / Gr. 630 (17-4PH)
3600	CF8M (1.4408)	CF8M (1.4408) / AISI 316, strain hardened
36HB ¹⁾	CF8M (1.4408)	CF8M (1.4408) / Gr. 630 (17-4PH)
3700	ASTM A351 gr. CG8M / AISI 317	ASTM A351 gr. CG8M (AISI 317) / AISI 316, strain hardened
37HB ¹⁾	ASTM A351 gr. CG8M / AISI 317	CF8M (1.4408) / Gr. 630 (17-4PH)
3900	ASTM A351 gr. CF3 / AISI 304L	ASTM A351 gr. CF3 (AISI 304L) / AISI 316, strain hardened
39HB	ASTM A351 gr. CF3 / AISI 304L	CF8M (1.4408) / Gr. 630 (17-4PH)
6E00	ASTM A351 gr. CF3M / AISI 316L	ASTM A351 gr. CF3M (AISI 316L) / AISI 316, strain hardened
6EHB	ASTM A351 gr. CF3M / AISI 316L	CF8M (1.4408) / Gr. 630 (17-4PH)
7100 ^{1,2)}	ASTM A494 gr. M-35-1 (Monel 400)	ASTM A494 gr. M-35-1 (Monel 400)
4J00	ASTM A995 gr. 4A / EN 10213 - 1.4517	ASTM A995 gr. 4A / EN 10213 - 1.4517/ UNS 32750
4L00	ASTM A995 gr. 5A / EN 10213 - 1.4469	ASTM A995 gr. 5A / EN 10213 - 1.4469/ UNS 32750

10. sign	SEAT AND SEAL COMBINATION	
	SEAT	SEAL
XT	Xtreme	Virgin PTFE V-ring set
XL	Xtreme	Graphite
TT	Virgin Teflon (PTFE)	Virgin PTFE V-ring set

11. sign	MODEL CODE
D	Mod D, modular butterfly valve platform

12. sign	MODIFIER CODE
-	Standard live loaded packing (ISO15848-1 certified)
QY	High performance live loaded (ISO15848-1 certified)

- 1 Material meets NACE MR0103 requirements for sour environments. For valves to be in full compliance with NACE MR0103, both the body (sign #8) and trim (sign #9) must meet the NACE MR0103 requirement.
- 2 Valves with the Disc & Shaft Material Code "00" (sign #9) meet the NACE MR0103 requirement for sour environments if the body code (sign #8) is 71.
- 3 Disc & Shaft Material Code "00" (sign #9) is not available with 22 body material.

Consult factory regarding other materials of construction that are not listed.

Valmet Flow Control Oy

Vanha Porvoontie 229, 01380 Vantaa, Finland.

Tel. +358 10 417 5000.

www.valmet.com/flowcontrol

Subject to change without prior notice.

Neles, Neles Easyflow, Jamesbury, Stonel, Valvcon and Flowrox, and certain other trademarks, are either registered trademarks or trademarks of Valmet Oyj or its subsidiaries in the United States and/or in other countries.

