

**Jamesbury™ Wafer-Sphere™
butterfly valve
model C cryogenic
class 150 & 300
3" - 30" (DN80 - 750)**

Installation, maintenance and
operating instructions



Table of contents

GENERAL	3	MANUAL HANDLES	12
Scope of the Manual	3	General	12
Offset Shaft Design	3	Change of Handle Quadrant	12
Positive Stop Feature	3	Setting Handle Stop	13
Actuation	3	ACTUATOR	13
Wafer Body Design	4	Actuator Mounting Instructions	14
Snap-in Inserts	4	Direct Drive Mounting	15
Valve Markings	4	REPAIR KITS	15
Safety Precautions	5	SERVICE / SPARE PART	15
Welding notes	5	ASSEMBLY AND PARTS LIST	16
TRANSPORTATION AND STORAGE	6	TYPE CODE	20
INSTALLATION	6	GENERAL SAFETY WARNINGS AND DISCLAIMERS	21
General	6	General safety warnings	21
Installing in the pipeline	6	General disclaimers	21
Valve Insulation	6		
Actuator	7		
Commissioning	7		
MAINTENANCE	7		
General	7		
Actuated Valve	8		
Valve Removal	8		
Composite Seat Replacement for 3"-12" (DN80-33) Valves	9		
Solid (PCTFE) Seat Replacement for 14" (DN350) and Larger Valves	9		
Shaft Seal Replacement	10		
Valve Disassembly	11		
Checking Parts	11		
Valve Assembly	11		
Testing the Valve	12		

READ THESE INSTRUCTIONS FIRST!

These instructions provide information about safe handling and operation of the valve.

If you require additional assistance, please contact the manufacturer or manufacturer's representative.

SAVE THESE INSTRUCTIONS!

Addresses and phone numbers are printed on the back cover.

INTRODUCTION

READ THESE INSTRUCTIONS FIRST!

These instructions provide information about safe handling and operation of the valve. If you require additional assistance, please contact the manufacturer or manufacturer's representative. Addresses and phone numbers are printed on the back cover.

See also www.valmet.com/flowcontrol/valves for the latest documentation.

SAVE THESE INSTRUCTIONS!

The following instructions should be thoroughly reviewed and understood prior to installing, operating or performing maintenance on this equipment. Throughout the text, safety and/or caution notes will appear and must be strictly adhered to, otherwise, serious injury or equipment malfunction could result.

Valmet has highly skilled personnel available for startup, maintenance and repair of our valves and component parts.

Arrangements for this service can be made through your local Valmet representative or sales department. When performing maintenance use only Valmet replacement parts. Parts are obtainable through your local representative or spare parts department.

When ordering parts, always include Model and Serial Number of the unit being repaired.

1. GENERAL

These installation and maintenance instructions apply to 3"-30" (DN80-750), pressure class 150 & 300 cryogenic Model C 800 series regardless of the type of material used. The 800 series valves are designed with built in versatility making them well-suited to handle a wide variety of process applications.

Recommended spare parts required for maintenance refer to sections 7 and 8. The model number, size, rating and serial number of the valve are shown on the identification tag located on the valve.

1.1 SCOPE OF THE MANUAL

This instruction manual contains important information regarding the installation, operation and maintenance of the Jamesbury™ Model C Cryogenic *Wafer-Sphere* Butterfly Valves. Please read these instructions carefully and save them for future reference.

WARNING:

AS THE USE OF THE VALVE IS APPLICATION SPECIFIC, A NUMBER OF FACTORS SHOULD BE TAKEN INTO ACCOUNT WHEN SELECTING A VALVE FOR A GIVEN APPLICATION. THEREFORE, SOME OF THE SITUATIONS IN WHICH THE VALVES ARE USED ARE OUTSIDE THE SCOPE OF THIS MANUAL.

IF YOU HAVE ANY QUESTIONS CONCERNING THE USE, APPLICATION OR COMPATIBILITY OF THE VALVE WITH THE INTENDED SERVICE, CONTACT VALMET FOR MORE INFORMATION.

1.2 OFFSET SHAFT DESIGN

One of the design features of the Cryogenic *Wafer-Sphere* valve that is responsible for its superior performance is the valve's offset shaft design. The shaft is offset in two planes: (1) away from the valve disc centerline and (2) behind the disc sealing plane (See **Figure 1**). Offset shaft design makes the rotating disc "cam" back and away from the seat, completely eliminating the usual wear points at the top and bottom of the seat. Because the disc rotates off the seat in an eccentric arc, it operates in one quadrant only (See **Figure 1**).

WARNING:

IF THE VALVE DOES NOT HAVE EITHER A FULLY OPERATIONAL ACTUATOR OR A HANDLE, **DO NOT PRESSURIZE THE VALVE**. UNRESTRAINED DISC MAY OPEN OR CLOSE DUE TO PIPELINE PRESSURE.

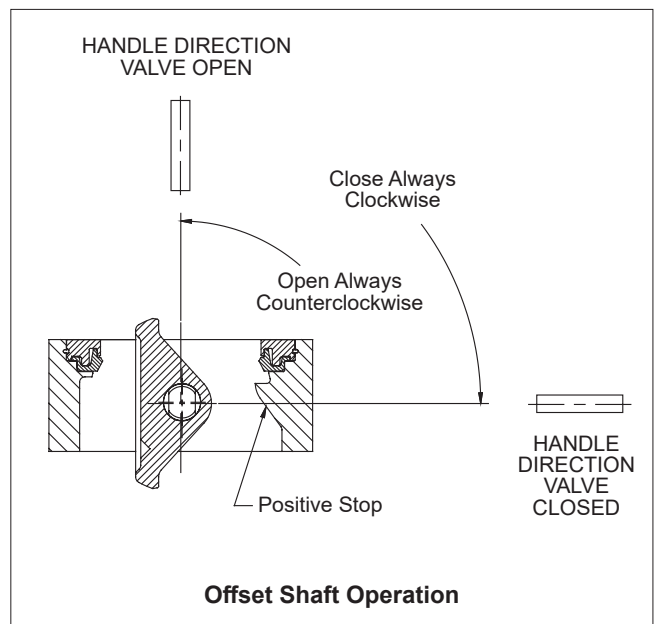

Figure 1.

1.3 POSITIVE STOP FEATURE

To prevent seat damage from over-travel of the disc beyond the closed position (usually during field mounting of a handle or actuator), a "positive stop" feature has been designed into the Cryogenic *Wafer-Sphere* butterfly valve. The "positive stop" feature also makes it possible to adjust the actuator travel stops in-line. The location of this feature is shown in (**Figure 1**).

1.4 ACTUATION

High line pressure may create high enough forces to pull a manual handle out of an operator's hand. With Types K815W, K815L, K830W, and K830L valves, either a manual gear operator, a pneumatic or an electric actuator should be used in place of a detent handle when the differential pressure exceeds those listed in (**Table 1**).

TABLE 1	
Valve Size	Maximum Allowable Differential Pressure for Use With a Detent Handle
3" & 4" (DN 80 & 100)	300 psi (20.7 bar)
5", 6" & 8" (DN 125, 150 & 200)	105 psi (10.35 bar)
10" & 12" (DN 250 & 300)	50 psi (3.45 bar)

1.5 WAFER BODY DESIGN

Some wafer designs (See **Figure 2**) contain flange bolt holes or slots in the body to hold the valve and assist with correct alignment during installation in the line. The centering holes or slots in wafer bodies alone are not suitable, or intended for containing line pressure, and are only for use in conjunction with a fully bolted pipeline flange.

1.6 SNAP-IN INSERTS

Snap-in inserts on wafer style valves must be clamped before cycling the valve when out of the pipeline. Use soft-faced clamps across the body to avoid damaging the gasket surface. Damage to body seals can result if snap-in inserts are not clamped when valve is cycled.

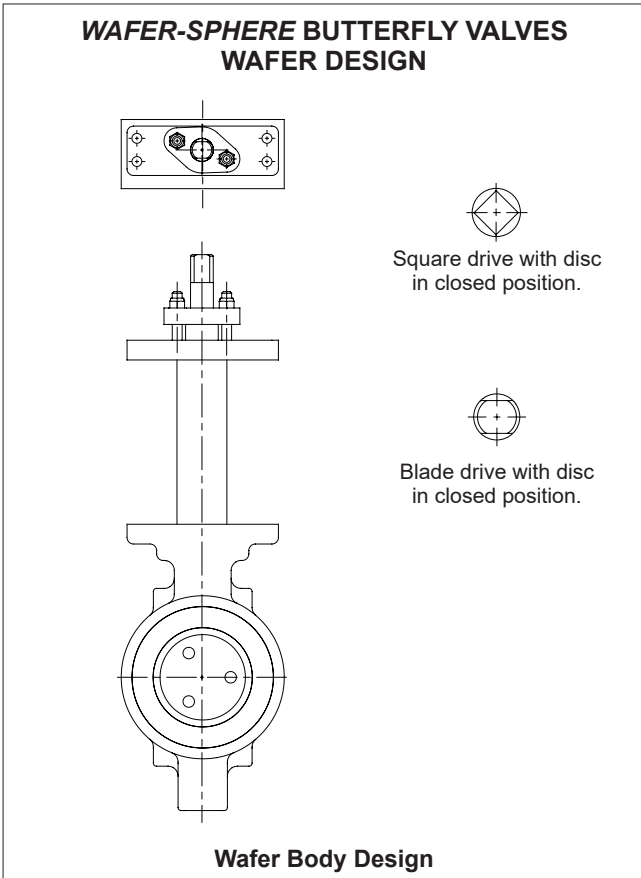

Figure 2.

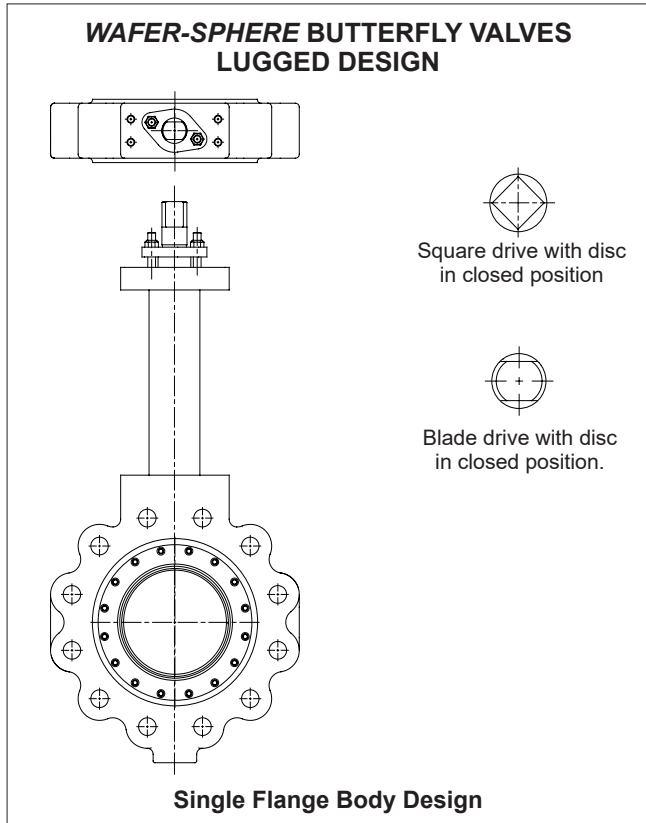

Figure 3.

1.7 VALVE MARKINGS

The valve has an identification plate attached to the valve body (see **Figure 4**).

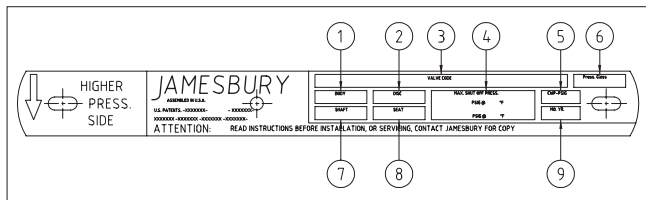

Figure 4. Identification Plate

Identification plate marking:

1. Size
2. Pressure class
3. Type code
4. Body material
5. Seat material
6. Model number
7. Date
8. Trim material
9. Shaft material
10. Maximum shut-off pressure
11. Maximum temperature
12. Certification and approvals, eg. CE, Atex etc.

1.8 SAFETY PRECAUTIONS

WARNING:

DO NOT EXCEED THE VALVE PERFORMANCE LIMITATIONS!

EXCEEDING THE PRESSURE OR TEMPERATURE LIMITATIONS MARKED ON THE VALVE IDENTIFICATION PLATE MAY CAUSE DAMAGE AND LEAD TO UNCONTROLLED PRESSURE RELEASE. DAMAGE OR PERSONAL INJURY MAY RESULT.

WARNING:

SEAT AND BODY RATINGS!

THE PRACTICAL AND SAFE USE OF THIS PRODUCT IS DETERMINED BY BOTH THE SEAT AND BODY RATINGS. READ THE IDENTIFICATION PLATE AND CHECK BOTH RATINGS. THIS PRODUCT IS AVAILABLE WITH A VARIETY OF SEAT MATERIALS. SOME OF THE SEAT MATERIALS HAVE PRESSURE RATINGS THAT ARE LESS THAN THE BODY RATINGS. ALL OF THE BODY AND SEAT RATINGS ARE DEPENDENT ON VALVE TYPE AND SIZE, SEAT MATERIAL, AND TEMPERATURE. DO NOT EXCEED THESE RATINGS!

WARNING:

DO NOT DISMANTLE THE VALVE OR REMOVE IT FROM THE PIPELINE WHILE THE VALVE IS PRESSURIZED!

Dismantling or removing a pressurized valve will result in uncontrolled pressure release. Always isolate the relevant part of the pipeline, release the pressure from the valve and remove the medium before dismantling the valve.

Be aware of the type of medium involved. Protect people and the environment from any harmful or poisonous substances. Make sure that no medium can enter the pipeline during valve maintenance. Failure to do this may result in damage or personal injury.

WARNING:

BEWARE OF DISC MOVEMENT!

KEEP HANDS, OTHER PARTS OF THE BODY, TOOLS AND OTHER OBJECTS OUT OF THE OPEN FLOW PORT. LEAVE NO FOREIGN OBJECTS INSIDE THE PIPELINE. WHEN THE VALVE IS ACTUATED, THE DISC FUNCTIONS AS A CUTTING DEVICE. DISCONNECT ANY PNEUMATIC SUPPLY LINES, ANY ELECTRICAL POWER SOURCES AND MAKE SURE SPRINGS IN SPRING-RETURN ACTUATORS ARE IN THE FULL EXTENDED/RELAXED STATE BEFORE PERFORMING ANY VALVE MAINTENANCE. FAILURE TO DO THIS MAY RESULT IN DAMAGE OR PERSONAL INJURY!

WARNING:

WHEN HANDLING THE VALVE OR VALVE/ACTUATOR ASSEMBLY, TAKE ITS WEIGHT INTO ACCOUNT!

Never lift the valve or valve/actuator assembly by the actuator, positioner, limit switch or their piping. Place lifting devices securely around the valve body. Failure to follow these instructions may result in damage or personal injury from falling parts.

Please consult separate document: instructions for lifting Valmet products. (See Valmet document id: 10LIFT70EN.PDF).

CAUTION:

BEWARE OF NOISE EMISSIONS!

The valve may produce noise in the pipeline. The noise level depends on the application. Observe the relevant work environment regulations on noise emission. This can be measured or calculated using Neles Nelprof software.

1.9 WELDING NOTES

WARNING:

Welding and/or grinding stainless steel and other alloys containing chromium metal may cause the release of hexavalent chromium. Hexavalent chromium(VI) or Cr(VI), is known to cause cancer. Be sure to use all appropriate personal protective equipment (PPE) when welding metals containing chromium.

NOTE:

A qualified welder must do the installation welding. The welder and welding procedure should be qualified in accordance with the ASME Boiler and Pressure Vessel Code Section IX or other applicable regulation.

CAUTION:

To prevent damage to the seat and seals, do not allow the temperature of the seat and body seal area to exceed 94 °C (200 °F).

It is recommended that thermal chucks be used to check the temperature in these areas during welding.

CAUTION:

Ensure that any weld splatter does not fall onto the valve closing members eg. trim or seats. This may damage critical seating surfaces and cause leaks.

2. TRANSPORTATION AND STORAGE

Check the valve and the accompanying devices for any damage that may have occurred during transport.

Store the valve carefully. Storage indoors in a dry place is recommended.

Do not remove the flow port protectors until installing the valve.

Move the valve to its intended location just before installation.

The valve is usually delivered in the closed position.

If the valve(s) are to be stored for a long duration, follow the recommendations of IMO-S1.

3. INSTALLATION

3.1 GENERAL

Remove the flow port protectors and check that the valve is clean inside. Clean valve if necessary.

Flush the pipeline carefully before installing the valve. Foreign objects, such as sand or pieces of welding electrodes, will damage the disc and seats.

3.2 INSTALLING IN THE PIPELINE

WARNING:

THE VALVE SHOULD BE TIGHTENED BETWEEN FLANGES USING APPROPRIATE GASKETS AND FASTENERS COMPATIBLE WITH THE APPLICATION, AND IN COMPLIANCE WITH APPLICABLE PIPING CODES AND STANDARDS. CENTER THE FLANGE GASKETS CAREFULLY WHEN FITTING THE VALVE BETWEEN FLANGES. DO NOT ATTEMPT TO CORRECT PIPELINE MISALIGNMENT BY MEANS OF FLANGE BOLTING! RECOMMENDED FASTENER LENGTHS ARE LISTED IN BULLETIN T104-1.

The valve may be installed in any position and offers tightness in both directions. For lowest operating torque it is recommended, however, that the valve be installed with the body insert towards the higher pressure, (shaft downstream).

1. Read all **WARNINGS!**
2. **IMPORTANT:** Only operating handle stops or actuator stop screws must be used to stop the disc position. DO NOT use the "positive stop" by itself to limit travel.
3. Visually check the position of the disc when valve is in the closed position and the insert is fully compressed. The disc should be parallel to the flanges within 1/32" (0.79mm).
4. Before installing a closed valve in the pipeline, be sure that the handle or actuator is attached so that a counter-clockwise rotation, viewed from above, opens the valve (**See Figure 1**). Fully close the valve again before installing in the pipeline.
5. **THE PIPELINE:** The *Wafer-Sphere* butterfly valve must be centered between flanges to avoid disc-pipe contact which could damage the disc and shaft. Any flange or pipeline welding should be done prior to installation of the valves. If this is impossible, protective covering or shields must be placed in

the pipeline between the valve and the area being welded prior to welding. Not only must the valve be protected against weld slag, but also against any excessive heat, which could cause seat damage. It is essential that all weld slag, rods, debris, tools, etc., be removed from the pipeline before valves are installed or cycled.

6. Secure the valve between flanges. Compress the flange gaskets **EVENLY** by tightening the fasteners in an alternating sequence.
7. It is not recommended to install the valve with the stem on the underneath side because dirt in the pipeline may then enter the body cavity and potentially damage the stem packing (see **Figure 5**).

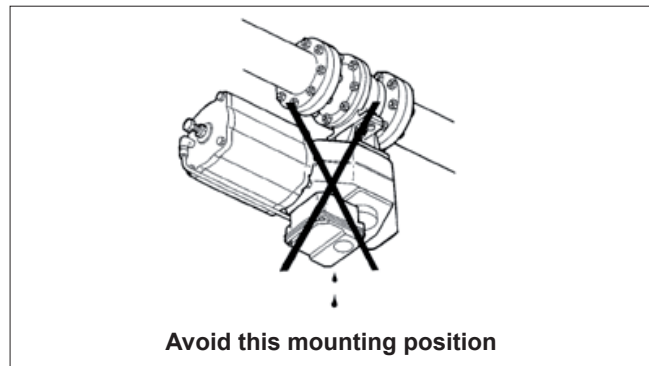

Figure 5.

Refer to the Section 4, **MAINTENANCE** for stem seal adjustment. If there is weepage past the stem seals upon installation, it means the valve may have been subject to wide temperature variations in shipment. Leak-tight performance will be restored by a simple stem seal adjustment described in the **MAINTENANCE** section.

3.3 VALVE INSULATION

If necessary, the valve may be insulated. Insulation must not continue above the upper level of the valve (see **Figure 6**).

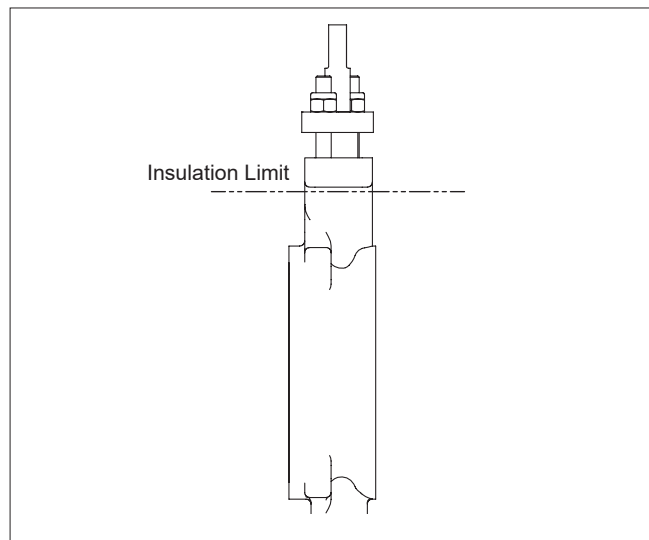

Figure 6. Insulation of the valve

3.4 ACTUATOR

CAUTION:

The actuator must not touch the pipeline, because pipeline vibration may damage it or interfere with its operation. In some certain cases, when a large-size actuator is used, extended stems are required or when the pipeline vibrates heavily, supporting the actuator is recommended.

When installing the actuator on the valve, make sure that the valve package functions properly. See instructions for installing in Section 5.

Observe the space needed for removal of the actuator. The actuator should be installed in a manner that allows plenty of room for its removal.

The upright position is recommended for the actuator cylinder.

In some cases, e.g. when a large-size actuator is used or when the pipeline vibrates heavily, supporting the actuator is recommended.

Please contact Valmet for further information.

3.5 COMMISSIONING

Ensure that there is no dirt or foreign objects left inside the valve or pipeline. Flush the pipeline carefully. Make sure that the valve is fully open when flushing.

Ensure that all nuts, fittings, and cables are properly fastened.

If so equipped, check that the actuator positioner and/or switch are correctly adjusted. To adjust actuator or any accompanying device(s) refer to the separate control equipment instruction manuals.

4. MAINTENANCE

WARNING:

Observe the safety precautions mentioned in Section 1.8 before maintenance!

CAUTION:

When handling the valve or the valve package as a whole, be mindful of the weight of the valve or the entire package.

WARNING:

For safety reasons the shaft seals MUST always be installed according to Section 4.6.

Numbers in () refer to items shown in Figures 8, 9, & 12.

4.1 GENERAL

Although Jamesbury valves are designed to work under severe conditions, proper preventative maintenance can significantly help to prevent unplanned downtime and in real terms reduce the total cost of ownership. Valmet recommends inspecting valves at least every five (5) years. The inspection and maintenance frequency depends on the actual application and process condition. Routine maintenance consists of tightening the hex head cap screws (15) in (Figure 14) periodically to compensate for stem seal wear.

Overhaul maintenance consists of replacing seats and seals. A standard repair kit consisting of these parts may be obtained through your authorized Valmet Distributor.

NOTE: Repair kits include thrust bearings (13), secondary stem seal (7), seats (5), and body seal (6) and stem seals (8). Refer to the Repair Kit chart (see Table 6).

WARNING:

FOR YOUR SAFETY IT IS IMPORTANT THE FOLLOWING PRECAUTIONS BE TAKEN PRIOR TO REMOVAL OF THE VALVE FROM THE PIPELINE OR BEFORE ANY DISASSEMBLY:

1. Wear any protective clothing or equipment normally required when working with the fluid involved.
2. Depressurize the pipeline by placing the valve in the open position and draining the pipeline.

After removal and before any disassembly, cycle the valve again several times.

NOTE:

When sending goods to the manufacturer for repair, do not disassemble them. Clean the valve carefully and flush the valve internals. For safety reasons, inform the manufacturer of the type of medium used in the valve (include material safety datasheets (MSDS)).

NOTE:

In order to ensure safe and effective operation, always use original spare parts to make sure that the valve functions as intended.

NOTE:

For safety reasons, replace pressure retaining bolting if the threads are damaged, have been heated, stretched or corroded.

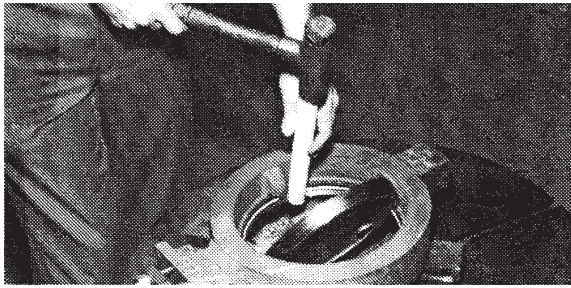

Removing Insert



Placing Spring Into Groove



Tapping End Of Spring Into Body

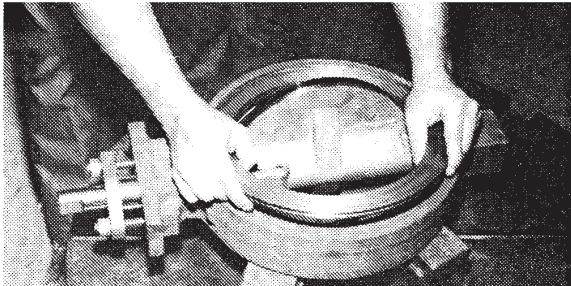

Installing Seat And Insert Assembly Into Body.
Angled As To Engage Insert Spring



Tapping Insert Assembly Into Body

Insert Removal / Installation

4.2 ACTUATED VALVE

It is generally most convenient to detach the actuator and its auxiliary devices before removing the valve from the pipeline. If the valve package is small or if it is difficult to access, it may be more practical to remove the entire assembly.

NOTE: To ensure proper reassembly, observe the position of the actuator and positioner/limit switch with respect to the valve before detaching the actuator.

WARNING:

ALWAYS DISCONNECT THE ACTUATOR FROM ITS POWER SOURCE, PNEUMATIC, HYDRAULIC OR ELECTRICAL, BEFORE ATTEMPTING TO REMOVE IT FROM THE VALVE!

WARNING:

DO NOT REMOVE A SPRING-RETURN ACTUATOR UNLESS A STOP-SCREW IS CARRYING THE SPRING FORCE!

1. Detach the air supply, electrical supply, hydraulic supply and control signal cables or pipes from their connectors.
2. Loosen screws of no-play coupling.
3. Unscrew the actuator mounting bracket screws.
4. Lift the actuator straight up in line with the valve stem until the coupling between actuator drive and valve stem is completely disengaged.
5. Place actuator in a safe location to avoid damage or personal injury.

4.3 VALVE REMOVAL

WARNING:

Do not dismantle the valve or remove it from pipeline while the valve is pressurized.

1. Read all **WARNINGS!**
2. Valve must be fully closed before removing it from the pipeline.
3. **CAUTION:** Valves equipped with spring-to-open (air-to-close) actuators must be disconnected from the actuators and then closed. Valves must be closed while removing them from the pipeline.

Ensure that the valve is not pressurized and the pipeline is empty. Ensure that the medium cannot flow into the section where servicing is to take place. Support the valve carefully with a hoist. Place ropes carefully and unscrew the pipe flange bolts. Ensure that the ropes are positioned correctly.

Figure 7.

4.4 COMPOSITE SEAT REPLACEMENT FOR 3"-12" (DN80-33) VALVES

WARNING:

Do not dismantle the valve or remove it from pipeline while the valve is pressurized.

1. After removing the valve from the line, place it on a bench. Take care not to damage the sealing edge of the valve disc.
2. Insert Styles:
 - A. **Bolted Insert:**
Remove the insert screws (21) and the insert (2). If the insert does not lift out easily, tap it out from the shaft side using a wooden or plastic rod and a hammer. Do not strike the valve directly with a hammer.
 - B. **Snap-In Insert (See Figure 7):**
Using a wooden or plastic rod and hammer, drive the insert out of the body from the shaft side. The rod should be placed on either side of the positive stop in the body. Do not strike the valve directly with a hammer. (**NOTE:** Removal of the insert often results in damage to the seat being replaced.)
3. Remove the seat (5), two body seals (40) and discard it.
4. Carefully clean the gasketing surfaces with a suitable solvent. They should be free of all grooves and scratches. If deep scratches are present, polish or repair is required.
5. Clean the valve, and deburr the insert.
6. Carefully clean and polish the disc sealing surface. It should be free of all grooves and scratches. If the disc is slightly damaged, it may be possible to smooth the sealing surface with crocus cloth, a fine stone, or the equivalent. If deep scratches are present, replace disc or return the valve to the factory for service.
7. Cycle the valve closed.
8. Two body seals (40) are required between the seat tail and the body as shown in (Figure 8 & 14). The valve uses a graphite type gasket. This is installed in accordance with the following steps.
 - a. **IMPORTANT:** Exercise care at all times not to damage the gasket. A break will cause the gasket to leak.
 - b. The bottom surface of the insert must be free of all foreign particles. Clean thoroughly with suitable solvent.
 - c. Apply the two body seals (40) to the body, and if a lug style, take care to align the holes in the gasket with the insert screw holes.
9. Verify the disc is in the level position and install the seat (5) and insert (2) (See Figures 8 & 9).
10. Insert Styles:
 - A. **Bolted Insert:**
Install the insert and screws. Tighten the screws uniformly. Torque valves are given in (Table 2). Open the valve and retorque the insert screws per (Table 2). Take care not to damage the sealing edge of the disc. Close the valve.

B. Snap-In Insert:

Place the insert spring (77) into the groove in the body, opposite the positive stop (See Figure 7). Lightly tap one end of the spring into the body groove. Be sure the spring is positioned snugly into the groove.

TABLE 2		
Insert Screw Torque Table (FT•LBS Unless Otherwise Specified)		
Screw Size	Torque Carbon Steel FT•LBS (N•m)	FT•LBS N•m
#10	50 IN•LBS (6)	23 IN•LBS (3)
1/4"	14 (19)	6 (8)
5/16"	30 (41)	11 (15)
3/8"	50 (68)	20 (27)
7/16"	80 (109)	30 (41)
1/2"	120 (163)	40 (55)

TABLE 3	
Cover Plate Screw Torque Table	
Screw Size	Torque – FT•LBS (N•m)
3/8"	35 (48)
1/2"	80 (109)
9/16"	110 (149)
5/8"	180 (244)
3/4"	270 (366)

Lightly tap the other end of the spring into the groove. Make sure that the ends of the spring are embedded into the body groove to prevent spring movement. With the disc slightly open, install the insert into the body such that it is angled into the body to engage the insert spring. Once the insert spring is engaged, "pop" the opposite side of the insert into the body by lightly tapping the insert with a block of wood and a hammer. Close the valve.

11. Set the handle or actuator stops as described in the **SETTING HANDLE STOP** Section or **MOUNTING INSTRUCTION** Section. Do not install and tighten flanges on a newly resealed valve until the actuator stops are properly set and the valve is fully closed. Incorrect disc positioning may cause damage to a new seat when the valve is compressed between flanges for the first time. **NOTE:** After installation of a new seat, torque will be higher for a few cycles.

4.5 SOLID (PCTFE) SEAT REPLACEMENT FOR 14" (DN350) AND LARGER VALVES

WARNING:

Do not dismantle the valve or remove it from pipeline while the valve is pressurized.

1. After removing the valve from the pipeline, place it on a bench and cycle it open. Take care not to damage the sealing edge of the valve disc.
2. Remove the insert screws (21) and the insert (2). If the insert does not lift out easily, tap it out from the shaft side using a wooden or plastic rod and a hammer. Do not strike the valve directly with a hammer.

3. Remove the seat (5) and discard.
4. Clean the valve and deburr the insert.
5. Carefully clean and polish the disc. It should be free from all grooves and scratches.
6. If the disc is slightly damaged, it may be possible to smooth the sealing surface with crocus cloth, a fine stone, or the equivalent. If deep scratches are present, replace disc or return the valve to the factory for service.
7. Cycle the valve closed.

8. Replace the insert and seat together, using the insert screws, and tighten them uniformly. Torque values are given in **(Table 1)**. Whenever possible, open the valve and retorque the insert screws per **(Table 2)**. Take care not to damage the sealing edge of the disc. Close the valve.
9. Set the actuator stops as described in the **ACTUATOR MOUNTING INSTRUCTIONS** Section. Do not install and tighten flanges on a newly reseated valve until the actuator stops are properly set and the valve is fully closed. Incorrect disc positioning may cause damage to a new seat when the valve is compressed between flanges for the first time. **NOTE:** After installation of a new seat, torque will be higher for a few cycles.

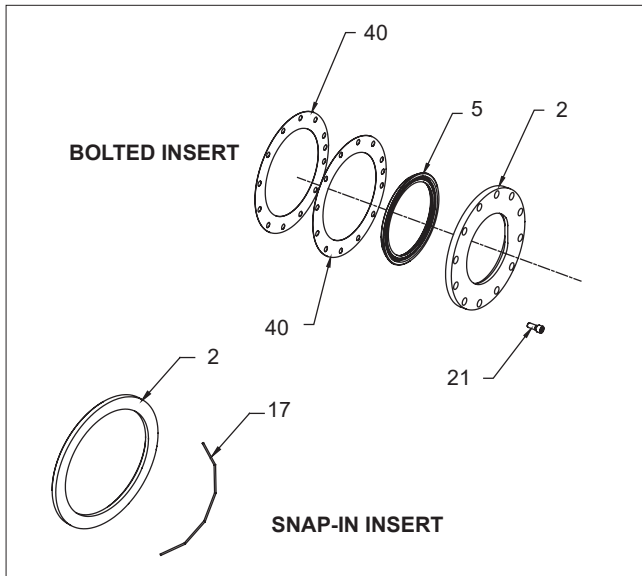

Figure 8.

4.6 SHAFT SEAL REPLACEMENT

WARNING:

Do not dismantle the valve or remove it from pipeline while the valve is pressurized.

NOTE: See IMO-317 for live loaded shaft seals.

CAUTION: Read all **WARNINGS** before proceeding.

1. Remove the handle or actuator coupling. When applicable, remove the indicator pointer (29).
2. Remove the nuts (15) from above the compression plate (10). Remove the compression plate (10). The studs (14) do not have to be removed.
3. Remove C-shaped retainer ring (47) from the shaft.
4. Remove the compression ring (9).
5. Remove the old shaft seal (8) segments. **CAUTION:** Do not score the shaft or body bore!
6. The spacer (7) need not be removed for shaft seal replacement.
7. Replace the old shaft seal with a new shaft seal. **NOTE:** If the seal is of the PTFE V-ring type, keep the seal rings stacked in the same order as removed from kit. Note the orientation in **(Figure 14 or 14A)**. This orientation is preferred for all applications, including vacuum.
8. Reinstall the compression ring (9), the retainer ring (47), the compression plate (10), the nuts (15). **NOTE:** If the compression ring initially sits too high to install the retainer ring it may be necessary to precompress the shaft seals somewhat. In that case, install the compression plate and tighten the nuts enough to accomplish the precompression. Remove the compression plate to install the retainer ring and then complete the reassembly.
9. Close the valve.
10. With the valve closed, tighten the nuts (15) on the compression plate evenly until the packing is adequately compressed to prevent leakage. This should require tightening the nuts approximately 1-1/2 to 2 full turns after they have both come into contact with the compression plate.

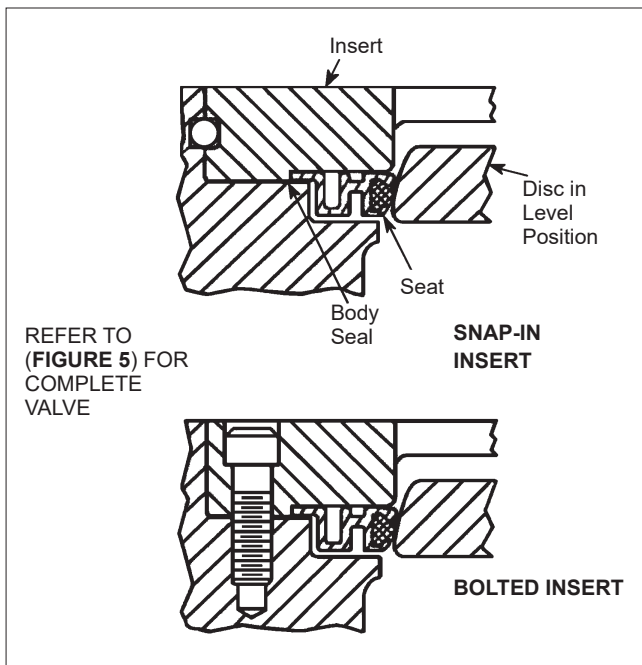

Figure 9.

4.7 VALVE DISASSEMBLY

WARNING:

Do not dismantle the valve or remove it from pipeline while the valve is pressurized.

NOTE: If complete disassembly becomes necessary, replacement of seats and all seals is recommended.

1. Place the valve on a bench or other suitable working space.
2. If the seat is to be replaced or removed, follow Steps 2, 3, 4 and 5 in the **SEAT REPLACEMENT** Section.
NOTE: It is good practice to replace the seat, shaft and body seals and bearings any time a valve is disassembled.
3. Remove the shaft seal compression hardware as detailed in Steps 1-4 in the **SHAFT SEAL REPLACEMENT** Section. The seal material itself can be more easily removed after the shaft has been removed from the valve.
4. Remove the disc pin welds by grinding or machining off the welds. Drive out the pins opposite the installation direction shown in (**Figure 14 & 14A**).
5. Remove screws (55) and cover plate (53), and remove gasket (54), if applicable.
6. Remove the shaft (4). **NOTE:** When removing the shaft and freeing the disc, be careful not to scratch the sealing surface of the disc.
7. Remove the disc (3) and upper and lower thrust bearings (64).
8. Remove the top bearing (6) either through the top of the valve or the waterway.
9. Remove the bottom bearing (6).

4.8 CHECKING PARTS

1. Clean all disassembled parts.
2. Check the shaft (4) and disc (3) for damage. Pay particular attention to the sealing areas.
3. Check all sealing and gasket surfaces of the body (1) and insert (2).
4. Replace any damaged parts.
5. Replace any fastener where the threads are damaged or have been heated, stretched or corroded.
6. Replace any parts that have cracks, gouges or pits that will affect sealing.

NOTE: When ordering spare parts, always include the following information:

- a. Valve catalog code from Identification plate,
- b. If the valve is serialized – the serial number (stamped on the valve body),
- c. From **Figure 14 or 14A**, the ballooned part number, part name and quantity required.

4.9 VALVE ASSEMBLY

NOTE: If complete disassembly becomes necessary, replacement of seats and seals is recommended.

1. Clean all valve components, if not previously done.
2. Inspect all components for damage before assembling the valve. Look for damage to the sealing areas on the disc, shaft, and body, and for wear in the bearing areas.
3. Carefully clean and polish the disc sealing surface. It should be free from all grooves and scratches.
4. If the disc is slightly damaged, it may be possible to smooth the sealing surface with crocus cloth, a fine stone, or the equivalent. If deep scratches are present, replace the disc or return the valve to the factory for service.
5. Install the bottom bearing bearings (6) into the lower body bores. Install the top bearing spacer (41), when applicable, and the top shaft bearing (6) into the upper body bore.
6. To ease assembly of the shaft into the disc, it may be necessary to coat the shaft and the disc bore lightly with a lubricant compatible with the media to be handled by the valve.
7. Slide the shaft through the top bearing and engage the top thrust bearing (64). With the two pin holes toward the bonnet, place the disc in the waterway and slide the shaft through the shaft bore in the disc. Place the lower thrust bearing (64) below the disc, slide the shaft through and into the lower shaft bearing (6). Use caution to prevent damage to the shaft bearings and disc sealing surface.
8. Insert the disc pins (13), as shown in (**Figure 14 & 14A**), and drive them into place. The pins must be driven so that both pins are the same depth within 1/16" (1.56 mm). When they are correctly installed the drive shaft will be as shown in (**Figures 2 and 3**). Weld both ends of the pins, small end first, grounding the shaft only (body on blocks of wood). After the disc cools, clean the welds with a wire brush. **CAUTION:** Use care to keep contamination out of the valve.
9. Install the spacer (7) with chamfered side toward disc, the shaft seal (8), the compression ring (9) and the retainer ring (47). If the shaft seal is of the PTFE V-ring type, be certain that it is installed in the orientation shown in (**Figure 14 & 14A**).
10. If the studs (14) have been removed from the valve, reinstall them in the holes shown in (**Figure 14 & 14A**). For continuously threaded studs only, use LOCTITE® or other locking compound to prevent vibration loosening. For double ended studs, LOCTITE® application is not necessary. Stud protrusion should be the length listed in **TABLE 6**.
11. For valves with a cover plate, install new gasket (54), and secure cover plate to valve body using screws (55). To ensure even gasket loading tighten screws, in an alternating sequence to torque in (**Table 3**).
12. If the handle ratchet plate has been removed from the valve, reinstall it in the orientation shown in (**Figure 11**). Install lock washers and screws in the two bonnet holes. Do not tighten the screws until the stops are set. (See **SETTING HANDLE STOP** Section or **ACTUATOR MOUNTING INSTRUCTIONS** Section.)
13. Place the compression plate (10) over the shaft (4) and studs (14). Install the nuts (15), but do not tighten.

14. Cycle the valve fully closed. Install new unused seat and body seal. See the **SEAT REPLACEMENT** Section for details.
15. With the valve still closed, tighten the nuts (15) on the compression plate evenly until the shaft seals are adequately compressed to prevent leakage. This should require tightening the nuts approximately 1-1/2 to 2 full turns after they have both come into contact with the compression plate.
16. Set the handle or actuator stops as described in the **SETTING HANDLE STOP** Section or **ACTUATOR MOUNTING INSTRUCTIONS** Section. Tighten the screws holding the ratchet plate.
10. If leakage is detected, vent the valve and make an actuator close-stop adjustment as described in the appropriate *Jamesbury* actuator IMO, listed in **Table 4**.
11. Repressurize the valve and check the leakage. If valve still leaks, repeat step 10. If leakage cannot be stopped, adjust the actuator stop so that leakage is minimized.
12. Rebuilt valves may have some minor leakage due to damage to the disc. With the valve still pressurized, insert the free end of the tube/hose into a beaker of water and check for bubbles. In the absence of other test standards, observe leakage after it has reached a stable condition. Because of the volume of air that must be exhausted from a cycled valve, it may be necessary to wait several minutes for the leakage to stabilize or stop. One bubble per inch (25.4 mm) of valve diameter per minute may be considered acceptable for rebuilt solid or composite seated valves.

4.10 TESTING THE VALVE

WARNING:

WHEN PRESSURE TESTING, EXERCISE CAUTION AND MAKE SURE ALL EQUIPMENT USED IS IN GOOD WORKING CONDITION AND APPROPRIATE FOR THE INTENDED PRESSURE.

Should it become necessary to perform a leak test of the valve prior to its installation in the pipeline, follow the procedure outlined below.

1. In the following test, suitable gaskets are required between the faces of the valve and the test hardware.
2. Before pressurizing the valve be sure all actuator linkage fasteners are tight, and that the power or pressure is applied to the actuator to maintain the valve in the closed position. The offset design on the valve may cause it to rotate when the test pressure is applied to one side of the disc.
3. The valve should be installed between flanges or in a testing apparatus. If flanges are used, refer to **INSTALLATION** Section. If a testing device other than flanges is used, the clamping force of the device must be comparable with flange bolt loads on the valve.
4. Slightly open the valve. Verify that you do not have a seal between the seat and the disc. Exercise caution when cycling a valve in the test apparatus to avoid possible disc damage from the disc striking the test fixture.
5. Cap the downstream vent and apply 100 psi (6.9 bar) to the valve. Check the shaft seals, and flange gaskets for leakage. This can be done by applying a liquid mixture of soap and water at all seal joints and watching for bubbles.

IMPORTANT: If leakage is detected between the valve and flanges **STOP IMMEDIATELY**. Mark the area of leakage. Vent the valve, and when it has returned to 0 psi (0 bar), retighten the flange bolts in the area. Repressurize the valve checking the gasket again. If leakage persists, disassemble and inspect for damage.

6. If leakage is detected at the shaft seals, tighten the bonnet nuts only enough to stop the leak.
7. Vent the valve, and when it has returned to 0 psi (0 bar), cycle the valve closed.
8. Attach a small tube or hose to the downstream flange (shaft side of the valve).
9. Be sure power/pressure is still applied to the actuator. Pressurize the upstream flange (insert side of valve) to 100 psi (6.9 bar). Check for leakage passing through the free end of the tube/hose.

5. MANUAL HANDLES

5.1 GENERAL

1. Depressurize the line.
2. 2-1/2" thru 6" (DN 65 thru 150) Valves - To ensure proper handle/shaft engagement, the handle must be mounted on the shaft such that it rests on the bottom of the shaft blade. (**See Figure 10**)
3. 8", 10" and 12" (DN 200, 250, and 300) Valves - Handles for these valves are of solid cast construction. Adjusting these handles along the blade to assure proper ratchet plate engagement is permitted. **NOTE:** Handles not available on square drives.

5.2 CHANGE OF HANDLE QUADRANT

If it is necessary to remount the handle 180 degrees from its standard direction (**See Figure 11**).

1. Depressurize the line. Remove the handle, hex head cap screws (H6) and lockwashers (H7). Do not remove the studs (14), nuts (15), or compression plate (10).
2. Lift the ratchet plate up and rotate it 180 degrees. Do not turn it upside down.

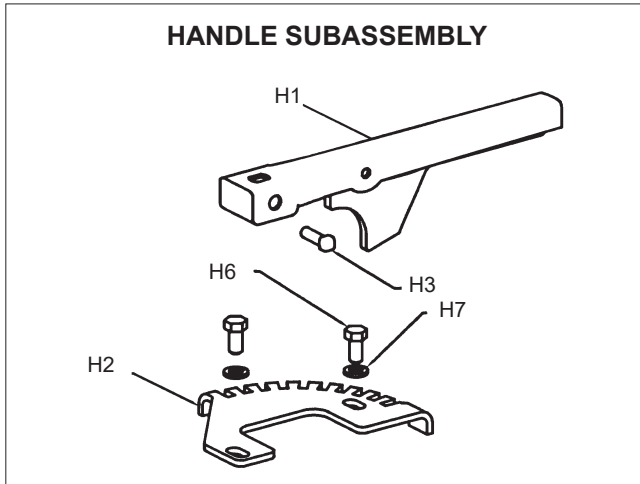

Figure 10.

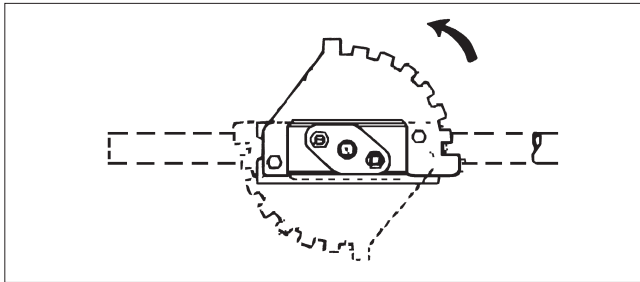

Figure 11.

3. Reinstall all the components which were just removed. Do not tighten the ratchet plate fasteners until the plate has been properly adjusted as described below in the **SETTING HANDLE STOP** Section. If the valve is not installed in the line, do not install it until the ratchet plate is properly adjusted.

5.3 SETTING HANDLE STOP

1. It is recommended that the valve be out of the pipeline for proper adjustment. If this is not possible, valve must be depressurized before adjustment is made.
2. Loosen the two hex head cap screws (H6) clamping the ratchet plate to the valve.
3. Close the valve until the disc is parallel with the flange faces within 1/32" (.79 mm). Do not over close the valve, so that the disc is in contact with the positive stop in the body.
4. If the handle (H1 in **Figure 8-1**) has been removed from the valve, reinstall it on the shaft drive blade and tighten. Cast handles use a screw (H3) and nut (H5). Fabricated handles use only a set screw (H3). With the handle locking tab in the last (closed) notch of the ratchet plate, rotate the ratchet plate clockwise (when viewed from above the handle) until it is stopped by the locking tab. The disc/handle assembly is now trapped between the disc stop in the body and the ratchet plate.
5. Tighten the two screws (H6) holding the ratchet plate.

6. ACTUATOR

WARNING:

BEFORE INSTALLING THE VALVE AND ACTUATOR, BE SURE THAT THE INDICATOR POINTER ON TOP OF THE ACTUATOR IS CORRECTLY INDICATING THE VALVE POSITION. FAILURE TO ASSEMBLE THESE PRODUCTS TO INDICATE CORRECT VALVE POSITION COULD RESULT IN DAMAGE OR PERSONAL INJURY.

Caution: When installing a linkage or servicing a valve/actuator assembly, the best practice is to remove the entire assembly from service.

Caution: An actuator should be remounted on the valve from which it was removed. The actuator must be readjusted for proper open and close position each time it is remounted.

WARNING:

The linkage has been designed to support the weight of the *Jamesbury* actuators and recommended accessories. Use of this linkage to support additional equipment such as people, ladders, etc. may result in the failure of the linkage, valve or actuator and may cause personal injury.

WARNING:

WHEN MOUNTING THE ACTUATOR MAKE SURE THAT THE VALVE AND ACTUATOR ARE BOTH IN THE SAME POSITION. MOUNTING AN OPEN ACTUATOR TO A CLOSED VALVE MAY RESULT IN VALVE STEM DAMAGE.

NOTE: When a single-acting STMS pneumatic spring-return actuator is mounted to a *Wafer-Sphere* valve, it can be mounted only in the spring-to-close mode (air-to-open).

CAUTION:

Before dismantling, carefully observe the position of the valve with respect to the actuator and positioner/limit switch so as to ensure that the package can be properly reassembled. Mounting an open actuator to a closed valve may result in valve stem damage.

CAUTION:

When handling the valve or the valve package, bear in mind its weight!

WARNING:

Do not detach a spring-return actuator unless a stopscrew is carrying the spring force!

CAUTION:

Do not turn the disc more than 90° as this could damage the seat. The valve is so constructed that the disc operates only between 0-90°.

NOTE:

When Valmet supplies whole valve-actuator assembly, the actuator is mounted at Valmet factory on the valve and the stroke limit stops are adjusted by Valmet.

6.1 ACTUATOR MOUNTING INSTRUCTIONS

1. When a spring-return actuator is being mounted, the valve should be in the closed position for spring-to-close operation or in the open position for the spring-to-open operation. When an electric or double-acting pneumatic actuator is being mounted, the valve position should correspond to the indicated actuator position.
2. Assemble bracket to actuator as shown in **(Figure 12)**. Tighten to torque listed in **(Table 5)**.
3. Place the coupling onto the valve stem. If the valve has a two-piece "no-play" bolted coupling, assemble the coupling loosely on the valve stem. Use socket head cap screws and lock nuts. **(See Figure 13)**

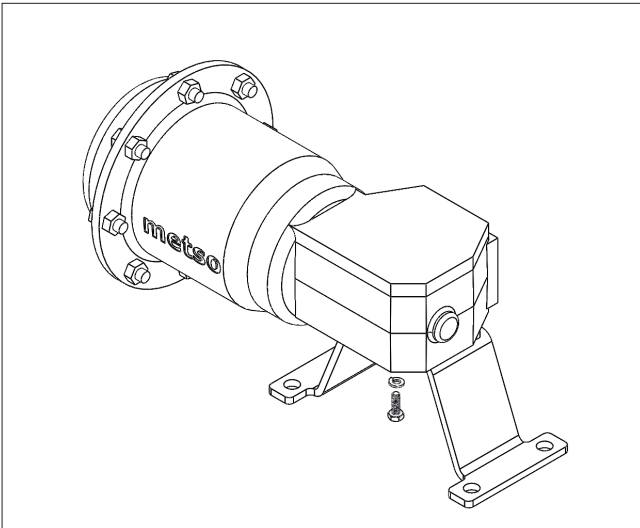

Figure 12.

Actuator	IMO
Quadra-PowR	IMO-31, 32
ST-50	IMO-22
ST-60, 90, 115, 17SMS	IMO-23
ST-200/400	IMO-26
ST-600/1200	IMO-24, 38
ST160, 240, 290, 440MS	IMO-27, 39
ST-1800	IMO-506
Manual Gears	IMO-63
SP	IMO-512
BC, B1C	5 BC 70-A
BJ, B1J	5 BJ 70-A
EU Series	IMO-515
ER Series	IMO-516

4. Lower actuator and bracket onto valve while engaging actuator stem driver into coupling. Tighten screws just enough to firmly mate bracket to valve. This should allow bracket to shift, allowing the coupling to align the valve and actuator shafts **(See Figure 15, Step 3A)**.
5. Tighten the no-play coupling screws to torques shown in **(Figure 15, Step 3B)**. Use alternating sequence shown.

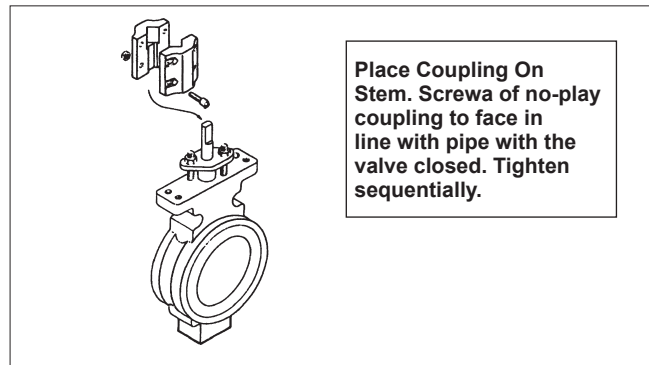

Figure 13.

6. Cycle actuator. See actuator instructions.
7. Fully tighten the screws holding the bracket to the valve, as shown in **(Figure 15, Step 3C)**.
8. Recheck no-play coupling screw torques, using the torques in **(Figure 165 Step 3B)**. Use alternating sequence shown.
9. Adjust the actuator travel stops as described in the actuator instructions to these proper valve open and closed positions:

Valve Open:

Disc face (or shaft blade) perpendicular with the flange face.

Valve Closed:

Disc face parallel to flange face within 1/32" (.79 mm).

6.2 DIRECT DRIVE MOUNTING

Follow instructions per Paragraph 6.1 except for coupling assembly (See Figure 16).

7. REPAIR KITS

Standard repair kits are listed in (Table 7). When ordering repair kits for your valve refer to Section 1.7, Valve Markings and check area “3” on your valve’s identification plate to determine the correct seat material for your valve.

8. SERVICE / SPARE PART

We recommend that valves be directed to our service centers for maintenance. The service centers are equipped to provide rapid turn-around at a reasonable cost and offer new valve warranty with all reconditioned valves.

NOTE: When sending goods to the service center for repair, do not disassemble them. Clean the valve carefully and flush the valve internals. Include the material safety datasheet(s) (MSDS) for all media flowing through the valve. Valves sent to the service center without MSDS datasheet(s) will not be accepted.

For further information on spare parts and service or assistance visit our web-site at www.valmet.com/flowcontrol.

NOTE: When ordering spare parts, always include the following information:

- a. Valve catalog code from identification plate,
- b. If the valve is serialized – the serial number (from identification plate)
- c. From Figure 14, the ballooned part number, part name and quantity required

9. ASSEMBLY AND PARTS LIST

EXPLODED VIEW AND PARTS LIST 3" – 12" (DN 80 – 300) Wafer and Lugged Style Cryogenic Valves

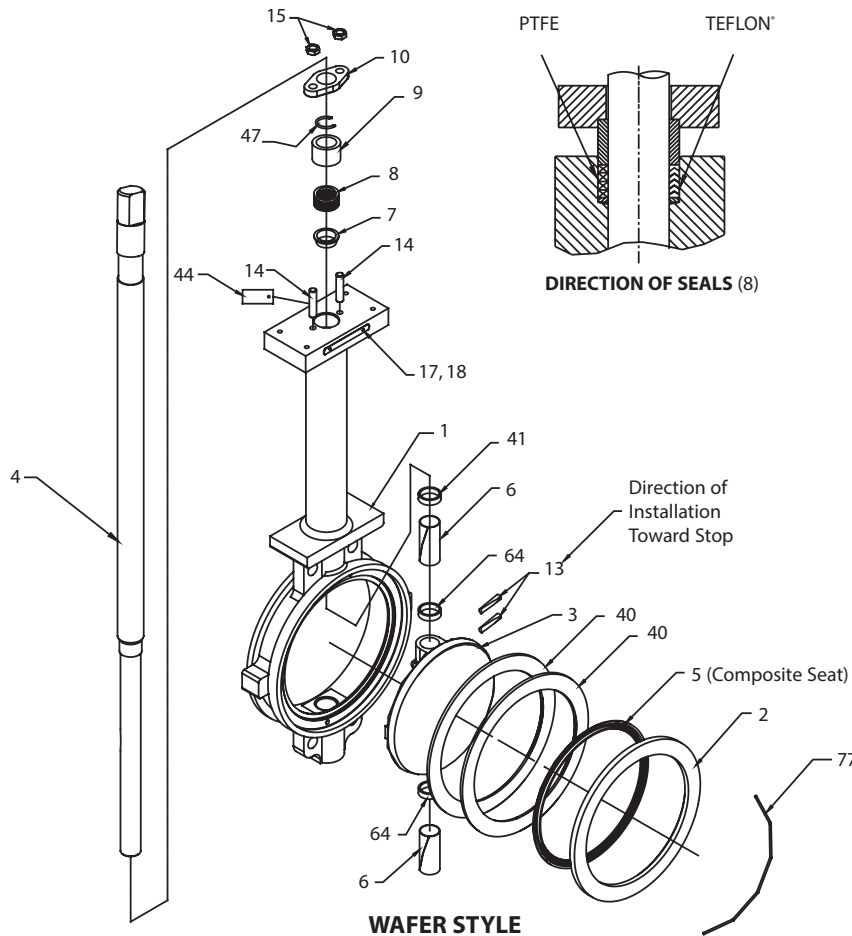

PARTS LIST		
ITEM	PART NAME	QTY
1	Body	1
2	Insert	1
3	Disc	1
4	Shaft	1
5+	Seat	1
6	Shaft Bearing	2
7	Spacer	1
8+	Shaft Seal	1
9	Compression Ring	1
10	Compression Plate	1
13	Disc Pin	2
14	Stud	2
15	Nut	2
17	Nameplate	1
18	Pop Rivet	2
21	Cap Screw (lugged style only)	*
40	Body Seal	2
41	Top Bearing Spacer (not on all sizes)	1
44	Paper Tag	1
47+	Retaining Ring	1
64	Thrust Bearing	2
77+	Insert Spring (Wafer Style Only)	1

+ Parts contained in repair kit.
* Quantities vary by valve size and class.

Figure 14.

EXPLODED VIEW AND PARTS LIST

14" (DN 350) and Larger Wafer and Lugged Style Cryogenic Valves

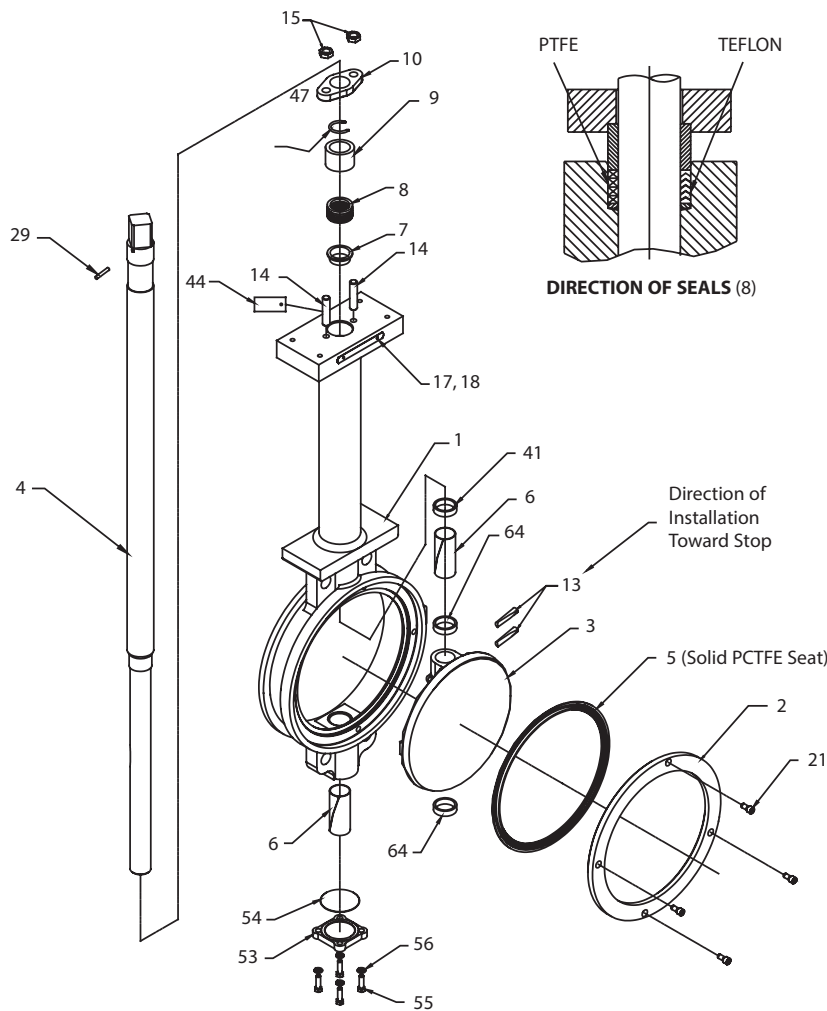

PARTS LIST		
ITEM	PART NAME	QTY
1	Body	1
2	Insert	1
3	Disc	1
4	Shaft	1
5+	Seat	1
6	Shaft Bearing	2
7	Spacer	1
8+	Shaft Seal	1
9	Compression Ring	1
10	Compression Plate	1
13	Disc Pin	*
14	Stud	2
15	Nut	2
17	Nameplate	1
18	Pop Rivet	2
21	Cap Screw	*
29	Indicator Pointer (Square Drives Only)	1
41	Top Bearing Spacer (Not on all sizes)	1
44	Paper Tag	1
47+	Retaining Ring	1
53	Cover Plate	1
54	Gasket	1
55	Hex Head Cap Screw	#
56	Lockwasher	#
64	Thrust Bearing	2

+ Parts contained in repair kit
 * Quantities vary by valve size and class

Figure 14a

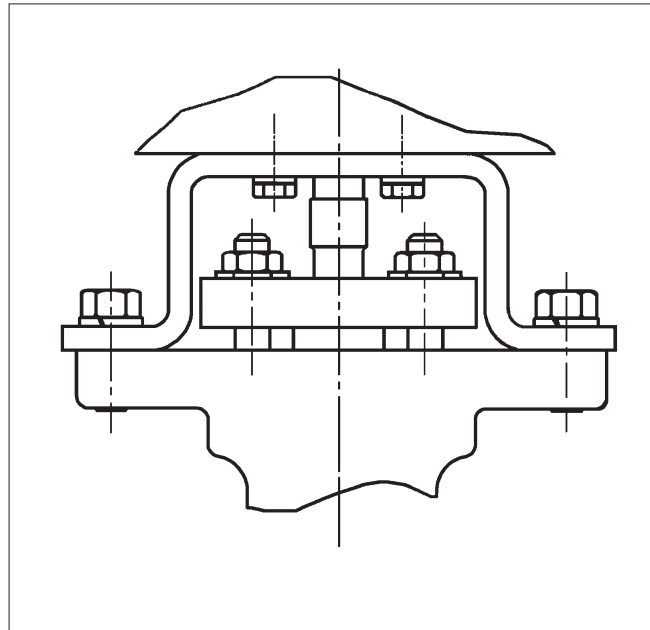
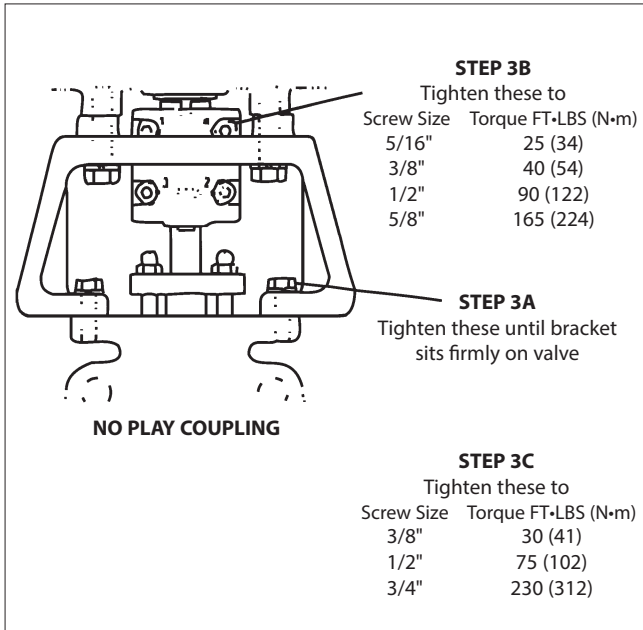

Figure 15.

Figure 16.

TABLE 5				
Bracket Bolting Torques for GR.5 Hex Cap Screws				
Bolt Size	Torque to Aluminum Body Actuators		Torque to Cast/Ductile Body Actuators	
	No Lubrication to Screws			
inches	FT•LBS	N•m	FT•LBS	N•m
1/4	6	-	8	-
5/16	12	-	16	-
3/8	20	-	27	-
7/16	30	-	45	-
1/2	50	-	67	-
9/16	70	-	100	-
5/8	90	-	135	-
3/4	160	-	225	-
7/8	250	-	335	-
1	360	-	520	-
1-1/8	520	-	700	-
1-1/4	700	-	990	-
M6	-	6.8	-	9.5
M8	-	14.9	-	19.0
M10	-	30	-	38
M12	-	52	-	65
M16	-	122	-	156
M20	-	230	-	305
M30	-	773	-	1062
M36	-	1288	-	1826

TABLE 6											
Compression Plate Stud Protrusion											
Class 150						Class 300					
Valve Size		Extension Length		Stud Protrusion		Valve Size		Extension Length		Stud Protrusion	
NPS	DN	inches	mm	inches	mm	NPS	DN	inches	mm	inches	mm
3"	80	All	All	1.84	46.7	3"	80	All	All	1.84	46.7
4"	100	All	All	1.84	46.7	4"	100	10" - 26"	254 - 660	1.84	46.7
6"	150	10" - 26"	254 - 660	1.84	46.7	4"	100	28" - 36"	711 - 914	2.25	57.2
6"	150	28" - 36"	711 - 914	2.25	57.2	6"	150	All	All	2.25	57.2
8"	200	All	All	2.25	57.2	8"	200	All	All	2.25	57.2
10"	250	All	All	2.25	57.2	10"	250	14" - 40"	356 - 1016	2.25	57.2
12"	300	All	All	2.25	57.2	10"	250	42" - 50"	1067 - 1270	2.06	52.3
14"	350	All	All	2.06	52.3	12"	300	All	All	2.06	52.3
16"	400	All	All	2.06	52.3	14"	350	All	All	2.06	52.3
18"	450	All	All	2.06	52.3	16"	400	All	All	2.06	52.3
20"	500	All	All	2.06	52.3	18"	450	All	All	2.56	65.0
24"	600	All	All	2.56	65.0	20"	500	All	All	3.31	84.1
30"	750	All	All	3.31	84.1	24"	600	All	All	3.50	88.9

TABLE 7							
CRYOGENIC WAFER-SPHERE BUTTERFLY VALVE REPAIR KITS							
CLASS 150 VALVES – K815				CLASS 300 VALVES – K830			
Size	Extension Length in. (mm)	Wafer Style	Lugged Style	Size	Extension Length in. (mm)	Wafer Style	Lugged Style
3" (DN 80) K815	8" – 36" (203 – 914)	RKW-474	RKW-475	3" (DN 80) K830	8" – 36" (203 – 914)	RKW-474	RKW-475
4" (DN 100) K815	10" – 36" (254 – 914)	RKW-476	RKW-477	4" (DN 100) K830	10" – 26" (254 – 660) 28" – 36" (711 – 914)	RKW-476 RKW-494	RKW-477 RKW-495
6" (DN 150) K815	10" – 26" (254 – 660) 28" – 36" (711 – 914)	RKW-478 RKW-480	RKW-479 RKW-481	6" (DN 150) K830	10" – 26" (254 – 660) 28" – 36" (711 – 914)	RKW-480 RKW-496	RKW-481 RKW-497
8" (DN 200) K815	12" – 32" (305 – 813) 34" – 42" (864 – 1067)	RKW-482 RKW-484	RKW-483 RKW-485	8" (DN 200) K830	12" – 32" (305 – 813) 34" – 42" (864 – 1067)	RKW-484 RKW-498	RKW-485 RKW-499
10" (DN 250) K815	12" – 40" (305 – 1016) 42" – 50" (1067 – 1270)	RKW-486 RKW-488	RKW-487 RKW-489	10" (DN 250) K830	14" – 40" (356 – 1016) 42" – 50" (1067 – 1270)	RKW-488 RKW-500	RKW-489 RKW-501
12" (DN 300) K815	14" – 40" (356 – 1016) 42" – 50" (1067 – 1270)	RKW-490 RKW-492	RKW-491 RKW-493	12" (DN 300) K830	14" – 40" (356 – 1016) 42" – 50" (1067 – 1270)	RKW-492 RKW-502	RKW-493 RKW-503
14" (DN 350) K815	16" – 50" (406 – 1270)	RKW-647	RKW-647	14" (DN 350) K830	16" – 50" (406 – 1270)	RKW-649	RKW-649
16" (DN 400) K815	16" – 38" (406 – 965) 40" – 60" (1016 – 1524)	RKW-927 RKW-928	RKW-927 RKW-928	16" (DN 400) K830	18" – 60" (457 – 1524)	RKW-650	RKW-650
18" (DN 450) K815	18" – 60" (457 – 1524)	RKW-929	RKW-929	18" (DN 450) K830	20" – 60" (508 – 1524)	RKW-651	RKW-651
20" (DN 500) K815	18" – 60" (457 – 1524)	RKW-637	RKW-637	20" (DN 500) K830	22" – 72" (559 – 1829)	RKW-652	RKW-652
24" (DN 600) K815	24" – 60" (610 – 1524)	RKW-638	RKW-638	24" (DN 600) K830	24" – 72" (610 – 1829)	RKW-653	RKW-653
30" (DN 750) K815	26" – 72" (660 – 1829)	RKW-648	RKW-648				

10. TYPE CODE

JAMESBURY SERIES K815 AND K830 WAFER-SPHERE VALVES

WARNING:

As the use of the valve is application specific, a number of factors should be taken into account when selecting a valve for a given application. Therefore, some of the situations in which the valves are used are outside the scope of this manual. If you have any questions concerning the use, application or compatibility of the valve with the intended service, contact Valmet for more information.

1	2	3	4	5	6	7	8
3	K815	W	-	26	36	HB	AS

1. sign	VALVE SIZE (inch / mm)
INCHES	3, 4, 6, 8, 10, 12, 14, 16, 18, 20, 24, 30
DN	80, 100, 150, 200, 250, 300, 350, 400, 450, 500, 600, 750

2. sign	VALVE SERIES & STYLE
K815	Standard ANSI Class 150
K830	Standard ANSI Class 300
K860	Standard ANSI Class 600

3. sign	BODY STYLE
W	Wafer
L	Single-flange Lugged

4. sign	CONSTRUCTION / SPECIAL SERVICE
-	Standard (no entry)
O	Oxygen

5. sign	BONNET EXTENSION LENGTHS
8-72	Bonnet extension lengths are available in 2-inch increments. See Bulletin W130-1

6. sign	BODY MATERIAL
35	Alloy 20 (CN7M)
36	Stainless Steel (CF8M)
71	Monel® (M-35-1)

7. sign	DISC AND SHAFT MATERIAL *
75**	Monel disc and K-Monel shaft
HB	316 Stainless Steel disc, 17-4 PH shaft

** Use code 00 when body in Monel.

8. sign	SEAT AND SEAL MATERIAL
STANDARD	
AS	PTFE / 316SS Seat; PTFE seals ***
KT	PCTFE (standard for 14" (DN350) and larger seats; PTFE seals
AP	PTFE / Monel Seat; PTFE seals***
AJ	PCTFE / 316SS Seat; PTFE seals***

** Body Seal of 3"-12" (DN80-300) is graphite.

Monel® is a registered trademark of Special Metals Corporation.

11. GENERAL SAFETY WARNINGS AND DISCLAIMERS

General safety warnings

Lifting

1. Always use a lifting plan created by a qualified person to lift this equipment. Lifting guidance is provided in this IMO (Installation, Maintenance and Operation manual) to assist in lifting plan development. Think about the center of gravity (CG) of the equipment being lifted. Make sure the CG is always under the central lifting point.
2. Valves may be equipped with lifting threads on the body or on the flanges. These are intended to be used with the lifting plan.
3. Use only correct and approved lifting devices. Ensure that lifting devices and straps are securely attached to the equipment prior to lifting.
4. Check, that lifting devices are not damaged and in good condition with a valid check stamp prior to use.
5. Workers must be trained for lifting and handling valves.
6. Never lift an assembly by the instrumentation (solenoid, positioner, limit switch, etc.) or by the instrumentation piping. Straps and lifting devices should be fitted to prevent damage to instrumentation and instrumentation piping. Failure to follow the lifting guidance provided may result in damage and personal injury from falling objects.

Work activities on the valve

1. Wear your personal safety equipment. Personal safety equipment includes but is not limited to protective shoes, protective clothing, safety glasses, helmet, hearing protection and working gloves.
2. Always follow the local safety instructions in addition to the Valmet instructions. If Valmet instructions conflict with local safety instructions, stop work and contact Valmet for more information.
3. Before beginning service on the equipment, make sure that the actuator is disconnected from any kind of power source (pneumatic, hydraulic, and/or electric), and no stored energy is applied on the actuator (compressed spring, compressed air volumes, etc.). Do not attempt to remove a spring return actuator unless the stop screw is carrying the spring force.
4. Make sure that there is a LOTOTO (Lock Out / Tag Out / Try Out) procedure in place for the system in which the valve is installed and strictly follow it.
5. Always make sure that the pipeline is depressurized and in ambient temperature condition before maintenance work is started.
6. Keep hands and other body parts out of the flow port when the valve is being serviced and the actuator is connected to the valve. There is a high risk of serious injury to hands and/or fingers due to malfunction if the valve suddenly starts to operate.
7. Beware of Trim (Disc, Ball or Plug) movement even when the valve is disassembled. Trim may move simply due to the weight of the part or change in position of the valve. Keep hands or other body parts away from locations where they may be injured by movement of the trim. Do not leave objects near or in the valve port which may fall in and need to be retrieved.

General disclaimers

Receiving, handling and unpacking.

1. Respect the safety warnings above!
2. Valves are critical components for pipelines to control high pressure fluids and must therefore be handled with care.
3. Store valves and equipment in a dry and protected area until the equipment is installed.
4. Do not exceed the maximum storage temperatures given in the IMO (installation, maintenance, and operating instructions).
5. Keep the original packaging on the valve as long as possible to avoid environmental contamination by dust, water, dirt, etc.
6. Remove the valve endcaps just before mounting into the pipeline.
7. FOR YOUR SAFETY IT IS IMPORTANT TO FOLLOW THESE PRECAUTIONS BEFORE REMOVAL OF THE VALVE FROM THE PIPELINE OR ANY DISASSEMBLY:
 - Be sure you know what flow medium is in the pipeline. If there is any doubt, confirm with the proper supervisor.
 - Wear any personal protective equipment (PPE) required for working with the flow medium involved in addition to any other PPE normally required.
 - Depressurize the pipeline, bring to ambient temperature, and drain the pipeline flow medium.
 - Cycle the valve to relieve any residual pressure in the body cavity.
 - After removal but before disassembly, cycle the valve again until no evidence of trapped pressure remains.
 - The valves with offset shaft (Butterfly, eccentric rotary plug) have greater trim area on one side of the shaft. This will cause the valve to open when pressurized from the preferred direction without a locking handle or an actuator installed.
 - **WARNING: DO NOT PRESSURIZE THE ECCENTRIC VALVE WITHOUT A HANDLE OR AN ACTUATOR MOUNTED ON IT!**
 - **WARNING: DO NOT REMOVE A HANDLE OR AN ACTUATOR FROM AN ECCENTRIC VALVE WHILE PRESSURIZED!**
 - Before installing the eccentric valve in or remove it from the pipeline, cycle the valve closed. Eccentric valves must be in the closed position to bring the trim within the face to face of the valve. Failure to follow these instructions will cause damage to the valve and may result in personal injury.

Operating

8. The identification plate (ID-plate, type plate, nameplate, or engraved markings) on the valve gives the information of max. process conditions to the valve.
9. (For soft seats) The practical and safe use of this product is determined by both the temperature and pressure ratings of the seat and body. Read the identification plate and check both ratings. This product is available with a variety of seat materials. Some seat materials have pressure ratings that are lower than the body ratings. All body and seat ratings are dependent on the valve type, size and material of the body and seat. Never exceed the marked rating.

10. Temperatures and pressures must never exceed values marked on the valve. Exceeding these values may cause uncontrolled release of pressure and process medium. Damage or personal injury may result.
11. The operating torque of the valve may rise over time due to wear, particles or other damage of the seat. Never exceed the actuator torque preset values (air supply, position). Application of excessive torque may cause damage to the valve.
12. Valmet valves typically are designed to be used in atmospheric conditions. Do not use valves under external pressurized conditions unless specifically designed and explicitly marked for this service.
13. Avoid Pressure shocks or water hammer. Systems with high pressure valves should be equipped with a bypass to reduce the differential pressure before opening the valve to avoid pressure shock.
14. Avoid thermal shock. High temperature, Low temperature and cryogenic valves should be operated in a way that limits the rate of increase or decrease in temperature. The valve should be thermally stabilized before being pressurized.
15. Materials of the valve are carefully selected for the process conditions. Changes to the process media can have a major impact on function and safety of the valve. Always confirm the materials are suitable for the service prior to installation.
16. As the use of the valve is application specific, several factors should be considered when selecting a valve for a given application. Therefore, some situations in which the valves are used are outside the scope of this manual.
17. It is the end user's responsibility to confirm compatibility of the valve materials with the intended service, however if you have questions concerning the use, application, or compatibility of the valve for the intended service, contact Valmet for more information.
18. Never use a valve with enriched or pure oxygen if the valve is not explicitly designed and cleaned for oxygen. Selected materials and design have a major impact on the safety to operate the valve with oxygen.
19. Valves intended for use in or with explosive atmospheres must be equipped with a grounding device and marked according ATEX (or equivalent international standards).
20. Manual handles are available for specific butterfly valve sizes and maximum line pressures. Do not operate a valve with a handle or wrench outside the size and pressure limits stated in the IMO. High line pressure may create a large enough force to pull the handle from the operator's hands. Damage or personal injury may result.
25. Always check the position of the valve before starting maintenance work. Follow the Lock out /tag out (LOTO) rules at the site before starting any maintenance activity.
 - See IMO for the correct stem position.
 - Consider that the positioner may give the wrong signals.
26. Sealing materials (soft sealing parts) should be changed when the valve in maintenance. Always use original equipment manufacturers (OEM) spare parts to ensure proper performance of the repaired valve.
27. All pressure containing parts must be inspected visually for damage or corrosion. Damaged parts must be replaced.
28. Valve pressure retaining parts and all internals must be inspected for corrosion or erosion which may result in reduced wall thickness on pressure retaining parts. Damaged pressure retaining parts must be replaced with original equipment manufacturer's (OEM) replacement parts or repaired to factory specifications by an authorized Valmet service partner in order to maintain the warranty.
29. Do not use sharp tools, grinding machines, or files to work on functional surfaces such as sealing, seating or bearing surfaces as this can damage these surfaces.
30. Check the condition of sealing surfaces on the seats, trim (disc, ball, plug, etc.), body and body cap. Replace parts if there are significant wear, scratches, or damage.
31. Check the wear of bearings and bearing contact surfaces on the shaft and replace damaged parts if necessary.
32. Do not weld on pressure retaining parts without an ASME and PED qualified procedure and personnel.
33. Pressure retaining parts of valves in high temperature applications must be carefully examined for the effects of material creep and fatigue.
34. Make sure that the valve is positioned in the correct flow direction into the pipeline.
35. If the valves are marked to be suitable for explosive atmospheres, the correct function of the discharging device must be tested before returning to service.
36. Always work in a clean environment. Avoid getting particles inside the valve due to machining, grinding, or welding nearby.
37. Never store a valve in maintenance without flow port protection.
38. When pressure testing valve seats, never exceed the maximum operating pressure of the system or the maximum shut-off pressure marked on the valve identification plate.
39. Actuator mounting and unmounting:
 - Before installing the actuator on to the valve, be sure the actuator is properly indicating the valve position. Failure to assemble these to indicate correct valve position may result in damage or personal injury.
 - When installing or removing a linkage kit, best practice is to remove the entire linkage assembly, including couplings which may fall off the valve during lifting or when position changes.
 - Mounting sets have been designed to support the weight of the Valmet actuator and recommended accessories either as is or with additional actuator support. Use of the linkage to support additional equipment or additional weight such as people, ladders, etc. may result in equipment damage or personal injury.

Maintenance

21. Respect the safety warnings above!
22. Plan service and maintenance actions, that spare parts, lifting devices and service personnel is available.
23. Maintain the valve within the recommended minimum maintenance intervals or within the recommended maximum operating cycles.
24. Always make sure that the valve and the pipeline is depressurized before starting any kind of maintenance work at a valve.

40. The valve should be installed between flanges using appropriate gaskets and fasteners that are compatible with the application, and in compliance with applicable piping codes and standards. Center the gaskets carefully when fitting the valve between the flanges. Do not attempt to correct pipeline misalignment by means of the flange bolting.
41. Repairs on valves for special service like Oxygen, Chlorine, and Peroxide, have special requirements.
 - Parts must be cleaned appropriate to the service and protected from contamination prior to assembly.
 - Assembly areas and tools must be clean and dry to prevent contamination of the parts during assembly.
 - Test equipment must be clean and dry to prevent contamination during testing. This includes the test equipment internals that may allow particles or other contamination into the test medium during the test.
 - Lubrication shall be used only if specifically required in the instructions. Where lubrication is required, the lubricant must be approved for the service by the end user.

Valmet Flow Control Oy

Vanha Porvoontie 229, 01380 Vantaa, Finland.

flowcontrol@valmet.com

Tel. +358 10 417 5000.

www.valmet.com/flowcontrol

Subject to change without prior notice.

Neles, Neles Easyflow, Jamesbury, Stonel, Valvcon and Flowrox, and certain other trademarks, are either registered trademarks or trademarks of Valmet Oyj or its subsidiaries in the United States and/or in other countries.

