

# Neles™ high performance heavy duty scotch yoke actuator

## Series N1

Installation, maintenance and  
operating instructions

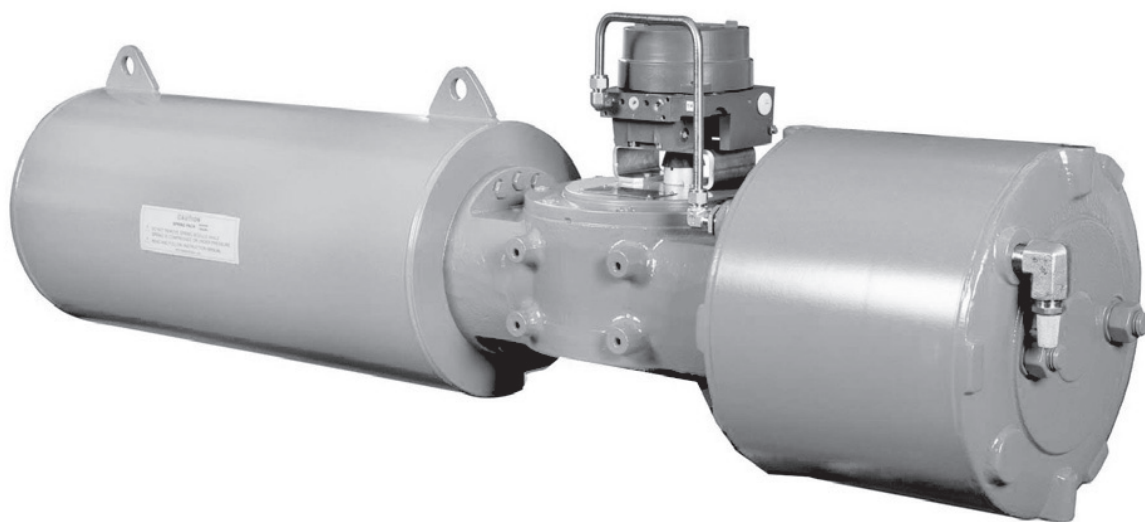

# Table of contents

<b>GENERAL</b>	<b>3</b>	<b>EXPLODED VIEWS AND PARTS LIST</b>	<b>28</b>
Scope of the manual	3	Double acting actuators N1_D00	28
Structure and operation	3	Double acting actuators N1_D00	29
Actuator markings	3	Single acting actuators N1_E_C	30
Specifications	4	Single acting actuators N1_E_C	31
Recycling and disposal	5		
Definitions	5	<b>DIMENSIONS AND WEIGHTS</b>	<b>32</b>
Safety precautions	5	Dimensions double acting	32
		Weights double acting	33
<b>TRANSPORTATION AND STORAGE</b>	<b>6</b>	Dimensions single acting	34
		Weights single acting	35
<b>MOUNTING AND DEMOUNTING</b>	<b>6</b>	Attachment dimensions	36
Actuator gas supply	6	<b>TYPE CODE</b>	<b>42</b>
Installation information	6		
Mounting the actuator on the valve	6		
Operating directions	7		
<b>MAINTENANCE</b>	<b>8</b>		
Maintenance general	8		
Maintenance precautions of the N1_E_C and N1_E_A actuator	9		
Actuator Disassembly	9		
Actuator Reassembly	16		
Stroke screw adjustment	23		
Field conversions	23		
Malfunctions	24		
Tools	24		
Tightening torque table	25		
Ordering spare parts	25		
Lifting tool table	25		
For ordering spare seal kit	26		
Recommended Lubricants	27		

## **READ THESE INSTRUCTIONS FIRST!**

These instructions provide information about safe handling and operation of the valve.

If you require additional assistance, please contact the manufacturer or manufacturer's representative.

## **SAVE THESE INSTRUCTIONS!**

Addresses and phone numbers are printed on the back cover.

# 1. GENERAL

## 1.1 Scope of the manual

This instruction manual contains important information regarding the installation, operation and maintenance of Neles N1 series actuators. Please read these instructions carefully and save them for future reference.

The manual can be changed or revised without any prior notice. Any changes in product's specification, structure, and/or any components may not result immediate revised version of the manual.

## 1.2 Structure and operation

The N1 series actuators are pneumatic quarter turn cylinder actuators designed for control and shut-off service. Design is modular and enables an ideal configuration of pneumatic, central block and spring modules. Ductile cast iron center body, fabricated carbon steel pneumatic module and spring module provides rugged actuator construction.

The spring provides the required safety function; the valve either opens or closes if the air supply is interrupted.

The mounting face dimensions of the N1 actuator comply with the ISO 5211 standard.

The N1\_E\_C is spring to close type actuator. The yoke of the actuator, when operated by the spring, rotates clockwise as seen from the pointer cover side. The piston then moves towards the frame side of the cylinder. The two keyways in the yoke are positioned at an angle of 90° to each other, making it possible to change the position of the actuator in relation to the valve, see Fig. 1.

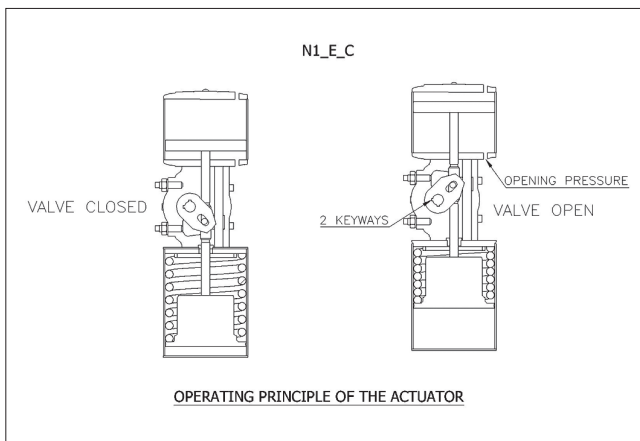

Fig. 1 Operating principle of the N1\_E\_C actuator

The N1\_E\_A is spring to open type actuator. The yoke of the actuator, operated by the spring, rotates counter clockwise as seen from the pointer cover side. The piston then moves towards the frame side of the cylinder. The two keyways in the secondary shaft (yoke) are positioned at an angle of 90° to each other, making it possible to change the position of the actuator in relation to the valve, see Fig. 2.

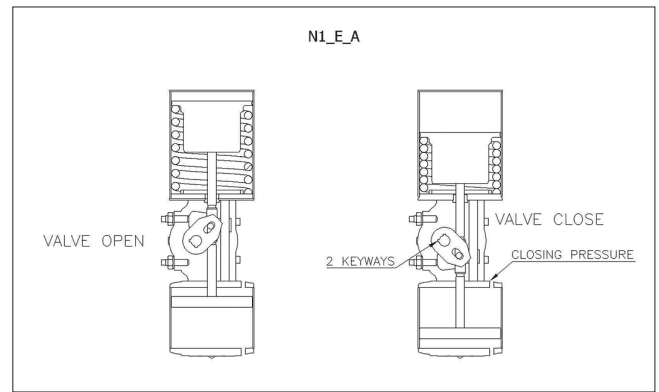

Fig. 2 Operating principle of the N1\_E\_A actuator

The N1\_D is a double acting actuator. The linkage mechanism converts linear motion (provided by an air supply and piston) to rotary motion. The yoke of the actuator rotates clockwise (close) when cylinder supply is in rear port and counter clockwise (open) when cylinder supply is in front port, see Fig. 3.

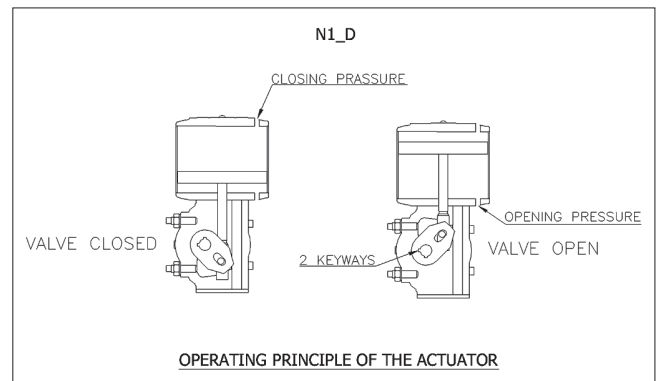

Fig. 3 Operating principle of the N1\_D actuator

## 1.3 Actuator markings

The actuator is provided with an identification plate, see Fig. 4.

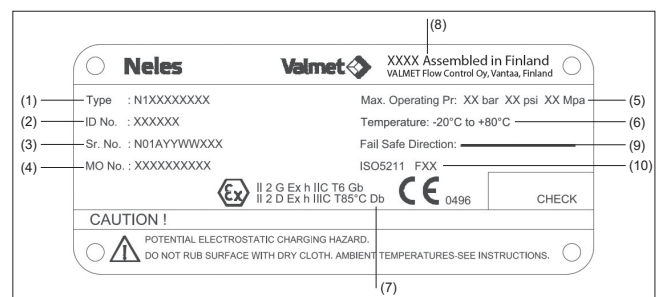
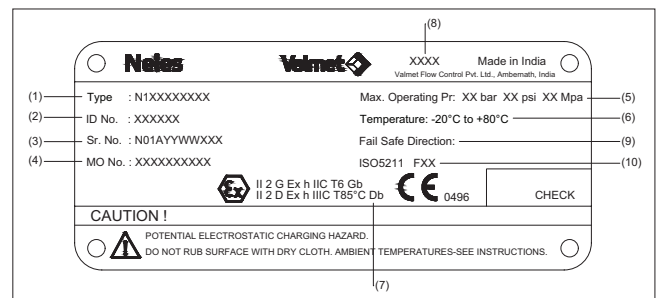

Fig. 4 Example ID plates

Identification plate markings are:

1. Type
2. ID Code
3. Sr No
4. MO No
5. Max operating pressure
6. Temperature range  
Standard design: -20° to 80° C  
High Temp. design: -20° to 125°C  
Arctic Temp. design: -55° to 80° C
7. Atex category & protective level
8. Manufacturing year
9. Fail safe direction
10. Mounting Face

## 1.4 Specifications

Protection class:	IP66M & IP67M
Ambient temperatures:	
Standard design	-20° to 80° C / -4° to 176° F
High temperature design	-20° to 125° C / -4° to 257° F
Arctic temperature design	-55° to 80° C / -67° to 176° F
Maximum Supply pressure:	Depends on model, See Table 3
Torque Output range	
Spring Return Model:	
- Spring Nominal:	21 Nm - 104174 Nm - Nm
- Air Brake @ 4 barg:	26 Nm - 148812 Nm
Double Acting Model:	
- Air Break @ 4 Barg:	71 Nm - 311333 Nm

Table 1 Stroke volume. dm<sup>3</sup> - Single -and Double acting for 90° stroke

Cyl. Diam (mm)	63	80	100	125	150	200	250	300	350	400	500	600	700	800	900	1000	1100	1200	1300
<b>Actuator</b>	<b>Stroke volume, dm<sup>3</sup></b>																		
N1X	0.2	0.3	0.4	0.7	-	-	-	-	-	-	-	-	-	-	-	-	-	-	-
N1A	-	-	0.9	1.4	2.0	3.6	5.7	8.2	11.2	-	-	-	-	-	-	-	-	-	-
N1B	-	-	-	-	-	-	7.4	10.6	14.4	18.8	-	-	-	-	-	-	-	-	-
N1C	-	-	-	-	-	-	-	13	17	23	35	-	-	-	-	-	-	-	-
N1D	-	-	-	-	-	-	-	-	21	27	42	61	83	-	-	-	-	-	-
N1E	-	-	-	-	-	-	-	-	-	-	51	74	100	131	165	-	-	-	-
N1G	-	-	-	-	-	-	-	-	-	-	-	90	123	161	204	-	-	-	-
N1H	-	-	-	-	-	-	-	-	-	-	-	-	152	199	252	312	-	-	-
N1J	-	-	-	-	-	-	-	-	-	-	-	-	200	261	331	408	-	-	-
N1M	-	-	-	-	-	-	-	-	-	-	-	-	-	-	-	526	637	758	889

Table 2 Maximum operating pressure

Cyl. Diam (mm)	63	80	100	125	150	200	250	300	350	400	500	600	700	800	900	1000	1100	1200	1300
<b>Actuator</b>	<b>maximum operating pressure, barg</b>																		
N1X	8.0	8.0	8.0	8.0	-	-	-	-	-	-	-	-	-	-	-	-	-	-	-
N1A	-	-	8.0	8.0	8.0	8.0	8.0	6.5	5.0	-	-	-	-	-	-	-	-	-	-
N1B	-	-	-	-	-	-	8.0	8.0	6.0	4.5	-	-	-	-	-	-	-	-	-
N1C	-	-	-	-	-	-	-	8.0	8.0	7.0	4.5	-	-	-	-	-	-	-	-
N1D	-	-	-	-	-	-	-	-	8.0	8.0	6.0	5.5	4.5	-	-	-	-	-	-
N1E	-	-	-	-	-	-	-	-	-	-	6.0	5.5	5.5	5.5	5	-	-	-	-
N1G	-	-	-	-	-	-	-	-	-	-	-	5.5	5.5	5.5	5.5	-	-	-	-
N1H	-	-	-	-	-	-	-	-	-	-	-	-	5.5	5.5	5.5	5.5	-	-	-
N1J	-	-	-	-	-	-	-	-	-	-	-	-	5.5	5.5	5.5	5.5	-	-	-
N1M	-	-	-	-	-	-	-	-	-	-	-	-	-	-	-	5.5	5.5	5.5	5.5

Note: Actuator output torques - consult factory.

## 1.5 Recycling and disposal

Most of the actuator parts can be recycled if sorted according to material. Most parts have material marking. A material list is supplied with the actuator. In addition, separate recycling and disposal instructions are available from the manufacturer. An actuator can also be returned to the manufacturer for recycling and disposal against a fee.

## 1.6 Definitions

The following definitions given here are used in this document:

### WARNING:

**If not observed, user incurs a high risk of severe damage to the product and/or fatal injury to personnel.**



### CAUTION:

**If not observed, user may incur damage to the product and/or injury to personnel.**

### NOTE:

Advisory and information comments provided to assist maintenance personnel to carry out maintenance procedures.

### WARNING FOR ATEX:

**If not observed, user incurs a high risk of severe damage to actuator and/or fatal injury to personnel.**



## 1.7 Safety precautions

### User Safety

#### CAUTION:

##### **Don't exceed the permitted values!**

Exceeding the permitted pressure value marked on the actuator may cause damage and lead to uncontrolled pressure release in the worst case. Damage to the equipment and personal injury may result.

#### CAUTION:

##### **Don't dismantle a pressurized actuator!**

Dismantling a pressurized actuator leads to uncontrolled pressure release. Shut off the supply pressure and release pressure from the cylinder before dismantling the actuator. Otherwise, personal injury and damage to equipment may result.

#### CAUTION:

**Follow the instructions given on the actuator warning plates!**

#### CAUTION:

**Before opening the cylinder fastening screws (11), release spring tension directed on actuator warning plate and in these instructions!**

#### CAUTION:

##### **Don't dismantle the spring module!**

Do not remove the spring module while the spring is compressed or under pressure.

#### CAUTION:

**Take the weight of the actuator or valve combination into account when handling it!**

**Lifting lugs on the actuator are meant only for lifting actuator and not complete valve assembly.**

Do not lift the valve combination from the actuator, positioner, limit switch or their piping. Lift the actuator as directed in Section 2, lifting ropes for a valve combination should be fastened around it. The weights are shown in Section 9. Dropping may result in personal injury or damage to the equipment.

#### CAUTION:

1. **Actuator should not be operated beyond MOP.**
2. **We recommend to use AFR and PRV for better functioning with safety.**
3. **Maintenance cycle should be followed for better working and safe operation.**



### ATEX/Ex Safety

#### CAUTION:

Ensure the general process and worker protection from static electricity in the facilities.

#### NOTIFICATION:

The actual surface temperature of actuator is depended on the process and ambient conditions. The protection from high or low temperature must be considered by the end user before put into service.

#### WARNING FOR ATEX:

While lifting actuator housing should not impact on the other light or rusty metal.



#### CAUTION:

Potential electrostatic charging hazard do not rub surface with dry cloth.

#### WARNING FOR ATEX:

**Inspect for paint damaged, to ensure continued corrosion protection. Actuator speed should not faster than specified in the following chart.**



#### WARNING:

Valve on which actuator is installed should be earthed properly to discharge static charge.

## 2. TRANSPORTATION AND STORAGE

Make sure that the actuator and associated equipment have not been damaged during transportation. Store the actuator carefully before installation, preferably indoors in a dry place. Do not take it to the installation site or remove the protective caps of ports for piping until just before installation.

Lift the actuator as shown in Fig. 5: in a horizontal position from the lifting lugs. Refer to Section 9 for weights.

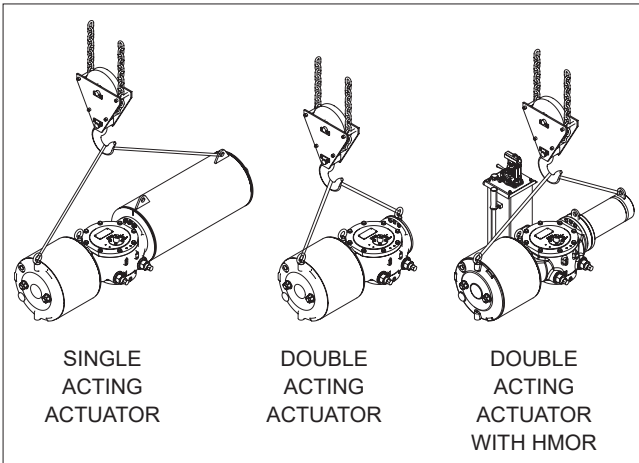

Fig. 5 Lifting the actuator

Upon receiving the product check the limit actuator and the accompanying devices for any damage that may have occurred during transport.

### WARNING:

**DO NOT USE THE DEVICE IF IT IS DAMAGED DURING TRANSPORTATION!**  
**IF THE DEVICE HAS SUFFERED DAMAGE DURING TRANSPORTATION DO NOT INSTALL AND USE IT. IN CASE OF NOTICING DAMAGE TO THE DEVICE UPON RECEIVING IT PLEASE CONTACT THE SUPPLIER.**



Store the actuator carefully. Storage indoors in a cool, dry place. Temperature limit for the storing is from 4 °C to 40 °C. The actuator should be left in its original packing until it is required for the use. Do not remove protective plugs until installing the actuator.

## 3. MOUNTING AND DEMOUNTING

### 3.1 Actuator gas supply

Dry compressed air, nitrogen or natural gas (sweet) can be used as supply medium, no oil spraying is needed. The air supply connections are presented in the dimensional drawings in Chapter 6. The maximum supply pressure is depending on the selected model.

### 3.2 Installation information

Before installation please, take care of the safety precautions mentioned in the Section 1.7.

Ensure that the actuator will not be exposed to pressure in excess to the maximum rating as indicated on the actuator nameplate or technical documents.

Ensure that throughout the installation that there are no leaks of the supply media.

The maximum operating temperature for the actuator depends on individual build of actuator. Refer nameplate for operating temperature range.

Ensure that the maximum operating temperature as indicated on the nameplate is not exceeded during operation, transportation or storage of the actuator.

The environment and surrounding should not affect or limit the operational safety of the product.

Ensure the product is protected against impact, vibration or any kind of movement during operation, transportation and storage.

Product should not be installed in hazardous area that is not compatible with the gas group and temperate class indicated on the nameplate.

N1 series actuators can be mounted on valve in any desired position. However, it is recommended to align the centerline of the pneumatic cylinder module along the pipeline.

Ensure proper tightening of fasteners and mounting accessories to avoid loosening during operation.

All the tubing, fitting and actuation media should be free from contamination and filtered to the desired level. Quality of media should be as per ISO 8573-1 [5:3:4]. For additional information consult Neles.

Ensure proper adjustments of the stopper bolt to desired opening and closing of the valve.

Once proper installation is done, check for smooth continuous operation. If undesired operation occurs, check for correct pressure and volume flow.

### NOTE:

Flow may be restricted by underrsize tubing or fitting. These may throttle the flow resulting in reduce pressure or volume causing intermittent or undesired movement.

### 3.3 Mounting the actuator on the valve

### CAUTION:

**Be aware of the cutting movement of the valve!**

Install the actuator so that the shaft of the valve or any other device to be actuated goes into the shaft bore of the

actuator. If the bore is larger than the shaft diameter, use a keyed shaft adapter, sleeve or bushing. There are two key way slots in the shaft bore of the actuator at an angle of 90°. These allow the installation position of the actuator to be changed in relation to the valve. Neles valves have a bevel at the end of their shafts to facilitate installation.

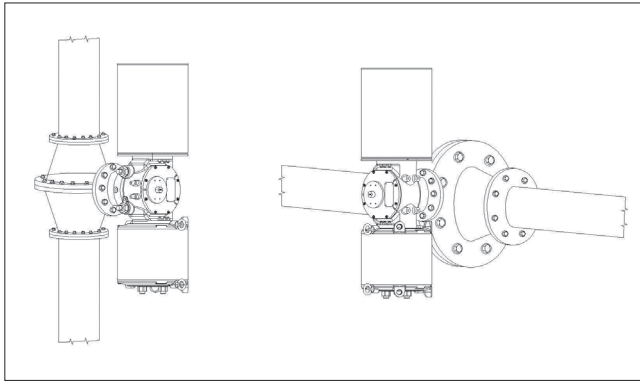

Fig. 6 Ways to install the actuator

The installation position can be selected freely, but Neles recommends installation of spring return version with the pneumatic cylinder pointing towards the ground. Double acting version can be installed at any position. The actuator is thus best protected against damage due to supply air impurities or water. When the installation position of the actuator is altered, the arrow indicating the operating direction must be turned to correspond with the actual operation of the valve.

When necessary, lubricate the actuator bore and collar with grease or anti-corrosive agent to prevent it from jamming due to rust.

The actuator must not be allowed to come in contact with the pipework, because the vibrations may damage it or cause unsatisfactory operation.

If the actuator is used with devices other than Neles valves, any additional parts attached to the actuator must be properly protected.

### 3.4 Operating directions

**NOTE:**

Separate instructions are available for adjusting the close limit of metal-seated butterfly valves. Refer to the installation, operating and maintenance instructions of the valve.

#### N1\_E\_C actuator spring -to-close direction

Install the actuator on the valve with the spring return position (fail safe) and the valve in the closed position, see Fig. 5. The cylinder must be de-pressurized and the air ports open. Adjust the closed-position setting using the stop screw (52a) on center block. The open-position setting is adjusted with stop screw (52b) on the center block while the actuator is pressurized, and the piston is at the rear end of the cylinder.

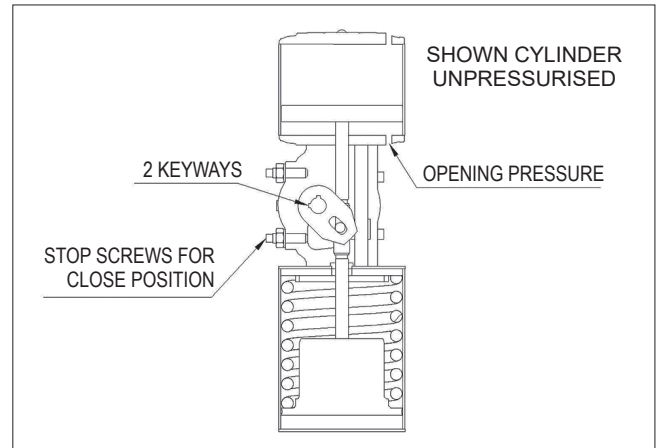

Fig. 7 N1\_E\_C actuator

#### N1\_E\_A actuator spring -to-open direction

Install the actuator on the valve with the spring return position (fail safe) and the valve in the open position, see Fig. 6. The cylinder must be de-pressurized and the air ports open. Adjust the open-position setting using the stop screw (42b) on center block. The closed-position setting is adjusted with stop screw (42a) on the center block while the actuator is pressurized and the piston is at the rear end of the cylinder.

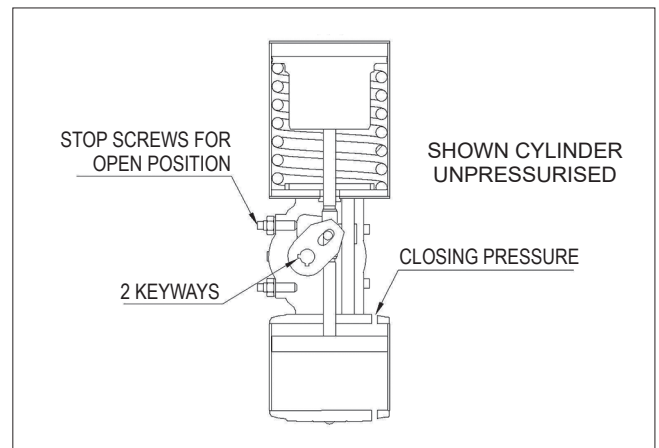

Fig. 8 N1\_E\_A actuator

### Demounting the actuator from the valve

**CAUTION:**

**Depressurize the actuator before starting demounting!**

The actuator must be de-pressurized and the supply air disconnected. Unscrew the actuator-side screws of the bracket and pull the actuator off the valve shaft. This is best done by lifting the actuator from lifting lugs by crane. Note the mutual positioning of the valve and the actuator to ensure correct functioning after reassembly.

# 4. MAINTENANCE

## 4.1 Maintenance general

**CAUTION:**  
Observe the safety precautions mentioned in Section 1.7 before maintenance!

Although Neles actuators are designed to work under severe conditions, proper preventative maintenance can significantly help to prevent unplanned downtime and in real terms reduce the total cost of ownership. Neles recommends inspecting the actuators at least every five (5) years. The inspection and maintenance interval depend on the actual application and process condition. The inspection and maintenance intervals can be specified together with your local Neles experts.

During this periodic inspection the parts detailed in the Spare Part Set should be replaced. Time in storage should be included in the inspection interval.

If maintenance assistance is required, please contact your local Neles office. The part numbers in parentheses () in the text refer to the exploded view and to the parts list in Section 5, unless otherwise stated.

This procedure is applicable with the understanding that all pneumatic pressure has been removed from the actuator.

Remove all piping and mounted accessories that will interfere with the module that are to be worked on.

When removing seals from seal grooves; use a commercial seal removing tool or a small screwdriver with sharp corners rounded off. Use a non-hardening thread sealant on all pipe threads.

**CAUTION:**  
Apply the thread sealant as per the manufacturer's instructions.

All parts should be thoroughly inspected for excessive wear, stress cracking and pitting. Attention should be directed to threads, sealing surfaces and areas that are subjected to sliding and rotating motion.

Actuator parts that reflect any of the above listed characteristics should be replaced with new parts.

Neles recommends that disassembly of the actuator modules should be done in a clean area on a workbench.

After reassembly, the actuator needs to be stroke for several times to ensure the desired function and safety.

If you remove the stop screw, adjust the limits after lubrication or grease filling!

Before doing maintenance, check actuator for leakage at inlet, outlet and cover.

**For single acting actuator if port A is connected then check air leakage from exhaust port.**

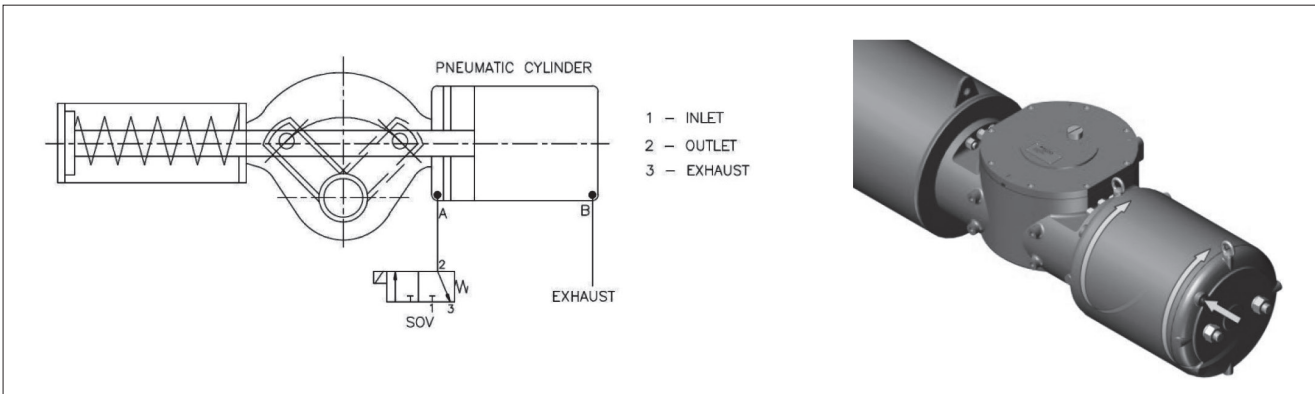

**For double acting actuator if port B is connected then check air leakage from exhaust port.**

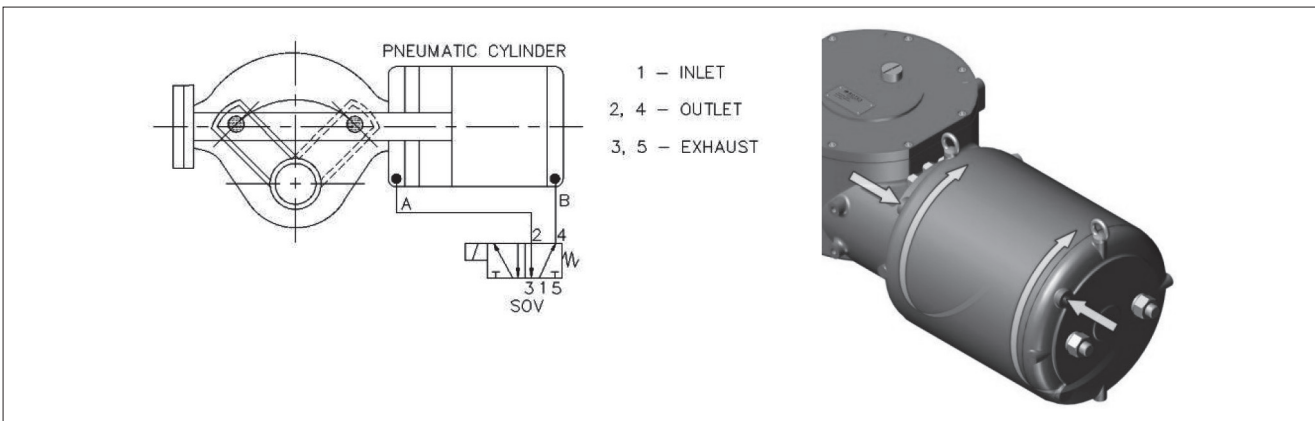

**NOTE:**

In order to ensure safe and effective operation, always use original spare parts to make sure that the actuator functions as intended.

**NOTE:**

When sending goods to the manufacturer for repair, do not disassemble them.

**NOTE:**

For safety reasons, replace bolting if the threads are damaged, have been heated, stretched or corroded.

## 4.2 Maintenance precautions of the N1\_E\_C and N1\_E\_A actuator

**CAUTION:**

**Don't dismantle a pressurized actuator!**

**CAUTION:**

**To release spring tension, the spring direction stop screw at the central block must be removed before the cylinder fastening screws are opened!**

**CAUTION:**

**Don't dismantle the spring package!**

The spring package within the cylinder is preloaded. Never open or dismantle the spring package. The spring module is always delivered as a pre-assembled package.

The spring module has a warning sticker. When servicing the unit, check that the sticker is in place and legible. See Fig. 9. Also check that the spring module has the arrow sticker indicating the spring operating direction.

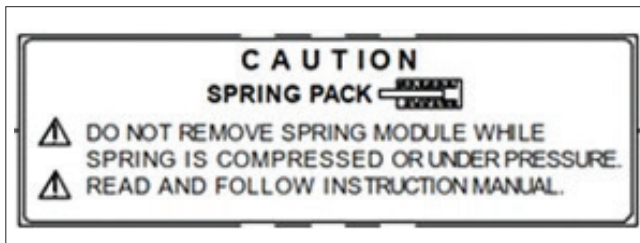
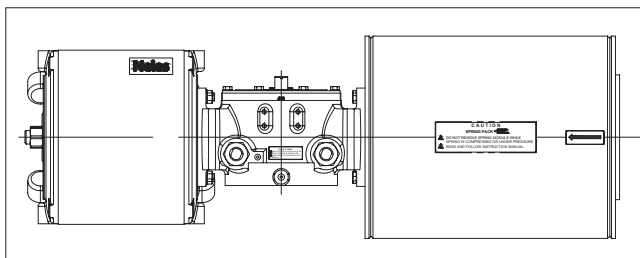

Fig. 9 Warning plate of the N1\_E\_C and N1\_E\_A actuator



## 4.3 Actuator Disassembly

### 4.3.1 General Disassembly

**WARNING:**

It is possible, that the actuator may contain a dangerous gas and/or liquids. Ensure that all proper measures have been taken to prevent exposure or release of these types of contaminants before commencing any work.



Actuator disassembly is referred to either completely disassemble the entire actuator or can be used to disassemble individual modules as needed (pneumatic cylinder or spring module).

When the spring module is to be removed it should be removed from the central block module prior to the Pneumatic cylinder module removal or disassembly. Then rotate actuator by 45° for Pneumatic cylinder assembly removal or disassembly.

To ensure correct reassembly, mark or tag mating surfaces.

Actuator central block base should be rigidly mounted before disassembly of any component.

#### 4.3.1.1 Spring module removal:

**WARNING:**

Do not remove spring module while spring is compressed.



**NOTE:**

Before proceeding with spring module disassembly, the setting of stop screws should be checked and setting recorded before stop screws are loosened or removed.

**Step 1.** Apply pneumatic pressure to front cover (3) to compress the spring enough to move the yoke off the stop screw of spring module side of the central block module.

**Step 2.** Loosen the screw nut (53) located on the stop screw that is closest to or next to Spring Module.

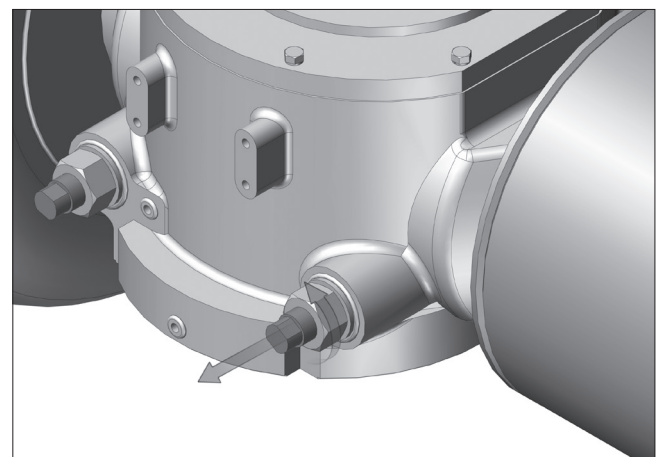

**Step 3.** Unscrew stop screw (52) that is closest to or next to Spring Module (unscrew or back out until the load is removed from the stop screw).

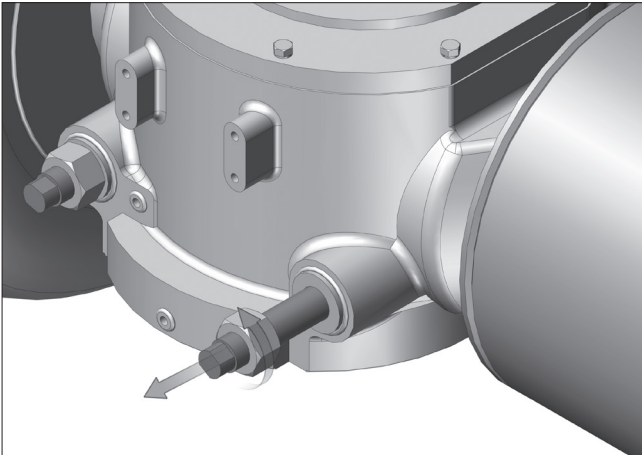

**Step 4.** Remove pneumatic pressure from inlet port of front cover (3).

**CAUTION:**

Due to the weight and size of spring module assembly, heavy duty support equipment will be required when removing module from actuator assembly.



**Step 5.** Spring module preload must be removed before spring module is removed from actuator assembly. To remove spring module preload, apply pneumatic pressure to rear cover (10) to move the spring module connecting rod (27).

**CAUTION:**

Maximum pressure to be applied in the above step is 1 barg (1 kg/cm<sup>2</sup>).  
If pneumatic pressure is not available to apply, use special Neles spanner.



**Step 6.** Unscrew bolts (60) of rear side end cap (28) and remove end cap.

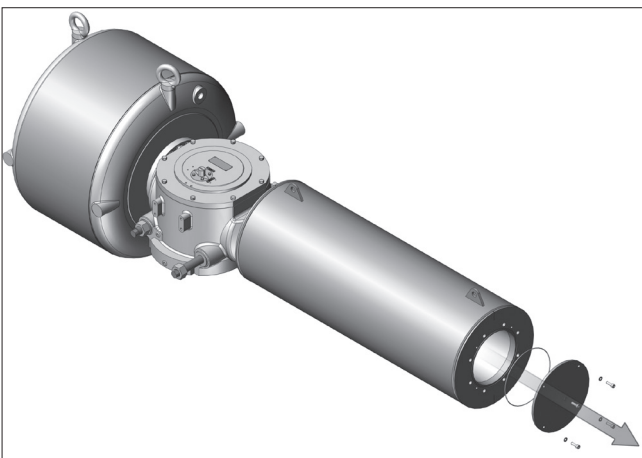

**Step 7.** Unscrew & remove hexagon jam nuts (59) of connecting rod (27) through an open end.

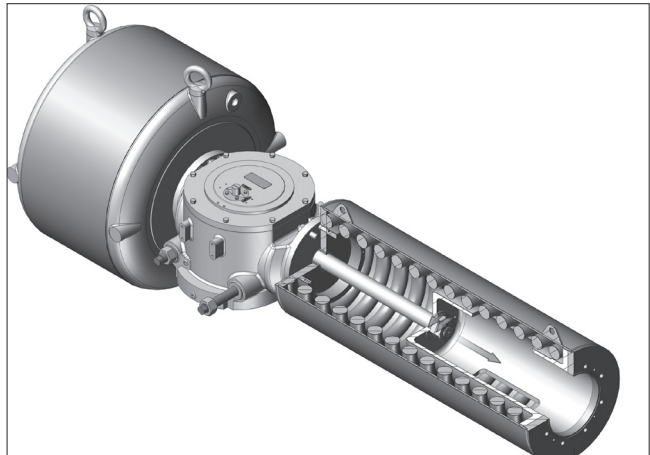

**Step 8.** Remove hex cap screw / stud (11) & nut (47) with lock washer (46) from central block. Remove spring module from actuator assembly, use lifting lugs provided on spring module assembly for lifting.

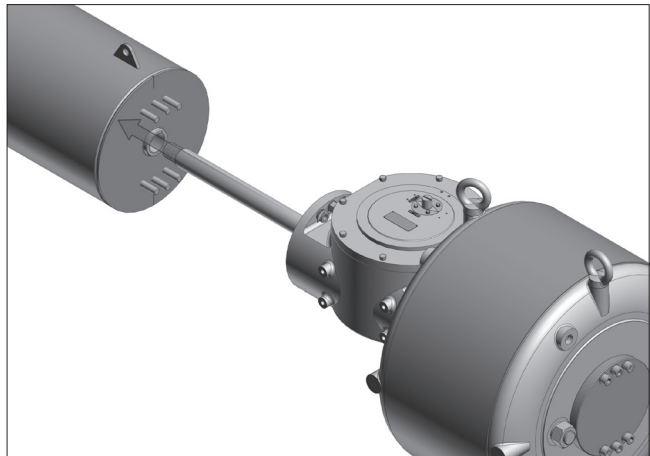

**WARNING:**

Under no circumstances should the spring module assembly be cut apart, as the spring is preloaded and spring module is welded assembly.



**Step 9.** Un-screw and remove hex. Soc. Head cap screw (55) from top cover (12) of central block module. Fitment between top cover (12) and central block (1) is tight, use screwdriver as crowbar and put it in slot provided on central block cover to lift the cover.

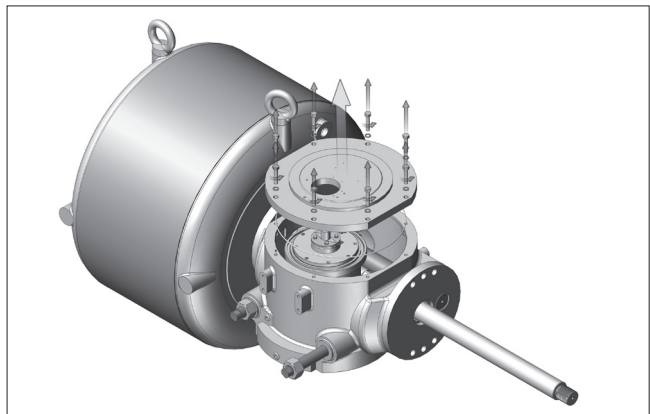

**CAUTION:**

Do not damage O-ring or O-ring groove while removing top cover (12).



**Step 10.** Unscrew & remove connecting rod (27) from carrier (15).

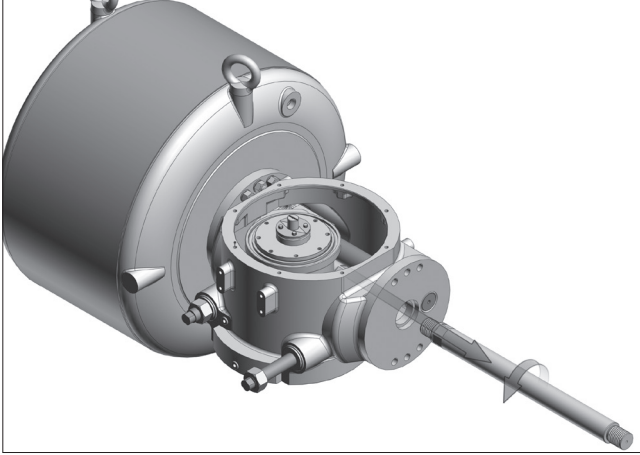

**Step 3.** Through an open end of the rear cover loose the lock nut (157) of piston rod with the help of fixture.

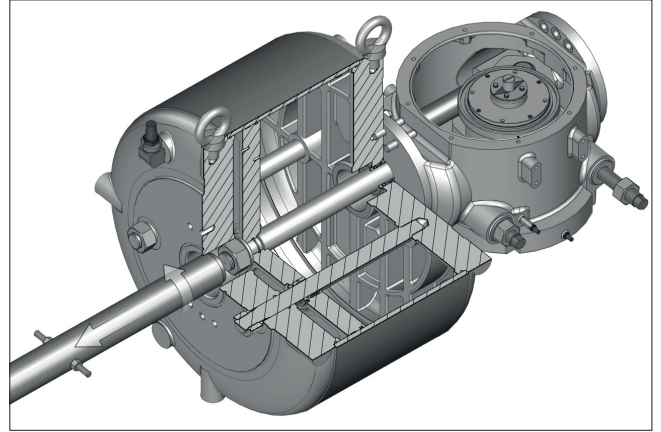

**Step 4.** Apply pneumatic pressure to rear cover (10) to rotate actuator by 45°. Unscrew & remove piston rod (9) from the carrier (15).

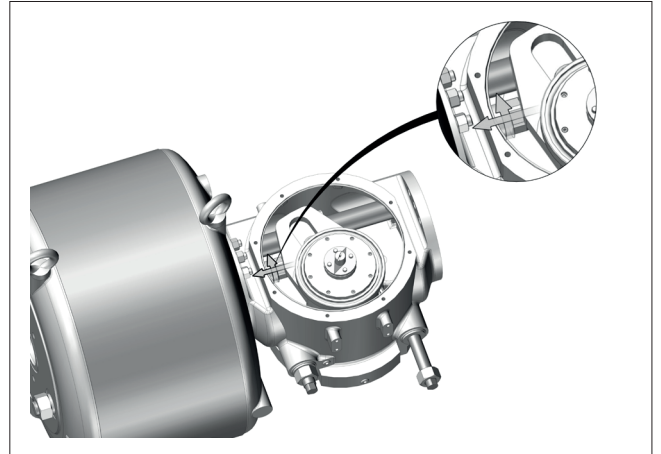

#### 4.3.1.2 Pneumatic Cylinder Module Removal:

**CAUTION:**

Spring module should be removed before starting pneumatic cylinder module removal procedure. Also follow step 9 from section 4.6.1.1 for double acting actuator.



**NOTE:**

Step 1, 2 & 3 are not applicable for cyl. Dia. 63 to 150.

**Step 1.** Unscrew bolts (159) of rear plug (156) and remove rear plug along with O-ring (163).

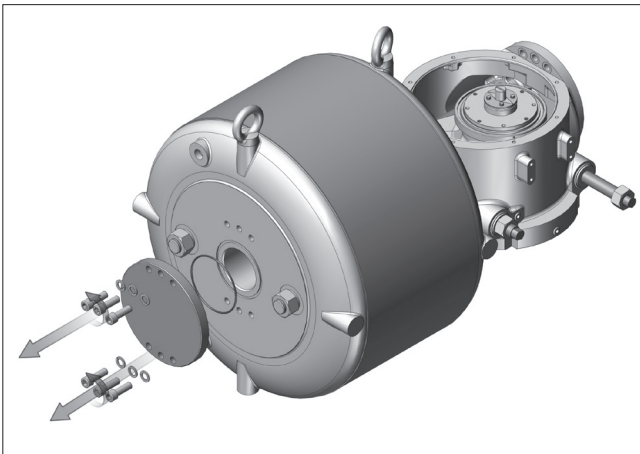

**Step 2.** Ensure piston is at the rear cover side. If required, apply pneumatic pressure to front cover to move the piston towards rear side.

**CAUTION:**

Maximum pressure to be applied in the above step is 1 barg (1 kg/cm<sup>2</sup>).



**Step 5.** Remove 6 studs/ hex cap screw (11) & nut (47) with lock washer (46) from central block (1).

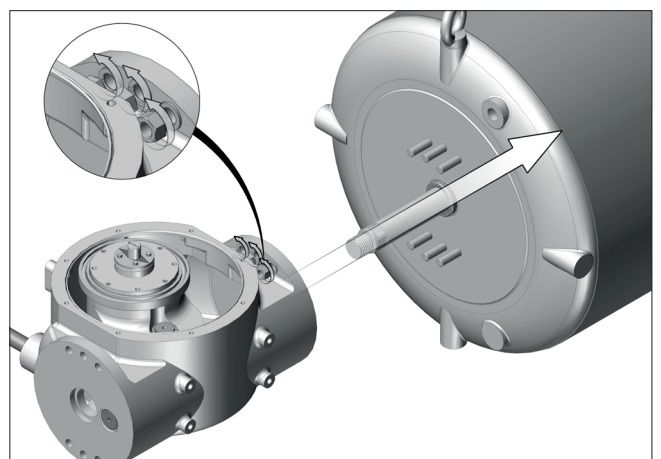

**NOTE:**

When removing cylinder module from actuator assembly, be careful to lose o-ring seals.

**Step 6.** Remove pneumatic cylinder module from actuator assembly. Use eye bolts for lifting the module.

4.3.1.3 A) Pneumatic Cylinder Module Disassembly:  
(For cylinder dia. 200 to 1300)

**Step 1.** Remove the pneumatic cylinder module from central block. Review the section 4.6.1.2 to for removal of pneumatic cylinder module.

**Step 2.** Remove two tie rod hex nuts (50) with spring washer (49) from outboard side of rear cover (10).

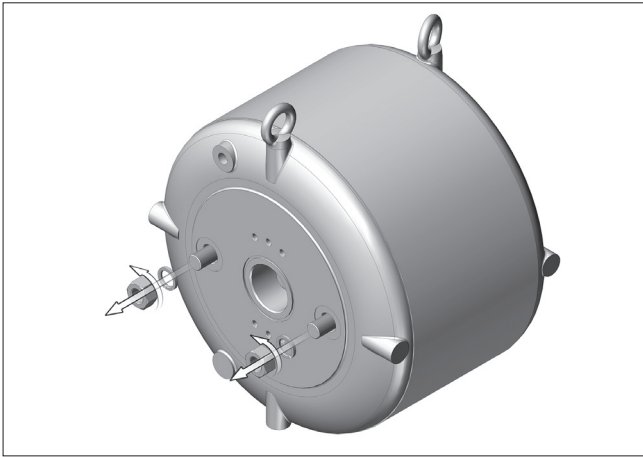

**Step 3.** The fit between cylinder tube (2) and rear cover (10) is very tight. Use screwdriver as crowbar to remove rear cover (10) from cylinder tube (2), remove rear cover from cylinder tube.

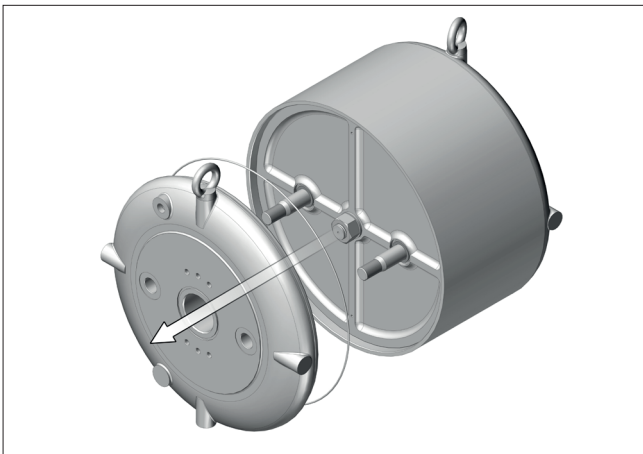

**CAUTION:**

Do not damage O-ring groove when removing rear cover from cylinder tube.



**NOTE:**

Use cover taping hole for lifting.

**Step 4.** When removing cylinder tube (2) off piston (6), tilt respect to actuator centerline, remove cylinder tube from piston (6) and front cover (3).

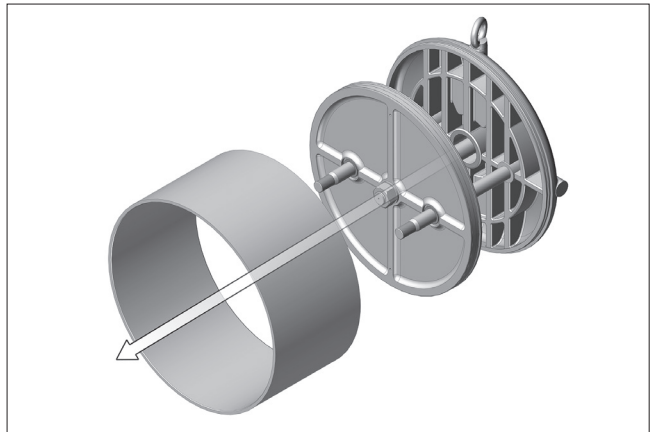

**Step 5.** Remove piston assembly (6) alongwith piston rod from tie rod & front cover.

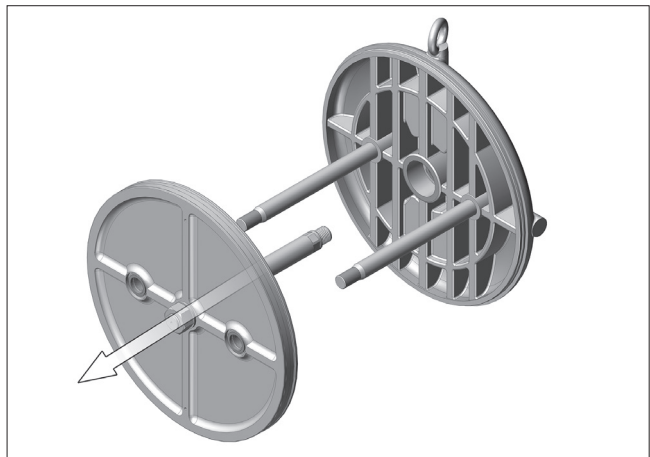

**CAUTION:**

Do not damage seals of guide bushing while removing piston assembly (6).



**NOTE:**

Use piston taping hole for lifting.

**Step 6.** Unscrew lock nut (157) and remove piston rod (9) from the piston (6). Remove o-ring, quad seal & piston strip from the piston.

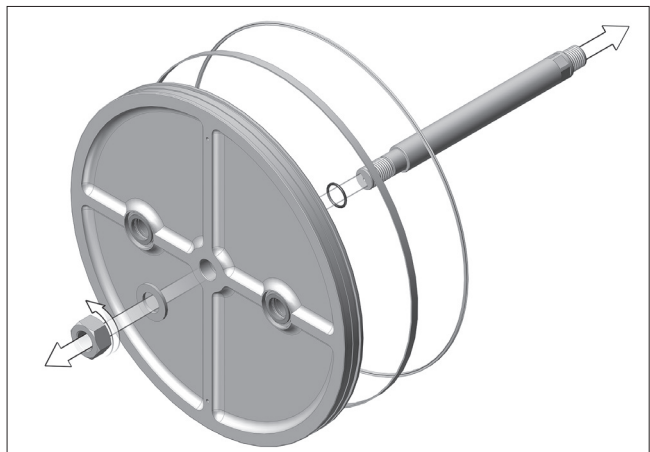

**Step 7.** Remove retaining ring (62) of guide bush. Remove guide bush & its seals.

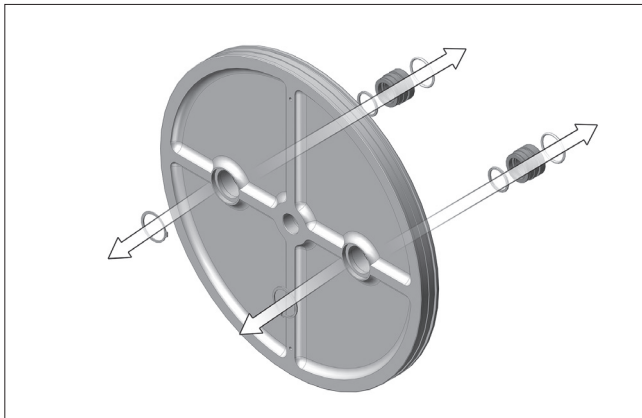

**Step 8.** Remove tie rod (8) from front cover. To remove tie rod, use two lock nuts assemble them on tie rod and tight them with each other then turn one lock nut to remove tie rod.

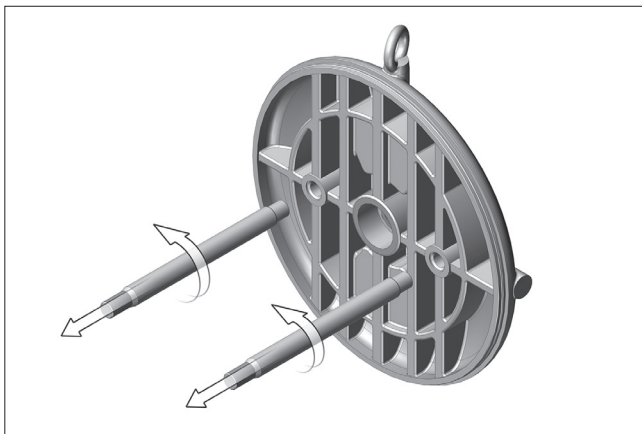

**Step 9.** Remove retaining ring (45). Remove bearing bush (5) & all seals.

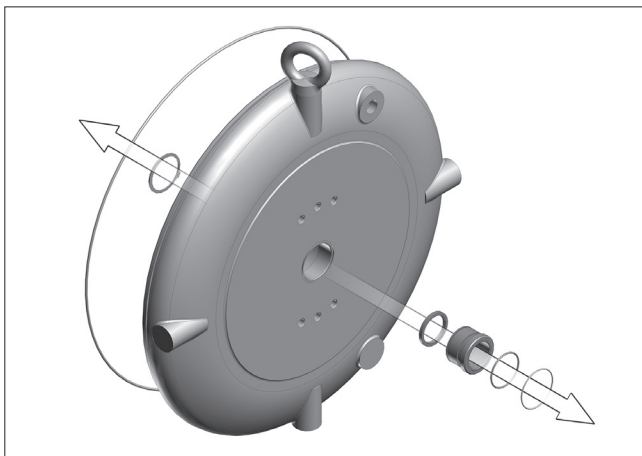

**CAUTION:**  
Do not damage seals of bearing bush (5) while removing it.



### 4.3.1.3 B) Pneumatic Cylinder Module Disassembly: (For cylinder dia. 063 to 150)

**Step 1.** Remove the pneumatic cylinder module from central block. Review the section 4.6.1.2 to for removal of pneumatic cylinder module.

**Step 2.** The cylinder tube (2) and rear cover (10) are fitted together by threaded joint. Rotate the rear cover counterclockwise to remove from the tube. Use tap holes provided on cover for rotation purpose. Remove the rear cover from the cylinder tube.

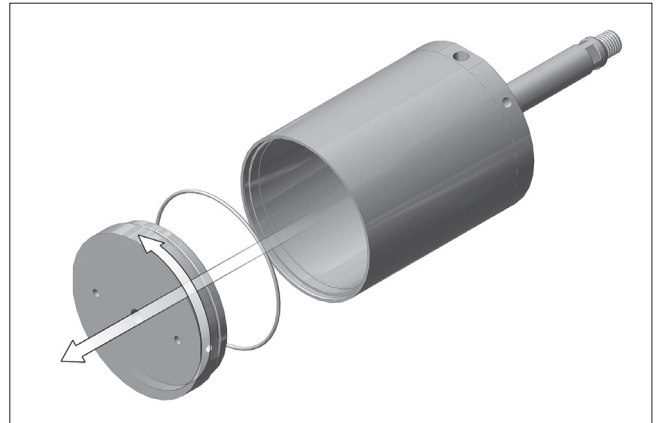

**CAUTION:**  
Do not damage O-ring groove when removing rear cover from cylinder tube.



**Step 3.** Remove piston assembly (6) alongwith piston rod (9) from cylinder tube.

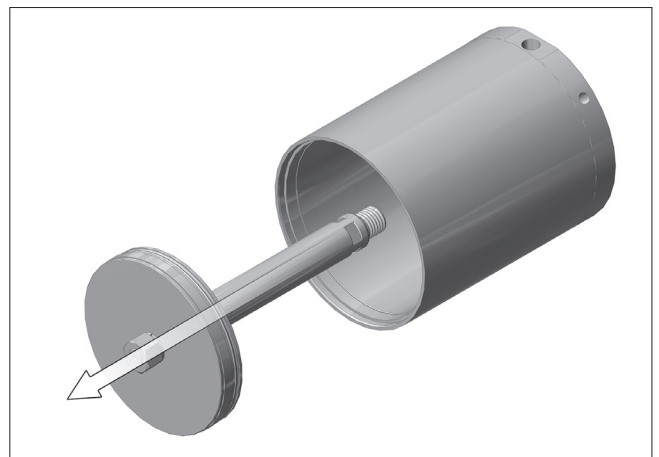

**Step 4.** Unscrew & remove piston rod lock nut (157) and spring washer (158). Remove piston rod from the piston.

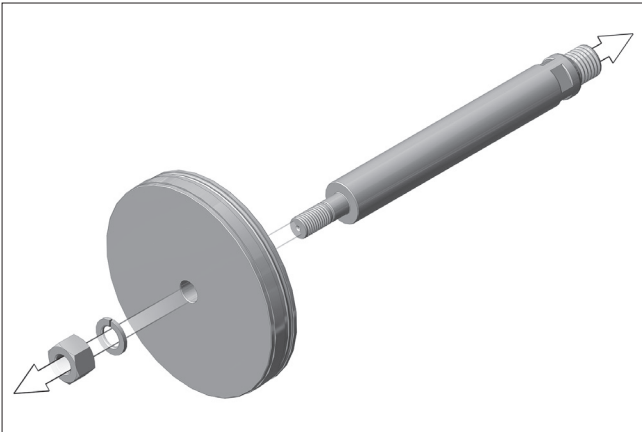

**Step 5.** Remove piston rod o-ring (162), quad seal & piston strip from the piston.

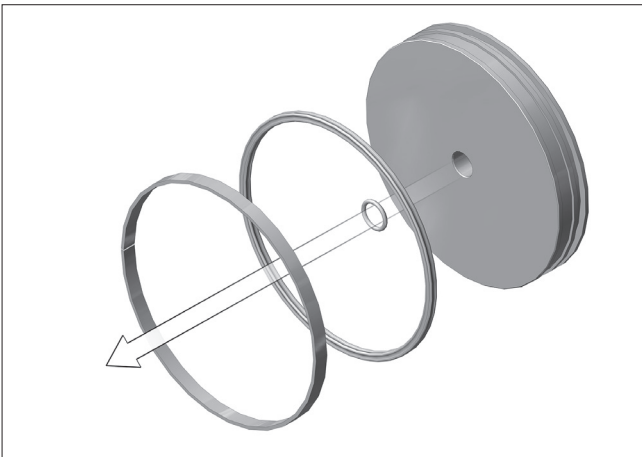

**Step 6.** The cylinder tube (2) and front cover (10) are fitted together by threaded joint. Rotate the front cover counterclockwise to remove from the cylinder tube. Use tap holes provided on cover for rotation purpose. Remove the front cover from the cylinder tube.

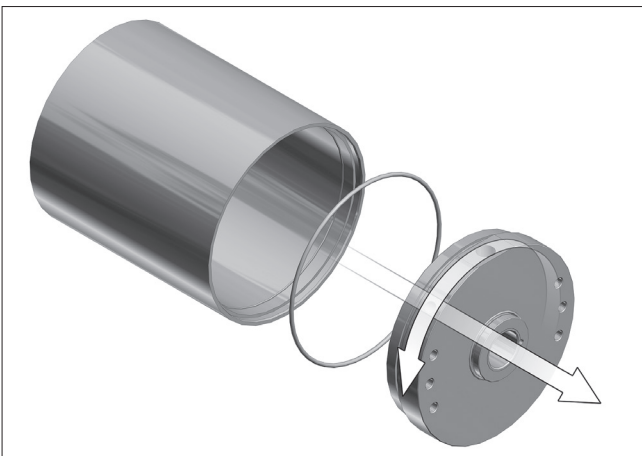

**CAUTION:**

Do not damage O-ring groove when removing front cover from cylinder tube.



**Step 7.** Remove retaining ring (45). Remove bearing bush (5), rod seal & o-ring. (Insert image XPCD-7)

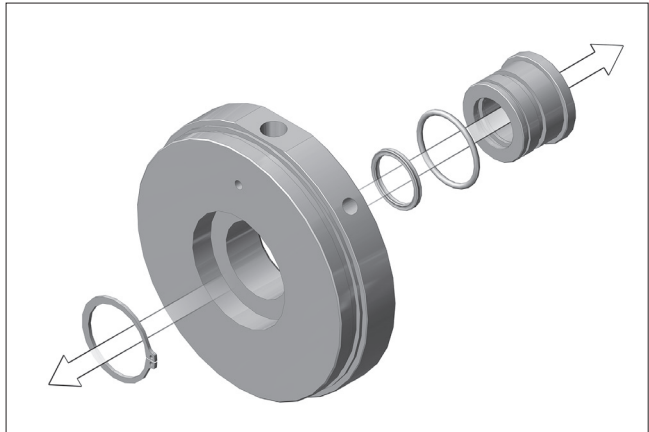

**CAUTION:**

Do not damage seals of bearing bush (5) while removing it.



**4.3.1.4 Central Block Module Disassembly:**

**CAUTION:**

Spring module and pneumatic cylinder module should be removed before starting central block module removal procedure. (Review section 4.6.1.1 for Spring module removal and 4.6.1.2 & 4.6.1.3 for Pneumatic Module removal)

The setting of stroke adjustment screw (52) should be checked and recorded before stroke adjustment screws are loosen or removed.



**NOTE:**

Stroke adjustment screw will be removed later in this procedure.

This procedure considers top cover (12) was removed while disassembling the pneumatic cylinder module and spring module.

**Step 1.** Unscrew and remove hex. Soc. Head cap screw (57) from yoke inserts (19) and remove yoke insert (19) from yoke (13).

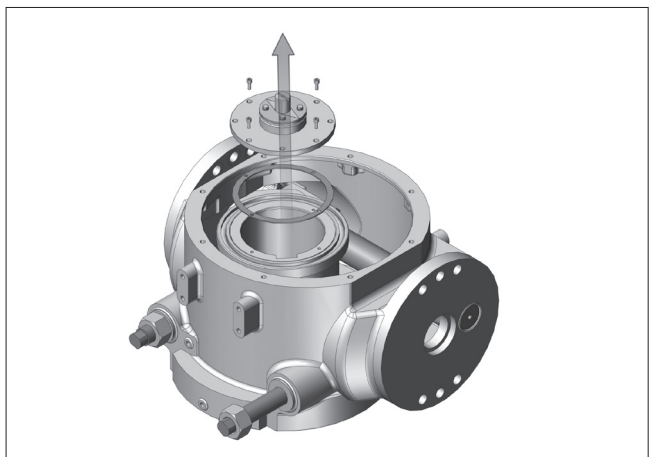

**Step 2.** Remove yoke top bearing (56) from yoke (13).

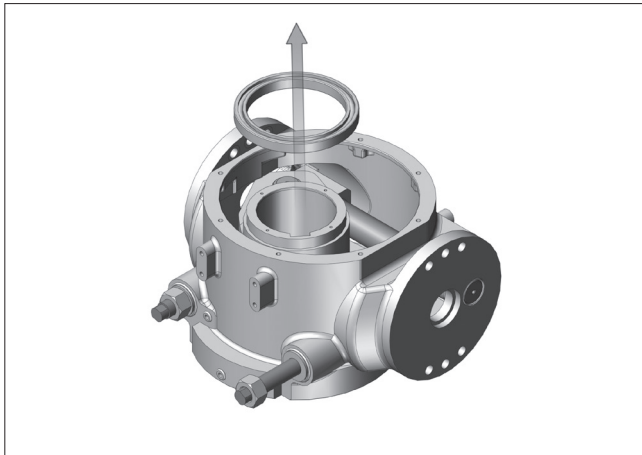

**Step 3.** Remove guide rod (14) from central block housing (1).

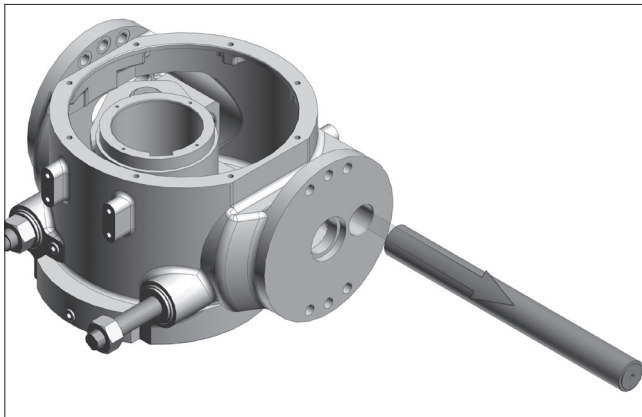

**NOTE:**

Taping provided on guide rod to pull out the guide rod from central block housing. When removing guide rod from actuator assembly, be careful to lose O-ring seals.

**Step 4.** Remove yoke (13) with carrier assembly (15) from central block housing.



**Step 5.** Put the yoke assembly on clean and dry place and remove top retaining ring (61), top roller (17) & yoke pin washer (18) from yoke pin (16).

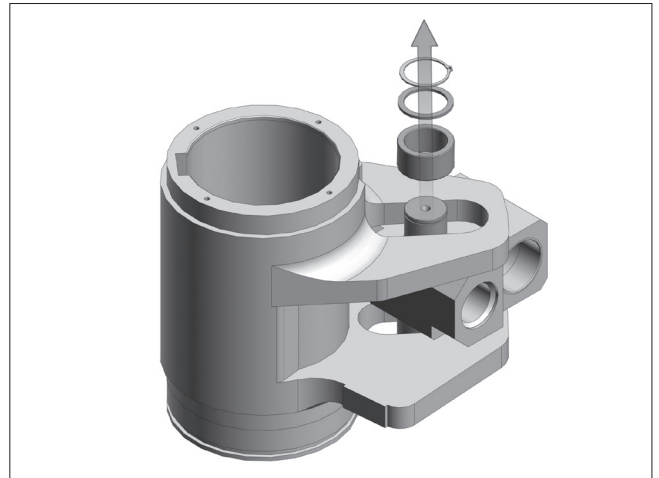

**Step 6.** Remove yoke pin (16) from bottom side of carrier (15) and then remove carrier (15) from yoke (13).

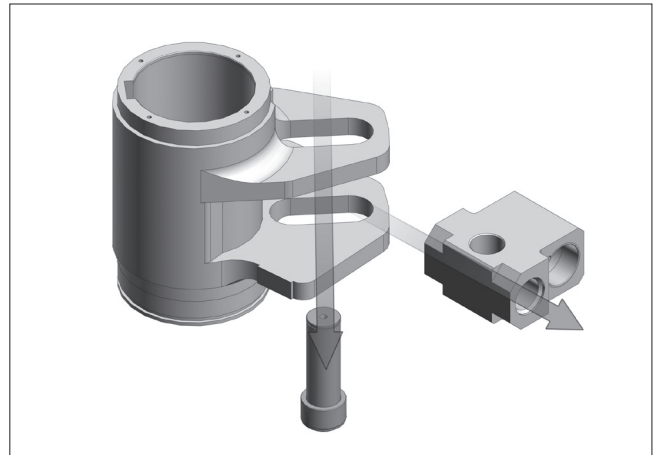

**Step 7.** Remove bottom side bearing (56) of yoke (13) from central block housing (1).

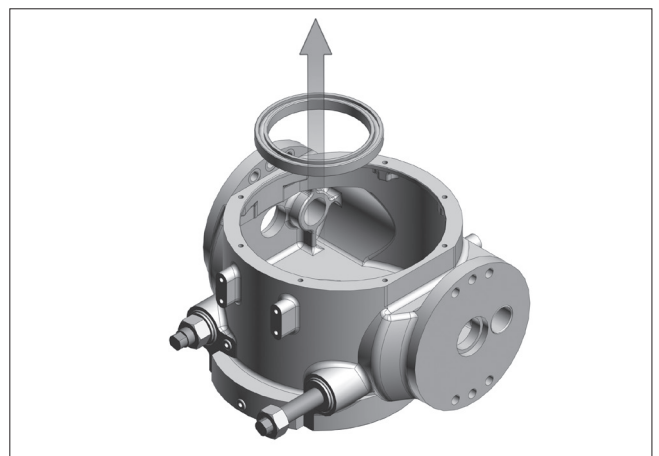

**Step 8.** Unscrew and remove two stroke adjustment screws (52), nuts (53), washer (58) & o-ring (34) from central block (1).

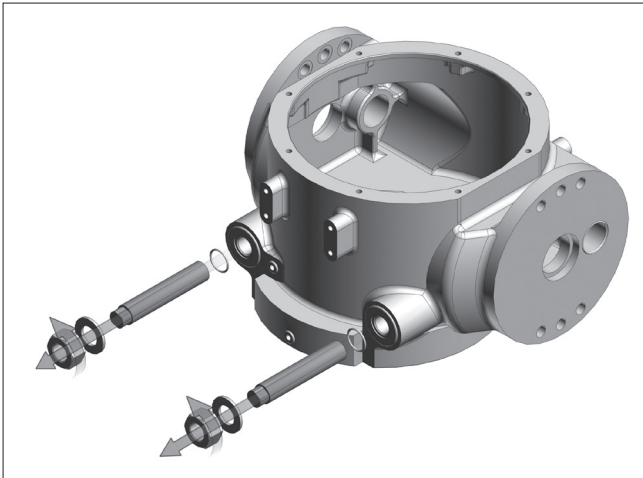

#### 4.4.1.1 Central block module reassembly

**Step 1.** Install two stroke adjustment screws (52), nuts (53), washer (58) & o-ring (34) to the central block (1).

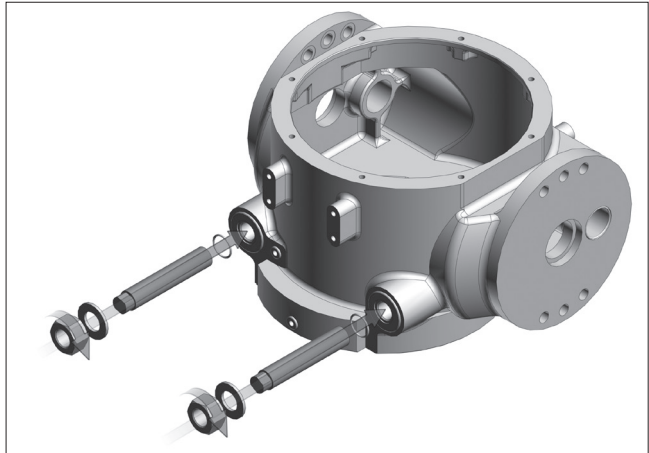

## 4.4 Actuator Reassembly

### 4.4.1 General reassembly

**CAUTION:**

Only new seals, which are still within the seal's expectant shelf life, should be installed into the actuator being refurbished.



Remove and discard all old seals and gaskets.

Parts should be cleaned to remove all dirt and other foreign material prior to inspection.

Parts should be thoroughly inspected for excessive wear, stress cracking, galling, and pitting. Attention should be directed to threads, sealing surfaces and areas that will be subjected to sliding or rotating motion. Sealing surfaces of the cylinder, tie rods and piston rod must be free of deep scratches, pitting, corrosion and blistering or flaking coating.

**CAUTION:**

Actuator parts that reflect any of the above listed characteristics should be replaced with new parts.



Before installation apply film of lubricant on all moving parts. Apply film of lubricant on all seals before installing into seal grooves.

**NOTE:**

Parts and seals used in the actuator will be assembled using lubricant as identified in unit 1 section 1.8.

**Step 2.** Install bottom yoke bearing (56) in central block housing (1). Apply grease on bearing seat on central block housing for ease of assembly.

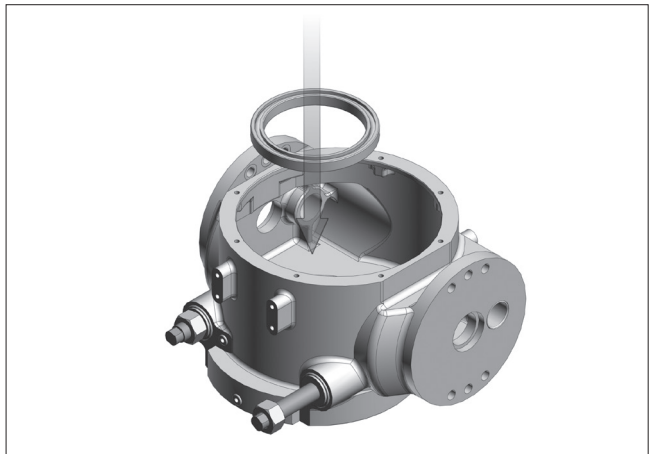

**Step 3.** Install carrier (15) in yoke (13) then insert yoke pin assembly (16) with roller (17) and washer (18) from bottom side for carrier. Lubricate yoke pin (16), roller (17) and carrier (15).

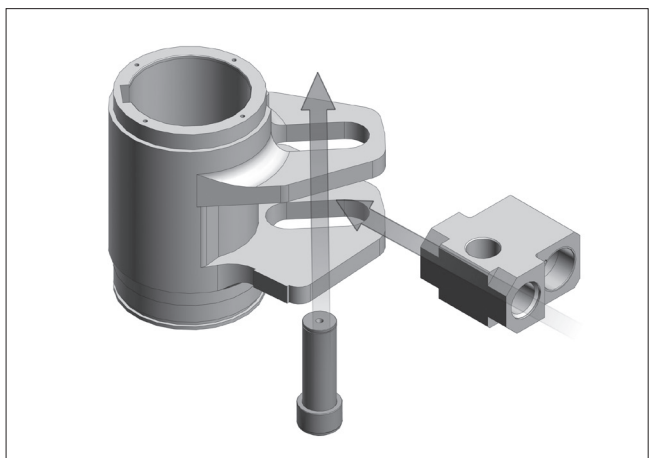

**Step 4.** Install hex. Head cap screw in carrier to locate the yoke pin at the center of carrier.

**Step 5.** Install top side roller (17), washer (18) and retaining ring (61) on yoke pin (16).

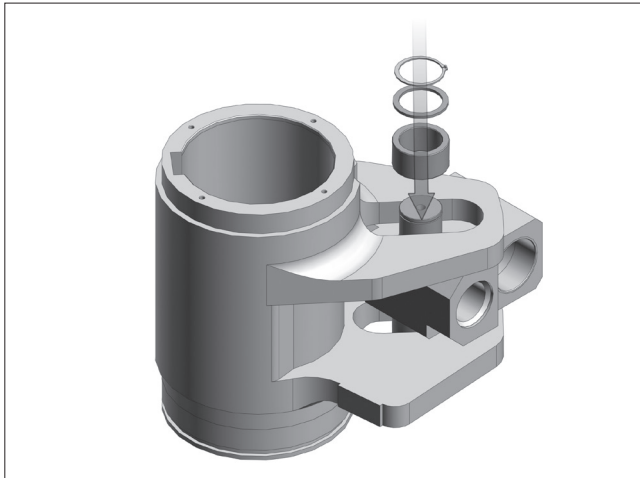

**Step 6.** Install the yoke assembly in the bottom bearing (56) of actuator with bottom side O-ring seal (36).



**Step 7.** Install top bearing (56) on yoke. Apply grease layer on bearing.

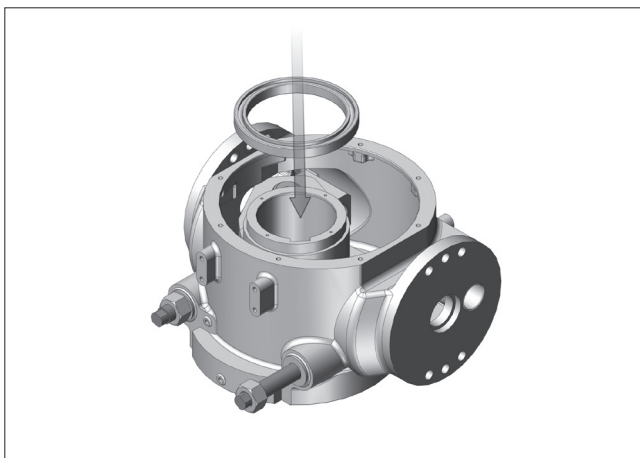

**Step 8.** Install yoke insert (19) with O-ring (35) on the top of yoke with the help of hex. head cap screw (57), apply grease on top side for yoke insert.

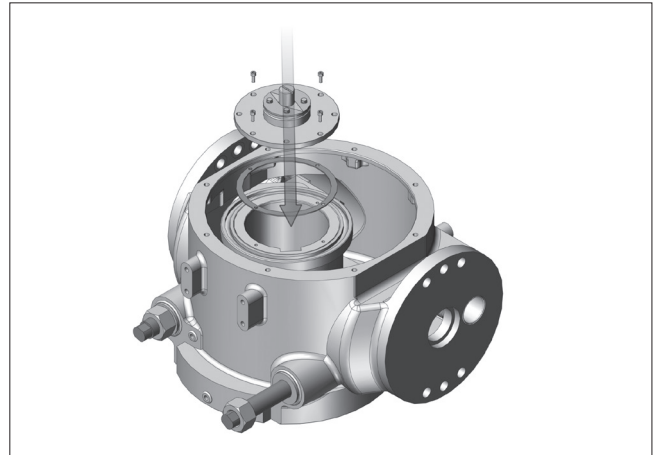

**Step 9.** Install guide rod (14) in central block housing (1) through carrier (15).

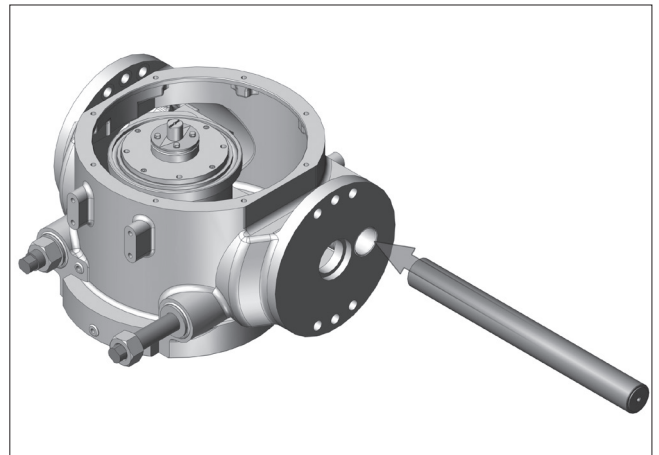

#### 4.4.1.2 A) Pneumatic Cylinder Module Reassembly: (For cylinder dia. 200 to 1300)

**Step 1.** Install outer O-ring (40) and rod seal (5) on bearing bush, lubricate bearing bush. Install assembly in front cover (3). Install retaining ring (45) on bearing bush & o-ring (32).

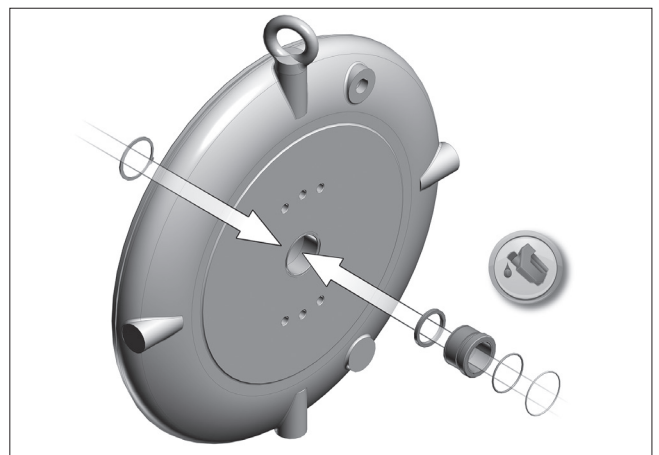

**Step 2.** Install O-ring (39) on front cover apply film of lubricant on cover O-ring.

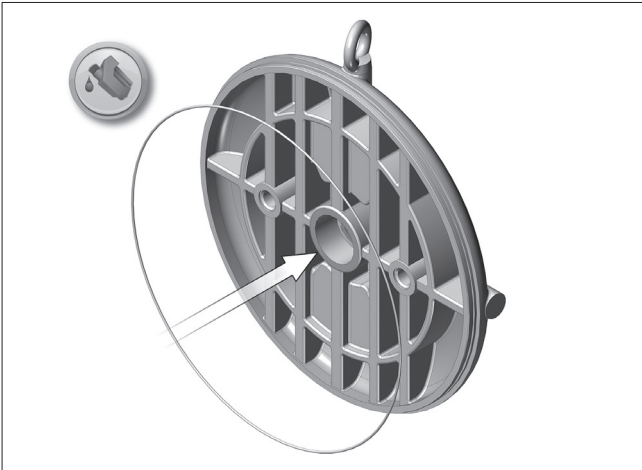

**Step 3.** Apply film of lubricant on tie rod (8) then install tie rod on front cover (3).

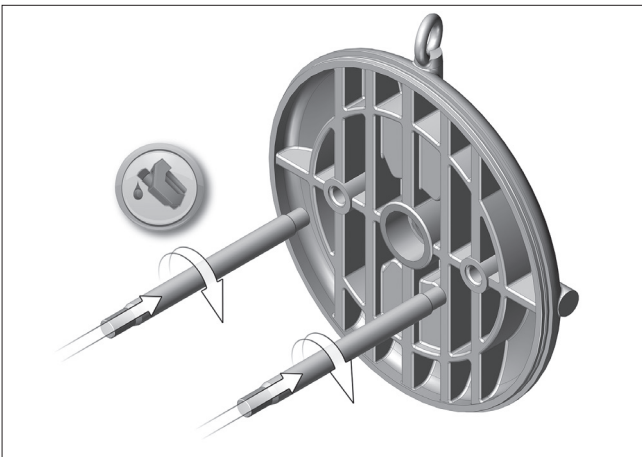

**Step 4.** Install outer O-ring (37) and internal x-ring (44) on guide bush (7), apply lubricant on outer and inner diameter of guide bush (7). Install guide bush in piston (6) & fix it with the help of retaining ring (62).

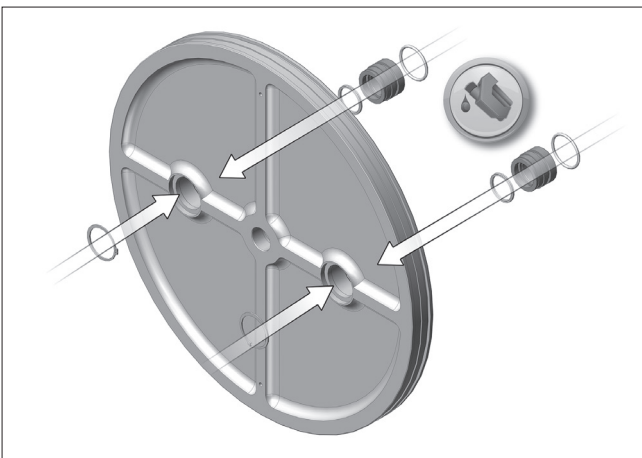

**Step 5.** Install o-ring (162), quad seal & piston strip on piston. Apply film lubricant on piston strip and piston seal. Install piston rod (9) on piston (6) by using lock nut (157). Do not fully tight this nut, keep it loose.

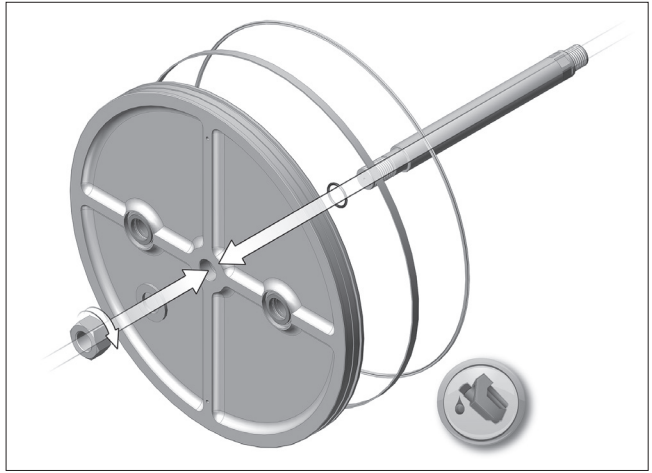

**Step 6.** Install piston assembly on tie rod (8). Ensure that piston rod will come out through front cover.

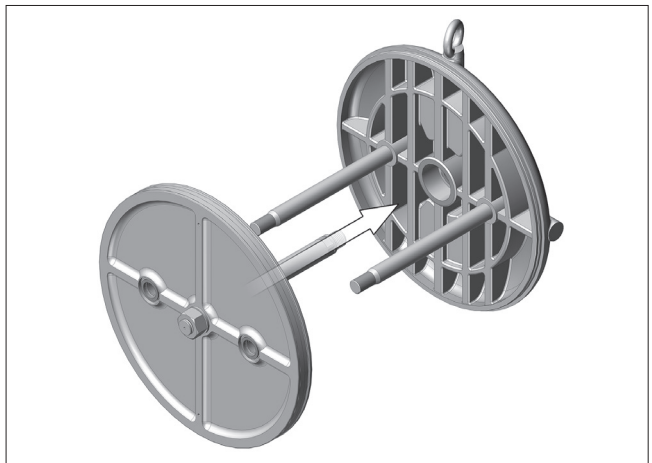

**Step 7.** Apply lubricant on cylinder tube (2) then install cylinder tube through piston (6) on front cover (3).

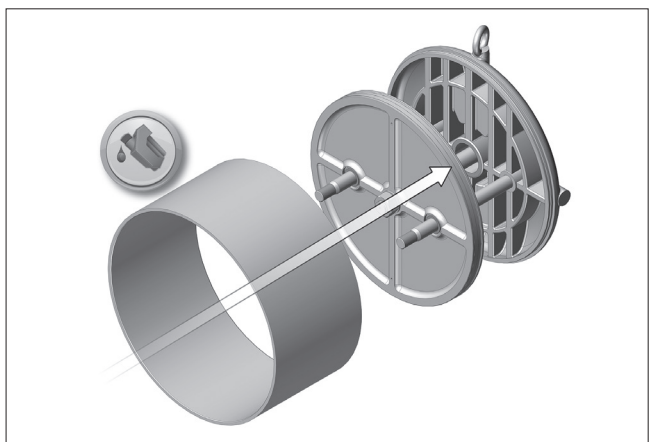

**Step 8.** Install O-ring (38, 39) on rear cover (10). Apply lubricant on both O-ring then, install rear cover in cylinder tube (2).

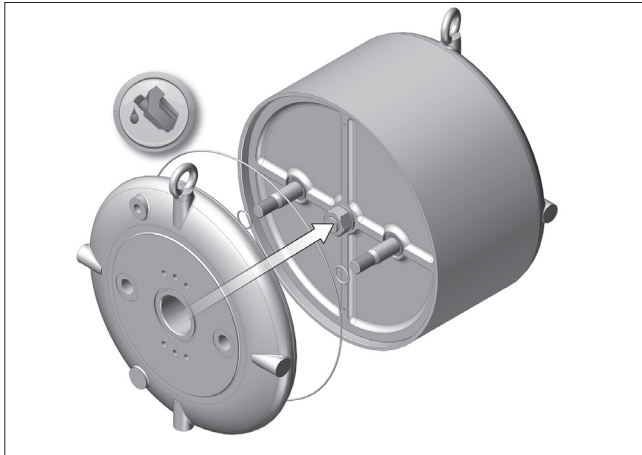

**Step 9.** Install hex nut (50) with spring washer (49) on tie rod to assemble the rear cover (10) on actuator. Apply pneumatic pressure to rear cover (10) to rotate actuator by 45°.

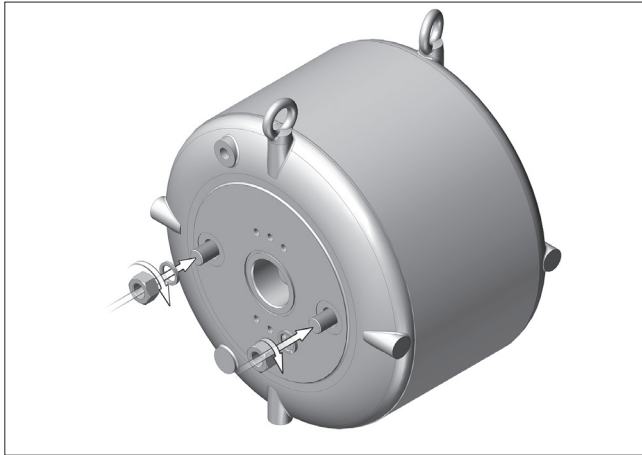

#### 4.4.1.2 B) Pneumatic Cylinder Module Reassembly: (For cylinder dia. 063 to 150)

**Step 1.** Install outer O-ring (40) and rod seal (31) on bearing bush, lubricate bearing bush. Install assembly in front cover (3). Install retaining ring (45) on bearing bush & o-ring (32).

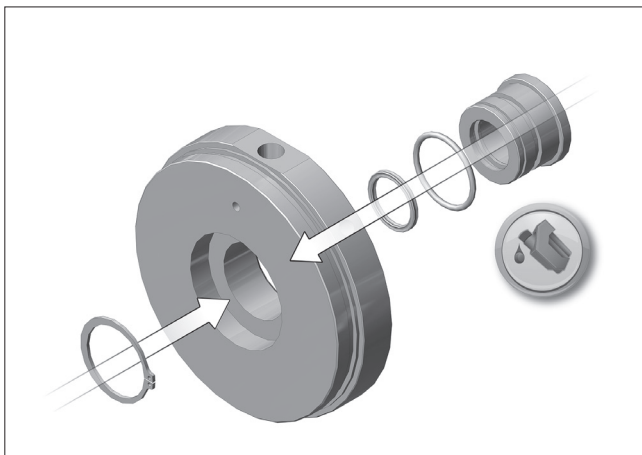

**Step 2.** Install O-ring (39) on front cover. Apply film of lubricant on cover O-ring. Assemble front cover assembly with cylinder tube. Apply lubricant on cylinder tube (2). Engagement between front cover & cylinder tube is through threaded joint. Rotate the front cover clockwise onto the tube threads & ensure proper engagement.

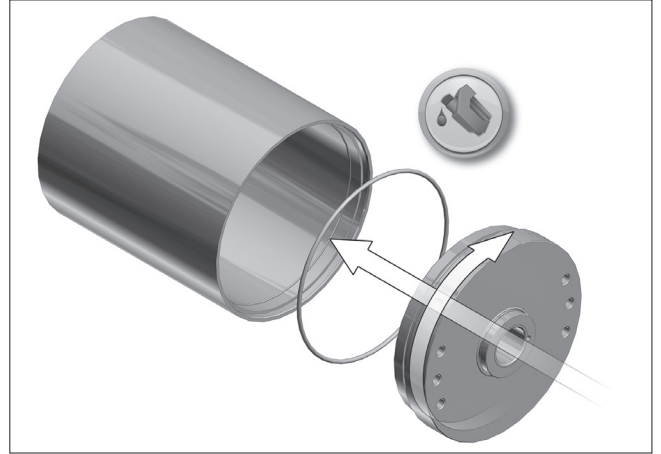

**Step 3.** Install piston strip (30), piston seal (43) & o-ring (162) of piston rod on piston (6) and apply film lubricant on piston strip, piston seal & o-ring (162).

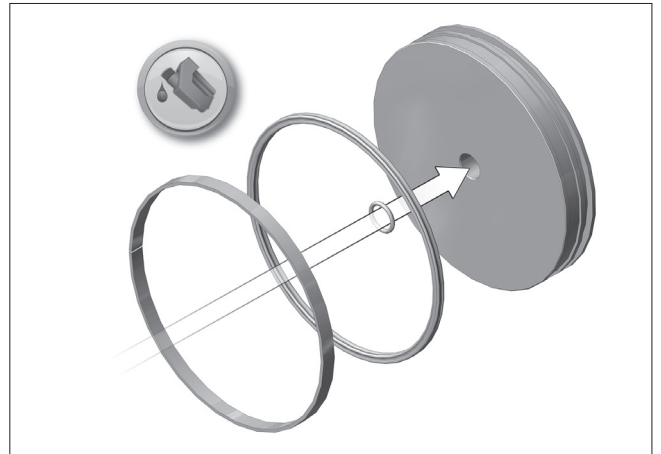

**Step 4.** Install piston rod (9) on piston (6) by using lock nut (157). Fully tighten this lock nut. (torque value provided in the table 4.12)

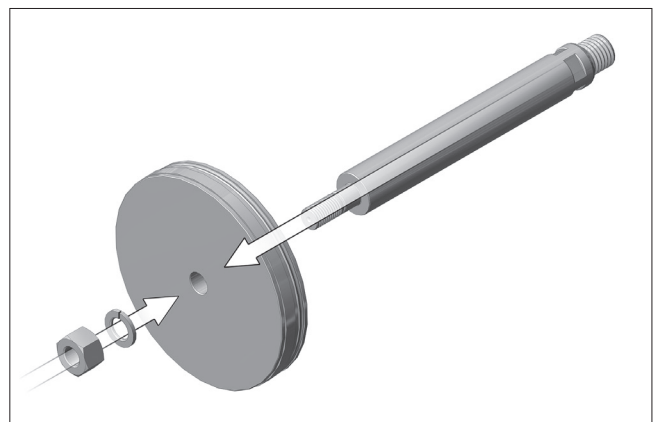

**Step 5.** Install piston assembly alongwith piston rod into the cylinder tube. Ensure piston rod come out of the front cover.

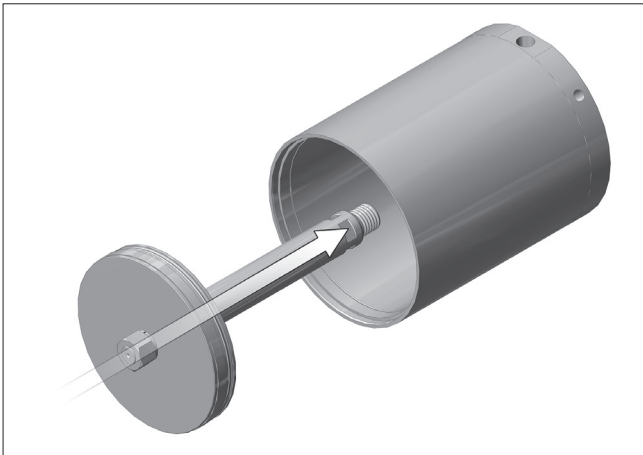

**Step 3.** Install pneumatic module on central block module with the help of studs / screws (11) & nuts (47).

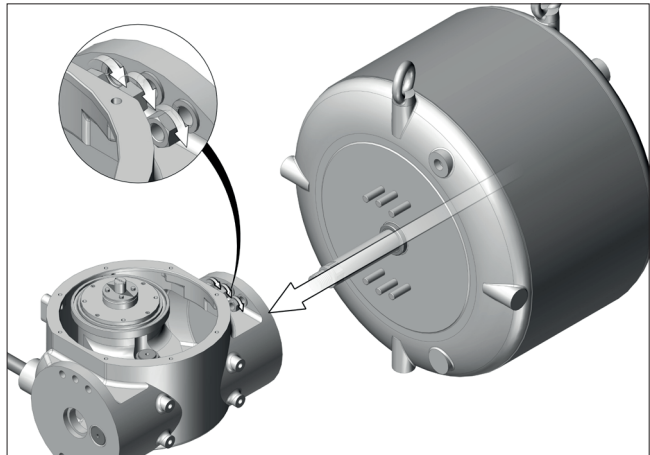

**Step 6.** Install O-ring (39) on rear cover. Apply film of lubricant on cover O-ring. Assemble rear cover with cylinder tube (2). Engagement between rear cover & cylinder tube is through threaded joint. Rotate the rear cover clockwise onto the tube threads & ensure proper engagement.

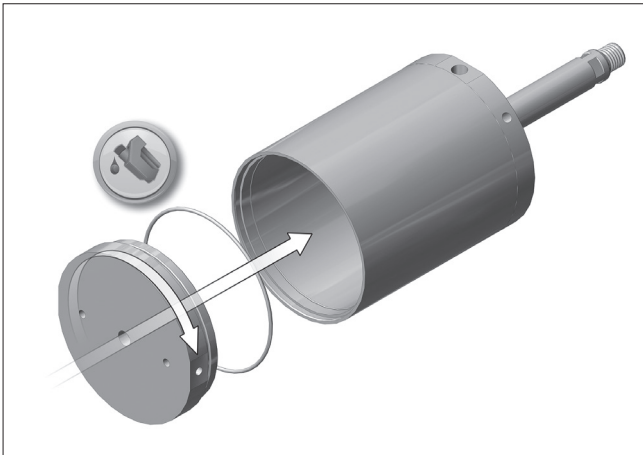

**Step 4.** Align piston rod (9) with carrier (15) and screw it in carrier (15). If required, apply pneumatic pressure to rear cover so as to move the piston rod towards carrier.

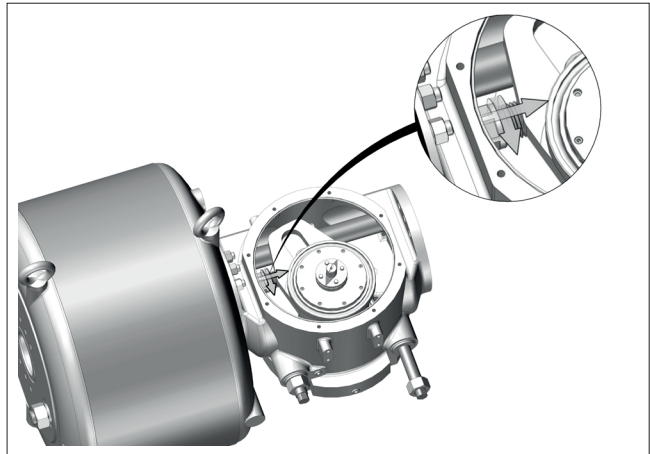

**Step 7.** Apply pneumatic pressure to rear cover (10) to rotate actuator by 45°.

**Step 5.** Fully tighten the piston rod lock nut (157) with the help of fixture through an open end of rear cover. If required, apply pneumatic pressure to front cover so as to move the piston towards rear side.

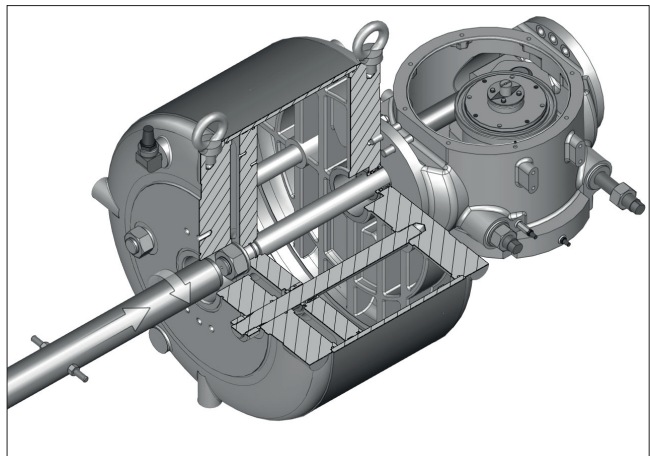

#### 4.4.1.3 A) Pneumatic Cylinder Module Installation:

**NOTE:**

Step 5 & 6 are not applicable for Cylinder diameter 63 to 150.

**Step 1.** Check to verify that o-ring seals (39), (42) are properly fitted in its seal groove on the front cover (3) and guide rod (14) respectively.

**Step 2.** Using lifting equipment move the pneumatic cylinder module up to central block module and align the piston rod to the centre of central block (1).

**Step 6.** Install o-ring (163) & rear plug (157) on rear cover with the help of socket head bolts (159).

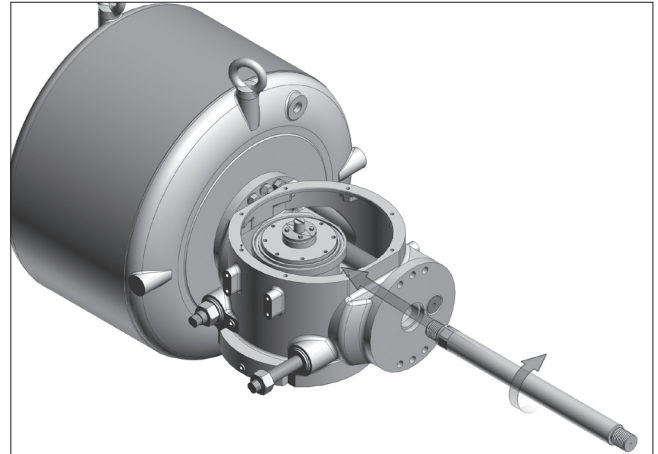
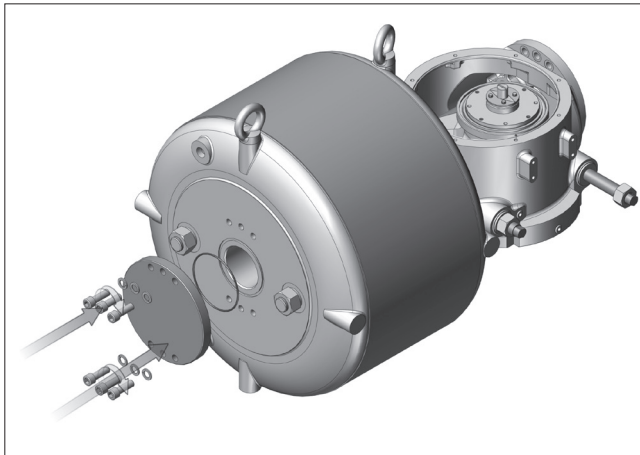

**NOTE:**

Clean the connecting rod and apply grease before installation.

**4.4.1.4 Spring Module Installation:**

**NOTE:**

This procedure is required to convert double acting actuator to single acting spring return actuator or to replace existing spring module assembly.

**Step 1.** To replace existing spring module, first, remove existing spring module from actuator refer section 4.6.1.1 for spring module removal.

**Step 2.** For double acting actuator before starting spring module installation procedure, actuator must be at over travel position. To over travel the actuator, unscrew the stroke adjustment screw (52) refer section 4.6.1.1 from step 2 to 3.

**Step 2.1.** Remove studs / hex cap screw (11) & nut (47) with lock washer (46) from central block to remove rear cap.

**Step 2.2.** Remove rear cap from central block housing. When removing rear cap from actuator assembly, be careful to lose O-ring seals.

**Step 4.** Align bearing bush (26) with connecting rod and central block.

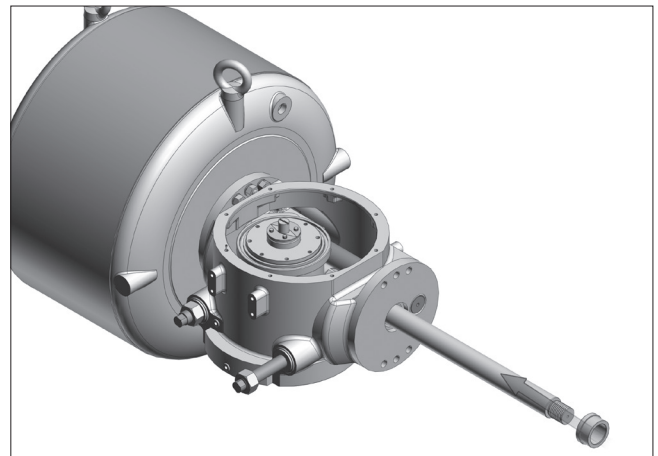

**NOTE:**

Apply grease inside diameter of bearing bush (26).

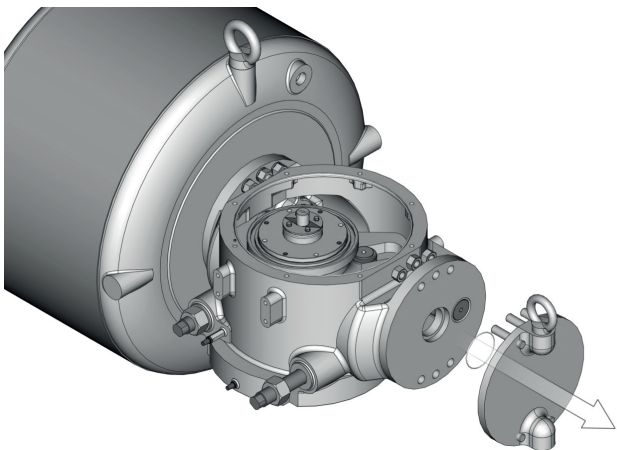

**Step 5.** Align spring assembly with actuator assembly and install o-ring seal (32) at front face of spring assembly and install o-ring (42) at the guide rod (14).

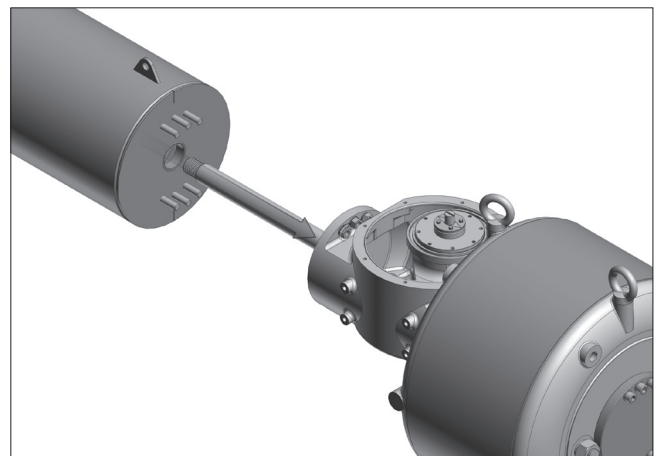

**Step 3.** Align connecting rod (27) with carrier and screw it in carrier (15).

**Step 6.** Install hex. Cap screw / stud (11) thru housing in spring module to assemble with actuator.

**Step 7.** Through the open end of spring module, install hexagon jam nuts (59) on connecting rod (27).

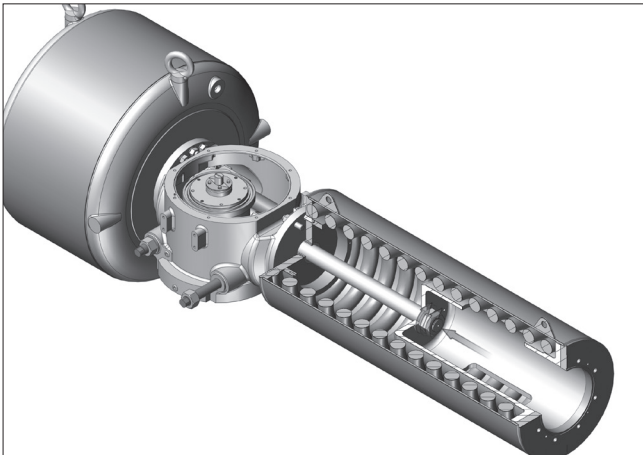

**Step 8.** Install o-ring seal (41) into the o-ring groove in the outboard end of spring module and then install rear cap (28).

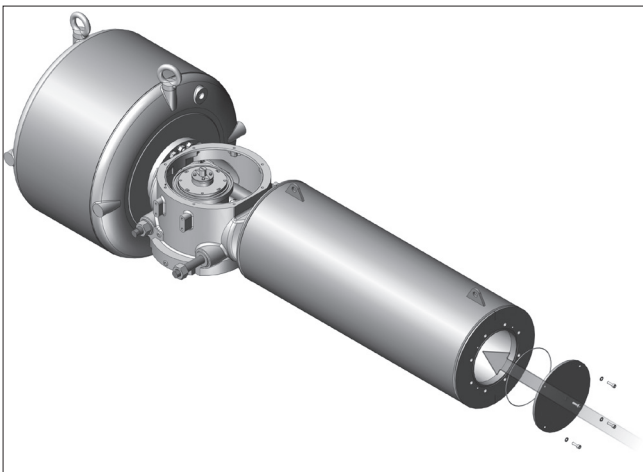

**Step 9.** Install top cover (12) with O-ring (33) on central block housing (1) with the help of hex. soc. head cap screw (55). Apply coat of lubricant on O-ring, and mating surfaces before installation.

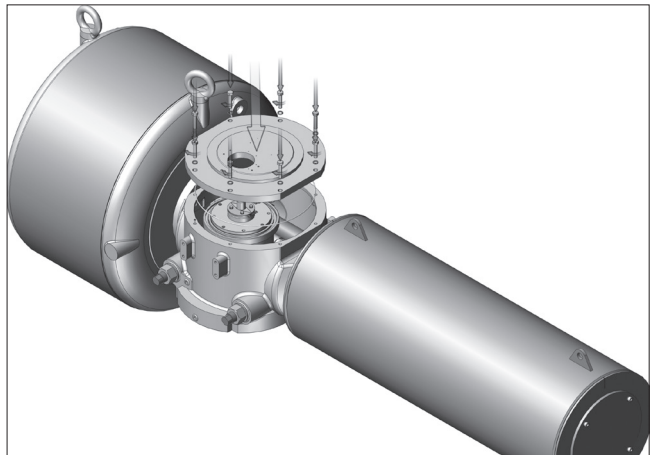

## 4.5 Stroke screw adjustment

1. Limit stop screw (52a, b) can be adjusted to get desired close & open setting of the valve respectively.
2. With stroke adjustment screw setting of  $\pm 5^\circ$  can be achieved in both positions.

3. Loosen nut (53) & rotate stroke adjustment screw in counter clockwise (CCW) direction to set over travel and clockwise (CW) direction to set under travel.

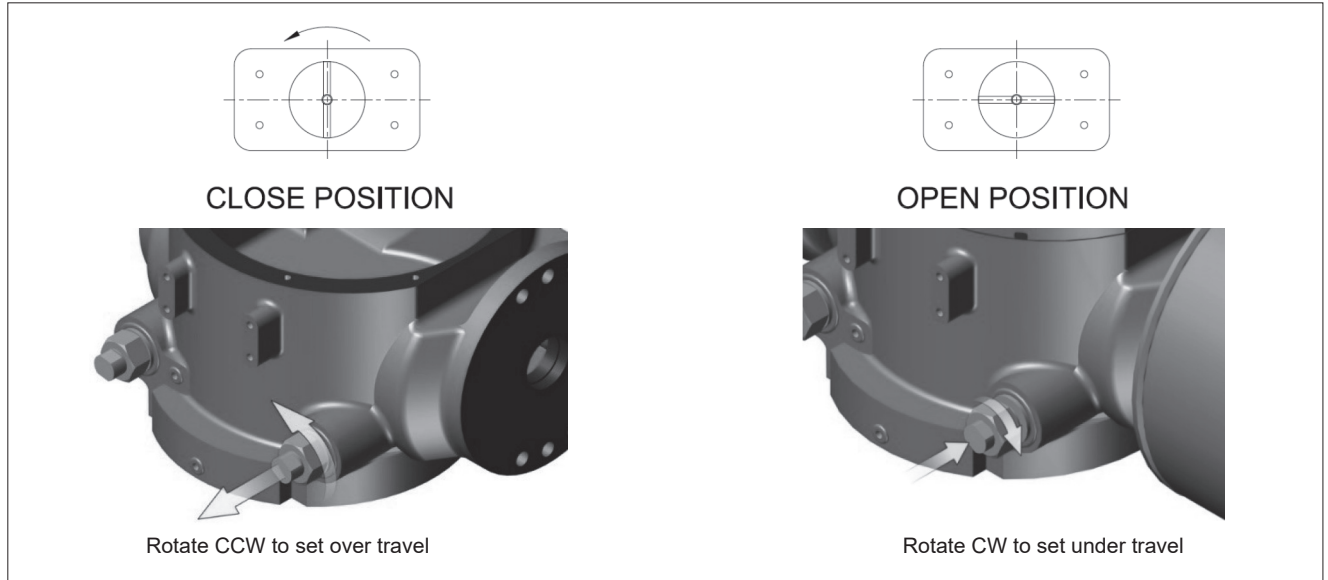

## 4.6 Field conversions

### Fail mode reversal (CW to CCW or CCW to CW)

**NOTE:**

Actuators must not undergo fail mode reversal without specific knowledge and acceptance of the resulting torque output. If a symmetrical yoke is being used during the process, then fail mode reversal will not affect the torque output.

**Step 1.** Remove spring module as per Chapter 4.3 - Section 4.3.1.1.

**Step 2.** Remove pneumatic cylinder module as per Chapter 4.3 - Section 4.3.1.2.

**Step 3.** Re-install the Spring Module onto the opposite end of central block housing (1), as it was previously located per Chapter 4.4 - Section 4.4.1.4.

**Step 4.** Re-install the pneumatic cylinder module onto the opposite end of central block housing (1), as it was previously located per Chapter 4.4 - Section 4.4.1.3.

### Converting double acting actuator to spring return

**Step 1.** Remove end cap as shown in Chapter 4.4 - Section 4.4.1.4 step 2, 2.1, 2.2.

**Step 2.** If Pneumatic cylinder Module needs to be relocated due to fail mode requirements (fail counter-clockwise) use Chapter 4.3 - Section 4.3.3 for removal and Section 4.3.4 for installation.

**Step 3.** Install the Spring Module on the central block housing (1), as it was previously located per Chapter 4.3 - Section 4.3.2.

### Converting spring return actuator to double acting

**Step 1.** Remove the Spring module as per Chapter 4.3 - Section 4.3.1.1.

**Step 2.** If Pneumatic cylinder Module needs to be relocated due to fail mode requirements (fail counter-clockwise) use Chapter 4.3 - Section 4.3.1.2 for removal and chapter 4.4 - Section 4.4.1.3 for installation.

**Step 3.** Install end cap as shown onto the opposite end of central block housing (1).

## 4.7 Malfunctions

Table 3 lists malfunctions that might occur after prolonged use.

Symptom	Possible cause	Action
Irregular or slow operation	Low supply pressure	Make sure that supply pressure complies with minimum torque required by valve. Check that supply air pipes are large enough.
	Positioner fault	Check positioner operation.
	Valve fault	Check that valve functions properly without actuator.
	Incorrect actuator rating	Contact manufacturer to check rating.
	Leak in piston or piston rod seal	Replace seals.
	Cylinder damaged by impurities	Note installation position recommendation. Replace cylinder if damaged.
	Worn-out actuator bearings	Check bearings. Replace bearings when necessary.
	Moving parts corroded in harsh, humid conditions	Replace the corroded parts.
Backlash in joint between actuator and valve	Replace parts as necessary.	

## 4.8 Tools

For maintenance of the N1 series actuator, you will need a few common tools.

Table 4 List of needed tools

Tool Style	Location	X	A	B	C	D	E	G	H	J	M
		TOOL SIZE									
Ring Spanner	38	8	10	17	17	19	19	19	24	30	30
Allen Key	41	4	5	5	5	5	5	6	6	6	8
Jaw spanner	44	30	46	65	65	65	75	85	95	125	-
Jaw spanner	43	24	36	46	46	55	55	65	95	105	180
Allen Key	45	8	14	19	19	19	22	22	27	-	-
Ring Spanner	47	13	17	19	19	24	30	36	36	46	55
Ring Spanner	50	Ø200-22	Ø250-22	Ø300-36	Ø350-36	Ø500-46	Ø600-55	Ø700-55	Ø700-55	Ø700-55	Ø1000-95
		Ø250-22	Ø300-36	Ø350-36	Ø400-46	Ø600-55	Ø700-55	Ø800-65	Ø800-65	Ø1100-105	
		Ø300-36	Ø350-36	Ø400-46	Ø500-46	Ø700-55	Ø800-65	Ø900-75	Ø900-75	Ø1200-105	
		Ø350-36	Ø400-46	Ø500-46	Ø600-55	Ø800-65	Ø900-75	Ø1000-95	Ø1000	Ø1300-130	
		Ø700-55	Ø900-75								

**NOTE:**

- \*Marked tools are used in single acting actuator only.
- \*\*Marked tools shows sizes in ØXXX-YY format where ØXXX- represents pneumatic bore diameter & YY represents tool size.

## 4.9 Tightening torque table

Table 5 Tightening torque table

Central Frame	Part No	Tightening Torque in Nm
N1X	55	2.5
	57	1.2
	53	NA
	47	10
N1A	55	4
	57	4.2
	53	NA
	47	20
N1B	55	20
	57	4.2
	53	NA
	47	35
N1C	20	580
	55	20
	57	4.2
	54	547
	53	NA
	51	510
N1D	47	35
	20	660
	55	35
	57	4.2
	54	748 (For cylinder 0350 to 0500 Dia)
	54	979 (For cylinder 0600 to 0700 Dia)
	53	NA
	51	550 (For cylinder 0350 to 0500 Dia)
	51	1040 (For cylinder 0600 to 0700 Dia)
	47	87
N1E	159	87 (For cylinder 0600 to 0700 Dia)
	20	1470
	55	35
	57	4.5
	54	1465 (For cylinder 0500 to 0700 Dia)
	54	1988 (For cylinder 0800 to 0900 Dia)
	53	NA
	51	1310
	47	170
	159	170 (For cylinder 0700 to 0900 Dia)
N1G	20	1470
	55	35
	57	10
	54	1770 (For cylinder 0600 to 0700 Dia)
	54	2868 (For cylinder 0800 to 0900 Dia)
	53	NA
	51	1310
	47	293
N1H	159	293 (For cylinder 0700 to 0900 Dia)
	20	2290
	55	87
	57	10
	54	2540 (For cylinder 0700 to 0800 Dia)
	54	3963 (For cylinder 0900 to 1000 Dia)
	53	NA
	51	2060
N1J	47	293
	159	293 (For cylinder 0900 to 1000 Dia)
	20	2890 (For cylinder 0700 & 0800 Dia)
	20	4810 (For cylinder 0900 & 1000 Dia)
	55	170
	57	10
	54	3408 (For cylinder 0700 to 0800 Dia)
	54	5112 (For cylinder 0900 to 1000 Dia)
N1M	53	NA
	51	2610 (For cylinder 0700 & 0800 Dia)
	51	4000 (For cylinder 0900 & 1000 Dia)
	47	582
	20	6390 (For cylinder 1000 & 1100 Dia)
	20	9580 (For cylinder 1200 & 1300 Dia)
	55	170
	57	10
	54	7604 (For cylinder 1000 to 1100 Dia)
	54	10266 (For cylinder 1200 to 1300 Dia)
N1M	53	NA
	51	5960 (For cylinder 1000 & 1100 Dia)
	51	8300 (For cylinder 1200 & 1300 Dia)
	47	1017

Part No	Pneumatic Bore dia	Tightening Torque in Nm
50	200	62
	250	62
	300	125
	350	125
	400	283
	500	283
	600	619
	700	619
	800	942
	900	1340
	1000	2164
	1100	3672
	1200	3672
1300	4871	

## 4.10 Ordering spare parts

### NOTE:

Use only original spare parts. This ensures proper functioning of the actuator.

When ordering spare parts, always include following information.

- Type code, sales order number, serial number
- Number of the parts list, part number, name of the part and required quantity

This information can be found from the identification plate or documents.

## 4.11 Lifting tool table

Below sizes of D shackle shall be used for lifting of actuator with slings.

For single acting actuators

D shackle sizes	Single acting
N1X to N1B	1/4"
N1C	5/16"
N1D	7/16"
N1E	1/2"
N1G	7/8"
N1H	7/8"
N1J	1"
N1M	1-1/2"

For double acting actuators

D shackle sizes	Double acting
N1X TO N1C	1/4"
N1D	5/16"
N1E	7/16"
N1G	5/8"
N1H	5/8"
N1J	7/8"
N1M	1"

## 4.12 For ordering spare seal kit

(1) Seal kit assembly for N1 actuator consists of following:

Seal kit assembly for single acting actuator consists of -

1. Seal kit for central block assembly
2. Seal kit for pneumatic side assembly
3. O-ring

Seal kit assembly for double acting actuator consists of -

1. Seal kit for central block assembly
2. Seal kit for pneumatic side assembly

Refer below table for ordering of complete seal kit assembly

1	2	3	4	5	6	7	8
SKAN1	A	0250	S	1	G	E	NP1

1.	Series
SKAN1	Seal kit assembly for Neles heavy duty actuator

2.	Frame size
A	X
	A
	B
	C
	D
	E
	G
	H
	J
	M

3.	Cylinder size	Available frame
0250	0063	X
	0080	X
	0100	X, A
	0125	X, A
	0150	A
	0200	A
	0250	A, B
	0300	A, B, C
	0350	A, B, C, D
	0400	B, C, D
	0500	C, D, E
	0600	D, E, G
	0700	D, E, G, H, J
	0800	E, G, H, J
	0900	E, G, H, J
	1000	H, J, M
	1100	M
1200	M	
1300	M	

4.	Link type
S	Symmetric

5.	Cylinder type
1	Single cylinder

6.	Seal material
G	Nitrile, NBR
H	Viton
A	Fluorosilicone

7.	Single / Double acting (1)
E	Single acting
D	Double acting

8.	
NP1	New threaded carrier design

Refer below tables for ordering of individual seal kits of central block assembly & pneumatic side assembly.

Seal Kit for Central block

1.	2.	3.	4.	5*
SKN1	A	CB	G	NP1

1.	Series
SKN1	Seal kit for Neles heavy duty actuator

2.	Frame size
A	X
	A
	B
	C
	D
	E
	G
	H
	J
	M

3.	Module
CB	Central Block

4.	Seal Material
G	Nitrile, NBR
H	Viton
A	Fluorosilicone

5.	
NP1	New threaded carrier design

\* - Add 'Option 5' only for frame D, E & G. To be left blank for all other frames.

Seal Kit for Pneumatic side

1.	2.	3.	4.	5.	6
SKN1	A	PS	0080	G	NP1

1.	Series
SKN1	Seal kit for Neles heavy duty actuator

2.	Frame size
A	X
	A
	B
	C
	D
	E
	G
	H
	J
	M

3.	Module
PS	Pneumatic side

4.	Cylinder Size	Available frame
0080	0063	X
	0080	X
	0100	X, A
	0125	X, A
	0150	A
	0200	A
	0250	A, B
	0300	A, B, C
	0350	A, B, C, D
	0400	B, C, D
	0500	C, D, E
	0600	D, E, G
	0700	D, E, G, H, J
	0800	E, G, H, J
	0900	E, G, H, J
	1000	H, J, M
1100	M	
1200	M	
1300	M	

3.	Cylinder size	Available frame
0250	0063	X
	0080	X
	0100	X, A
	0125	X, A
	0150	A
	0200	A
	0250	A, B
	0300	A, B, C
	0350	A, B, C, D
	0400	B, C, D
	0500	C, D, E
	0600	D, E, G
	0700	D, E, G, H, J
	0800	E, G, H, J
	0900	E, G, H, J
	1000	H, J, M
1100	M	
1200	M	
1300	M	

5.	Seal Material
G	Nitrile, NBR
H	Viton
A	Fluorosilicone

4.	Link type
S	Symmetric

6.	
NP1	New threaded carrier design

5.	Cylinder type
1	Single cylinder

6.	Single / Double acting <sup>(2)</sup>
E	Single acting
D	Double acting

<sup>(2)</sup> Bearing kit for N1 actuator consists of following:

Bearing kit for single acting actuator consists of -

1. Bearing bush – Pneumatic side
2. Guide bush – Applicable for actuator cylinder size Dia. 0200 & above
3. Bearing bush – Spring side
4. Piston strip
5. Yoke bearing

Bearing kit for double acting actuator

1. Bearing bush – Pneumatic side
2. Guide bush – Applicable for actuator cylinder size dia. 0200 & above
3. Piston strip
4. Yoke bearing

7.	
NP1	New threaded carrier design

## 4.13 Recommended Lubricants

NBR & Viton seals (General use)	Velloguard VG9
Fluorosilicon seals (High temperature)	Aeroshell Grease 7

Refer below table for ordering of bearing kit

1	2	3	4	5	6	7
BKN1	A	0250	S	1	E	NP1

1.	Series
BKN1	Bearing kit for Neles heavy duty actuator

2.	Frame size
A	X
	A
	B
	C
	D
	E
	G
	H
	J
M	

# 5. EXPLODED VIEWS AND PARTS LIST

## 5.1 Double acting actuators N1\_D00

CYLINDER SIZES FROM 63 TO 150

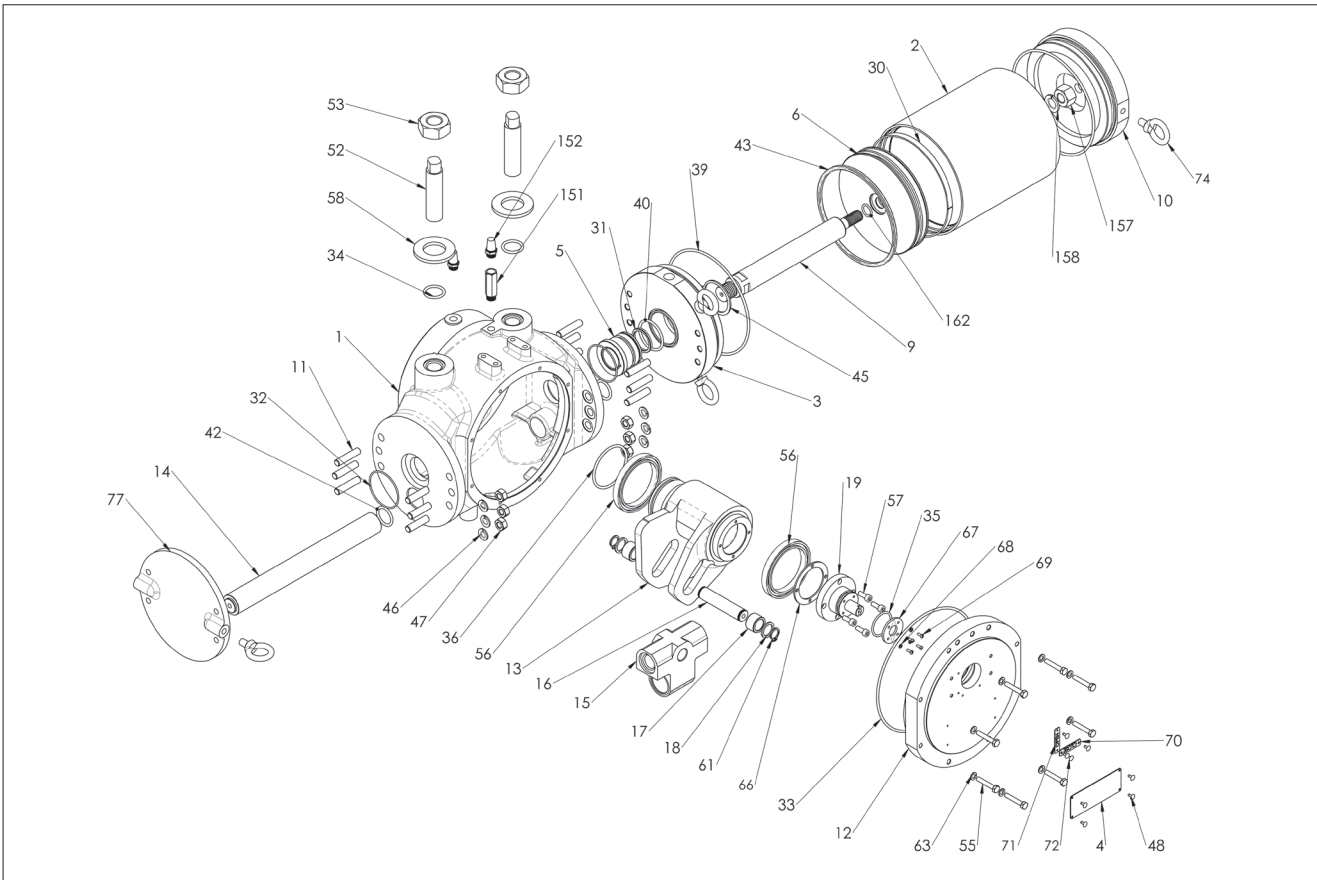

ITEM NO.	DISCRPTION	QTY.	MATERIAL
1	CENTRAL BLOCK	1	DUCTILE IRON
2	CYLINDER	1	CARBON STEEL (CHROME PLATED)
3	CYLINDER FRONT COVER	1	CARBON STEEL
4	NAME PLATE	1	STAINLESS STEEL
5#	BEARING BUSH	1	CARBONSTEEL + PHOSPHOR BRONZE
6	PISTON	1	CARBON STEEL
9	PISTON ROD	1	STAINLESS STEEL
10	CYLINDER REAR COVER	1	CARBON STEEL
11	STUD BOLT	12	ALLOY STEEL
12	CENTRAL BLOCK COVER	1	DUCTILE IRON
13	YOKE	1	DUCTILE IRON
14	GUIDE ROD	1	STAINLESS STEEL
15	CARRIER	1	DUCTILE IRON
16	YOKE PIN	1	ALLOY STEEL
17	ROLLER FOR YOKE PIN	2	ALLOY STEEL
18	WASHER	2	STAINLESS STEEL
19	YOKE INSERT	1	DUCTILE IRON
30#	PISTON STRIP	1	DELTRIN
31*\$	ROD SEAL	1	NBR
32*\$	O-RING	2	NBR
33*\$	O-RING	1	NBR
34*\$	O-RING	2	NBR
35*\$	O-RING	1	NBR
36*\$	O-RING	1	NBR
39*\$	O-RING	2	NBR
40*\$	O-RING	1	NBR

ITEM NO.	DISCRPTION	QTY.	MATERIAL
42*\$	O-RING	2	NBR
43*\$	QUAD SEAL	1	NBR
45	EXTERNAL CIRCLIP	1	DIN 471
46	SPRING WASHER	12	DIN 128
47	HEX. NUT	12	DIN 934
48	RIVET	4	-
52	STROKE ADJUSTMENT SCREW	2	CARBON STEEL
53	HEX. NUT	2	DIN 934
55	HEX. SOC. HEAD CAP SCREW	8	DIN 912
56#	RADIAL BALL BEARING	2	-
57	HEX. SOC. HEAD CAP SCREW	4	DIN 912
58	WASHER	2	CARBON STEEL
61	EXTERNAL CIRCLIP	2	DIN 471
63	SPRING WASHER	8	DIN 128
66*\$	GASKET FOR COVER	1	NBR
67	POSITION INDICATOR	1	ALUMINIUM ALLOY
68	SPRING WASHER	4	DIN 128
69	SLOTTED HEAD CAP SCREW	4	IS 6101
70	CLOSE POSITION INDICATOR	1	STAINLESS SHEEL
71	OPEN POSITION INDICATOR	1	STAINLESS STEEL
72	RIVET	4	-
74	EYEBOLT	3	STD
77	REAR CAP	1	DUCTILE IRON
151	CHECK VALVE	1	STD
152	SILENCER	2	BRASS
157	HEX NUT FOR PISTON ROD	1	DIN 934
158	SPRING WASHER	1	DIN 128
162*\$	O-RING	1	NBR

1) \* Marked components are the parts of the seal kit  
 2) # Marked components are the parts of the repair kit  
 3) \$ marked components having following notes:  
 3.4) For Soft parts (seal kit), MOC Mentioned is "NBR" for Standard temperature option. MOC will be "VITON" for hightemp. option. MOC will be "VITON" for hightemp. option, "FLUOROSILICONE" for arctic temp. option.

## 5.2 Double acting actuators N1\_D00

CYLINDER SIZES FROM 200 TO 1300

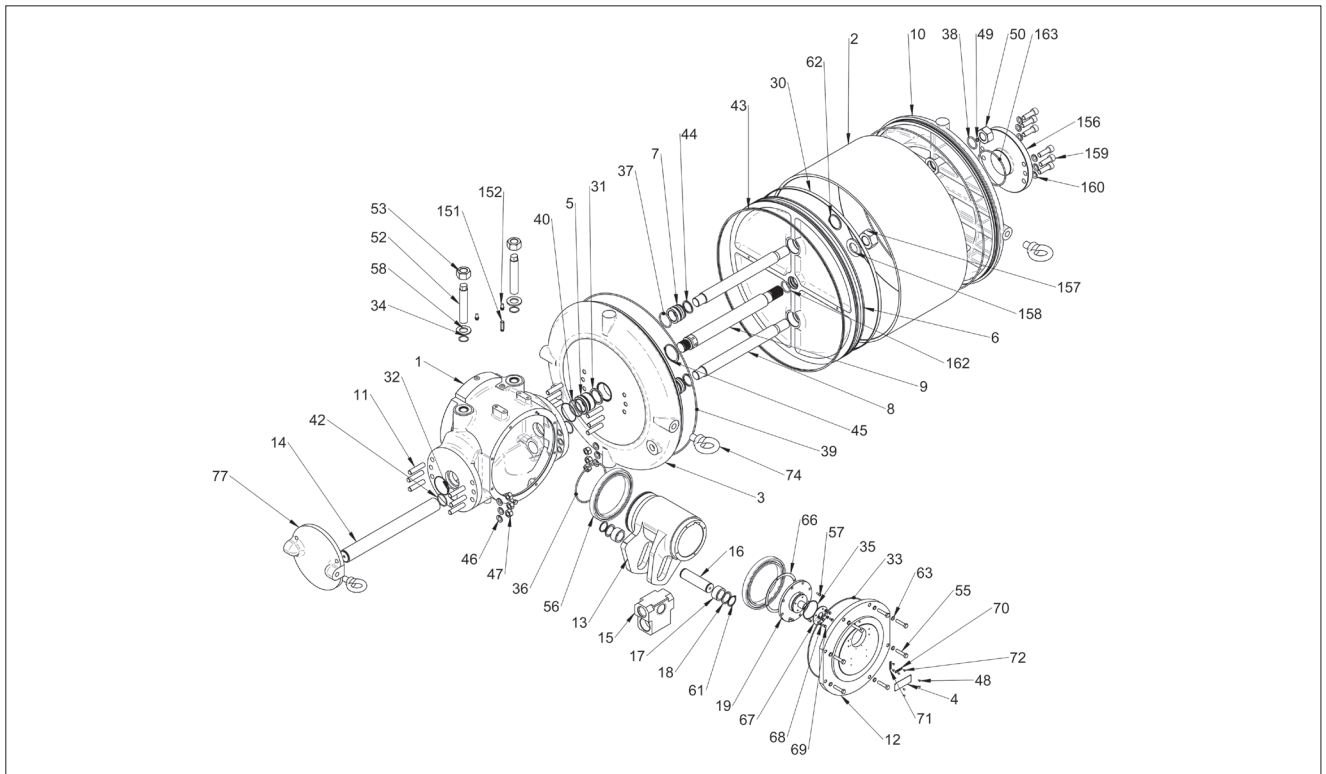

ITEM NO.	DISCRIPTION	QTY.	MATERIAL
1	CENTRAL BLOCK	1	DUCTILE IRON
2	CYLINDER	1	CARBON STEEL (CHROME PLATED)
3\$	CYLINDER FRONT COVER	1	CARBON STEEL / DUCTILE IRON
4	NAME PLATE	1	STAINLESS STEEL
5#	BEARING BUSH	1	CARBONSTEEL + PHOSPHOR BRONZE
6\$	PISTON	1	CARBON STEEL / DUCTILE IRON
7#	GUIDE BUSH	2	CARBONSTEEL + PHOSPHOR BRONZE
8	TIE ROD	2	STAINLESS STEEL
9	PISTON ROD	1	STAINLESS STEEL
10\$	CYLINDER REAR COVER	1	CARBON STEEL / DUCTILE IRON
11	STUD BOLT	12	ALLOY STEEL
12	CENTRAL BLOCK COVER	1	DUCTILE IRON
13	YOKE	1	DUCTILE IRON
14	GUIDE ROD	1	STAINLESS STEEL
15\$	CARRIER	1	DUCTILE IRON / CARBON STEEL
16	YOKE PIN	1	ALLOY STEEL
17	ROLLER FOR YOKE PIN	2	ALLOY STEEL
18	WASHER	2	STAINLESS STEEL
19	YOKE INSERT	1	DUCTILE IRON
30#	PISTON STRIP	1	PTFE
31*\$	ROD SEAL	1	NBR
32*\$	O-RING	2	NBR
33*\$	O-RING	1	NBR
34*\$	O-RING	2	NBR
35*\$	O-RING	1	NBR
36*\$	O-RING	1	NBR
37*\$	O-RING	2	NBR
38*\$	O-RING	2	NBR
39*\$	O-RING	2	NBR
40*\$	O-RING	1	NBR
42*\$	O-RING	2	NBR
43*\$	QUAD SEAL	1	NBR
44*\$	QUAD SEAL	2	NBR
45	EXTERNAL CIRCLIP	1	DIN 471

ITEM NO.	DISCRIPTION	QTY.	MATERIAL
46	SPRING WASHER	12	DIN 128
47	HEX. NUT	12	DIN 934
48	RIVET	4	-
49	SPRING WASHER	2	DIN 934
50	HEX. NUT	2	DIN 934
52	STROKE ADJUSTMENT SCREW	2	CARBON STEEL
53	HEX. NUT	2	DIN 934
55	HEX. HEAD SCREW	8	DIN 912
56#	RADIAL BALL BEARING	2	-
57	HEX. SOC. HEAD CAP SCREW	4	DIN 912
58	WASHER	2	CARBON STEEL
61	EXTERNAL CIRCLIP	2	DIN 471
62	EXTERNAL CIRCLIP	2	DIN 471
63	SPRING WASHER	8	DIN 128
66*\$	GASKET FOR COVER	1	NBR
67	POSITION INDICATOR	1	ALUMINIUM ALLOY
68	SPRING WASHER	4	DIN 128
69	SLOTTED HEAD CAP SCREW	4	IS 6101
70	CLOSE POSITION INDICATOR	1	STAINLESS STEEL
71	OPEN POSITION INDICATOR	1	STAINLESS STEEL
72	RIVET	4	-
74	EYEBOLT	3	STD
77	REAR CAP	1	DUCTILE IRON
151	CHECK VALVE	1	DUCTILE IRON
152	SILENCER	2	BRASS
156	REAR PLUG	1	CARBON STEEL
157	HEX NUT FOR PISTON ROD	1	DIN 934
158	SPRING WASHER	1	DIN 128
159	HEX. SOC. HEAD CAP SCREW	6	DIN 912
160	SPRING WASHER	6	DIN 128
162*\$	O-RING	1	NBR
163*\$	O-RING	1	NBR

- 1) \* Marked components are the parts of the seal kit
- 2) # Marked components are the parts of the repair kit
- 3) \$ marked components having following notes:
  - 3.1) For Pneumatic side Front Cover, Rear Cover & Piston (Item no 3, 6 & 10 resp.), from bore dia 0200 to 900mm MOC is Ductile iron. Rest of other sizes Front Cover, Rear Cover & Piston (Item no 3, 6 & 10 resp.)
  - 3.2) Carrier (Item no 15). For bore dia 200 MOC is Ductile iron, for rest of other sizes MOC is Carbon steel.
  - 3.3) For Soft parts (seal kit), MOC Mentioned is "NBR" for Standard temperature option. MOC will be "VITON" for high temp. option, "FLUOROSILICONE" for arctic temp. option..

## 5.3 Single acting actuators N1\_E\_C

CYLINDER SIZES FROM 63 TO 150

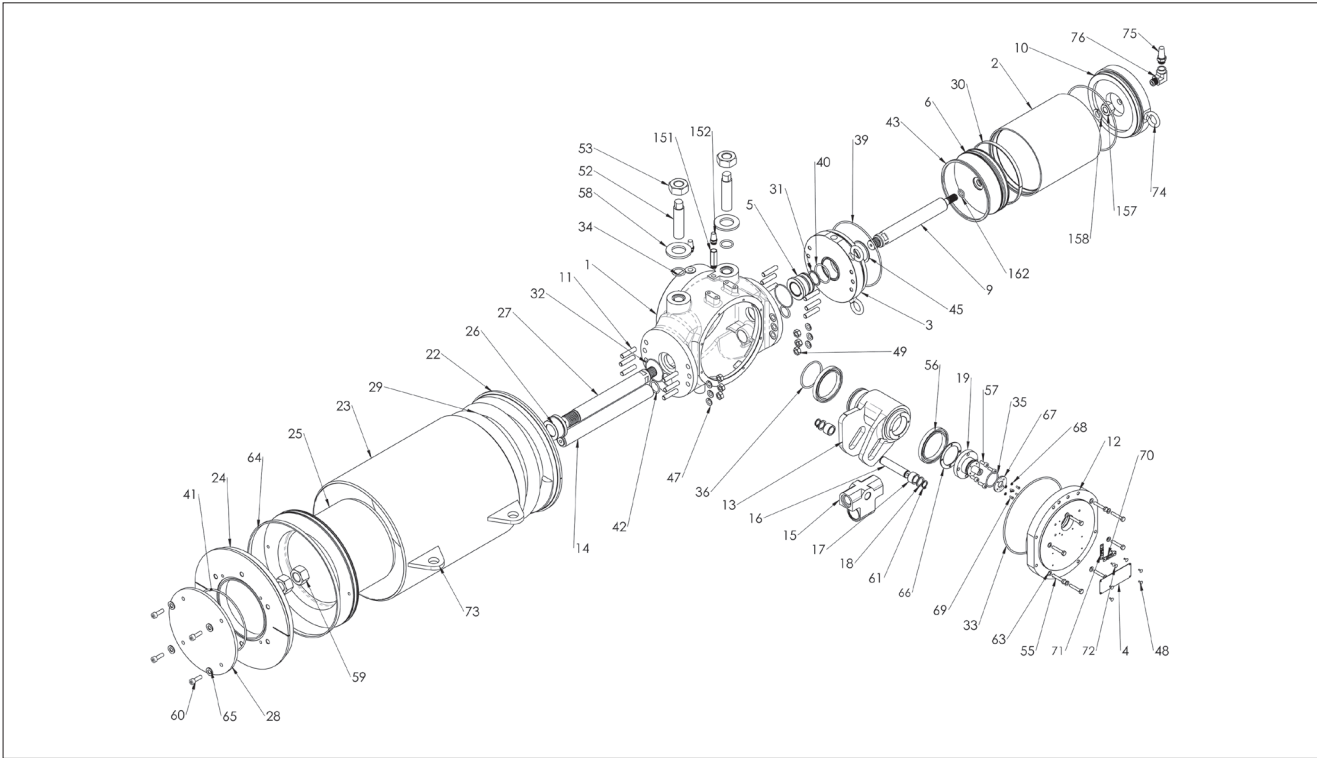

ITEM NO.	DISCRIPTION	QTY.	MATERIAL
1	CENTRAL BLOCK	1	DUCTILE IRON
2	CYLINDER	1	CARBON STEEL (CHROME PLATED)
3	CYLINDER FRONT COVER	1	CARBON STEEL
4	NAME PLATE	1	STAINLESS STEEL
5	BEARING BUSH	1	CARBONSTEEL
6	PISTON	1	CARBON STEEL
9	PISTON ROD	1	STAINLESS STEEL
10	CYLINDER REAR COVER	1	CARBON STEEL
11	STUD BOLT	12	ALLOY STEEL
12	CENTRAL BLOCK COVER	1	DUCTILE IRON
13	YOKE	1	DUCTILE IRON
14	GUIDE ROD	1	STAINLESS STEEL
15	CARRIER	1	DUCTILE IRON
16	YOKE PIN	1	ALLOY STEEL
17	ROLLER FOR YOKE PIN	2	ALLOY STEEL
18	WASHER	2	STAINLESS STEEL
19	YOKE INSERT	1	DUCTILE IRON
22	SPRING COVER FRONT END	1	CARBON STEEL
23	E- TUBE	1	CARBON STEEL
24	SPRING COVER REAR END	1	CARBON STEEL
25	SPRING RETAINER	1	DUCTILE IRON
26#	BEARING BUSH	1	CARBONSTEEL+PHOSPHOR BRONZE
27	CONNECTING ROD	1	STAINLESS STEEL
28	E-COVER REAR CAP	1	CARBON STEEL
29	SPRING	1	SPRING STEEL
30#	PISTON STRIP	1	DELTRIN
31*\$	ROD SEAL	1	NBR
32*\$	O-RING	2	NBR
33*\$	O-RING	1	NBR
34*\$	O-RING	2	NBR
35*\$	O-RING	1	NBR
36*\$	O-RING	1	NBR
39*\$	O-RING	2	NBR
40*\$	O-RING	1	NBR

ITEM NO.	DISCRIPTION	QTY.	MATERIAL
41*\$	O-RING	1	NBR
42*\$	O-RING	2	NBR
43*\$	QUAD SEAL	1	NBR
45	EXTERNAL CIRCLIP	1	DIN 471
46	SPRING WASHER	12	DIN 128
47	HEX. NUT	12	DIN 934
48	RIVET	4	-
52	STROKE ADJUSTMENT SCREW	2	CARBON STEEL
53	HEX. NUT	2	DIN 934
55	HEX. HEAD SCREW	8	DIN 912
56#	RADIAL BALL BEARING	2	-
57	HEX. SOC. HEAD CAP SCREW	4	DIN 912
58	WASHER	2	CARBON STEEL
59	HEXAGON JAM NUT	2	-
60	HEX. SOC. HEAD CAP SCREW	4	DIN 912
61	EXTERNAL CIRCLIP	2	DIN 471
63	SPRING WASHER	8	DIN 128
64	RETAINER GUIDE STRIP	1	PTFE
65	SPRING WASHER	4	DIN 128
66*\$	GASKET FOR COVER	1	NBR
67	POSITION INDICATOR	1	ALUMINIUM ALLOY
68	SPRING WASHER	4	DIN 128
69	SLOTTED HEAD CAP SCREW	4	IS 6101
70	CLOSE POSITION INDICATOR	1	STAINLESS STEEL
71	OPEN POSITION INDICATOR	1	STAINLESS STEEL
72	RIVET	4	-
73	LIFTING LUG	2	MILD STEEL
74	EYEBOLT	2	STD
75	SILENCER	1	BRASS
76	ELBOW FITTING	1	STAINLESS STEEL
151	CHECK VALVE	1	STD
152	SILENCER	2	BRASS
157	HEX NUT FOR PISTON ROD	1	DIN 934
158	SPRING WASHER	1	DIN 128
162*\$	O-RING	1	NBR

1) \* Marked components are the parts of the seal kit

2) # Marked components are the parts of the repair kit

3) \$ marked components having following notes:

3.1) For Soft parts (seal kit), MOC Mentioned is "NBR" for Standard temperature option. MOC will be "VITON" for high temp. option "FLUOROSILICONE" for arctic temp. option.

# 5.4 Single acting actuators N1\_E\_C

## CYLINDER SIZES FROM 200 TO 1300

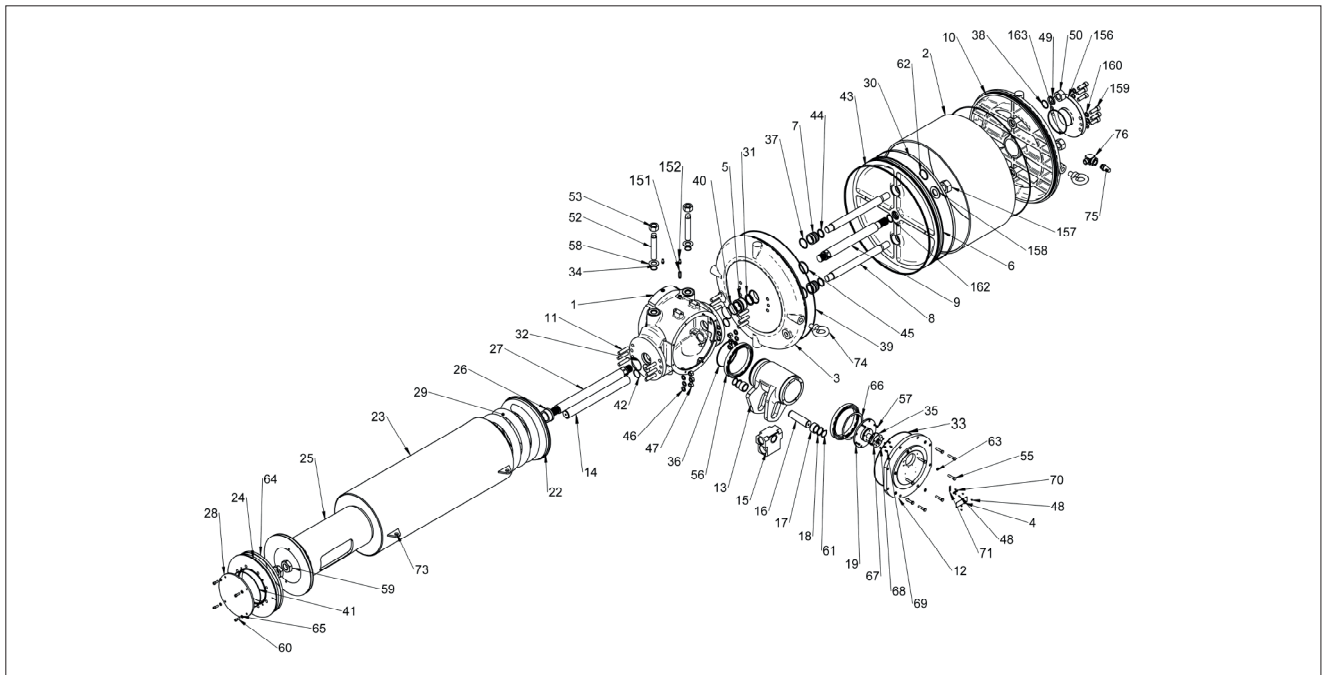

ITEM NO.	DISCRIPTION	QTY.	MATERIAL
1	CENTRAL BLOCK	1	DUCTILE IRON
2	CYLINDER	1	CARBON STEEL (CHROME PLATED)
3\$	CYLINDER FRONT COVER	1	CARBON STEEL/ DUCTILE IRON
4	NAME PLATE	1	STAINLESS STEEL
5#	BEARING BUSH	1	CARBONSTEEL + PHOSPHOR BRONZE
6\$	PISTON	1	CARBON STEEL/ DUCTILE IRON
7#	GUIDE BUSHING	2	CARBONSTEEL + PHOSPHOR BRONZE
8	TIE ROD	2	STAINLESS STEEL
9	PISTON ROD	1	STAINLESS STEEL
10\$	CYLINDER REAR COVER	1	CARBON STEEL/ DUCTILE IRON
11	STUD BOLT	12	ALLOY STEEL
12	CENTRAL BLOCK COVER	1	DUCTILE IRON
13	YOKE	1	DUCTILE IRON
14	GUIDE ROD	1	STAINLESS STEEL
15\$	CARRIER	1	DUCTILE IRON / CARBON STEEL
16	YOKE PIN	1	ALLOY STEEL
17	ROLLER FOR YOKE PIN	2	ALLOY STEEL
18	WASHER	2	STAINLESS STEEL
19	YOKE INSERT	1	DUCTILE IRON
22	SPRING COVER FRONT END	1	CARBON STEEL
23	E- TUBE	1	CARBON STEEL
24	SPRING COVER REAR END	1	CARBON STEEL
25\$	SPRING RETAINER	1	DUCTILE IRON / CARBON STEEL
26#	BEARING BUSH	1	CARBONSTEEL + PHOSPHOR BRONZE
27	CONNECTING ROD	1	STAINLESS STEEL
28	E-COVER REAR CAP	1	CARBON STEEL
29	SPRING	1	SPRING STEEL
30#	PISTON STRIP	1	DELIRIN
31*\$	ROD SEAL	1	NBR
32*\$	O-RING	2	NBR
33*\$	O-RING	1	NBR
34*\$	O-RING	2	NBR
35*\$	O-RING	1	NBR
36*\$	O-RING	1	NBR
37*\$	O-RING	2	NBR
38*\$	O-RING	2	NBR
39*\$	O-RING	2	NBR
40*\$	O-RING	1	NBR
41*\$	O-RING	1	NBR
42*\$	O-RING	2	NBR

ITEM NO.	DISCRIPTION	QTY.	MATERIAL
43*\$	QUAD SEAL	1	NBR
44*\$	QUAD SEAL	2	NBR
45	EXTERNAL CIRCLIP	1	DIN 471
46	SPRING WASHER	12	DIN 128
47	HEX. NUT	12	DIN 934
48	RIVET	4	-
49	SPRING WASHER	2	DIN 934
50	HEX NUT	2	DIN 934
52	STROKE ADJUSTMENT SCREW	2	CARBON STEEL
53	HEX. NUT	2	DIN 934
55	HEX. HEAD SCREW	8	DIN 912
56#	RADIAL BALL BEARING	2	-
57	HEX. SOC. HEAD CAP SCREW	4	DIN 912
58	WASHER	2	CARBON STEEL
59	HEXAGON JAM NUT	2	-
60	HEX. SOC. HEAD CAP SCREW	4	DIN 912 CLASS-8.8
61	EXTERNAL CIRCLIP	2	DIN 471
62	EXTERNAL CIRCLIP	2	DIN 471
63	SPRING WASHER	8	DIN 128
64	RETAINER GUIDE STRIP	1	PTFE
65	SPRING WASHER	4	DIN 128
66*\$	GASKET FOR COVER	1	NBR
67	POSITION INDICATOR	1	ALUMINIUM ALLOY
68	SPRING WASHER	4	DIN 128
69	SLOTTED HEAD CAP SCREW	4	IS 6101
70	CLOSE POSITION INDICATOR	1	STAINLESS STEEL
71	OPEN POSITION INDICATOR	1	STAINLESS STEEL
72	RIVET	4	-
73	LIFTING LUG	2	MILD STEEL
74	EYEBOLT	2	STD
75	SILENCER	1	BRASS
76	ELBOW FITTING	1	STAINLESS STEEL
151	CHECK VALVE	1	STD
152	SILENCER	2	BRASS
156	REAR PLUG	1	CARBON STEEL
157	HEX NUT FOR PISTON ROD	1	DIN 934
158	SPRING WASHER	1	DIN 128
159	HEX. SOC. HEAD CAP SCREW	6	DIN 912
160	SPRING WASHER	6	DIN 128
162*\$	O-RING	1	NBR
163*\$	O-RING	1	NBR

- 1. \* Marked components are the parts of the seal kit
- 2) # Marked components are the parts of the repair kit
- 3) \$ marked components having following notes:
- 3.1) For Pneumatic side Front Cover, Rear Cover & Piston (Item no 3, 6 & 10 resp.), from bore dia 0200 to 900mm MOC is Ductile iron. Rest of other sizes Front Cover, Rear Cover & Piston (Item no 3, 6 & 10 resp.) MOC is carbon steel.
- 3.2) MOC is carbon steel.
- 3.3) Spring retainer (Item no 25), from frame N1A to N1E MOC is Ductile iron & From frame N1G to N1M MOC is Carbon steel.
- 3.4) Carrier (Item no 15). For bore dia 200 MOC is Ductile iron, for rest of other sizes MOC is Carbon steel.
- 3.4) For Soft parts (seal kit), MOC Mentioned is "NBR" for Standard temperature option. MOC will be "VITON" for high temp. option "FLUOROSILICONE" for arctic temp. option.

# 6. DIMENSIONS AND WEIGHTS

## 6.1 Dimensions double acting

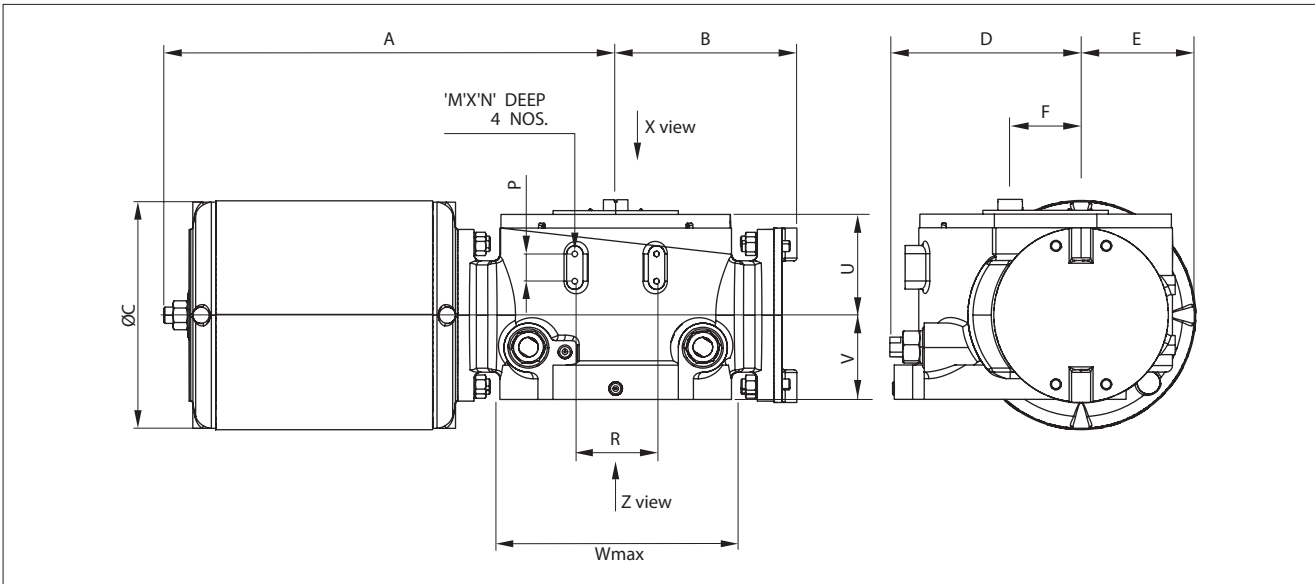

DIMENSION - DOUBLE ACTING ACTUATOR, mm														
MODEL	A	B	Øc	D	E	F	M	N	P	R	W max	U	V	S
N1X0063	250	107	84	116	73	28	M6	9	20	30	125	67	58	1/4" NPT
N1X0080	250	107	100	116	73	28	M6	9	20	30	125	67	58	1/4" NPT
N1X0100	262	107	122	116	73	28	M6	9	20	30	125	67	58	1/4" NPT
N1X0125	285	107	150	116	73	28	M6	9	20	30	125	67	58	1/4" NPT
N1A0100	389	171	122	194	88	58	M8	12	25	60	200	94	86	1/4" NPT
N1A0125	411	171	150	194	88	58	M8	12	25	60	200	94	86	1/4" NPT
N1A0150	395	171	175	194	88	58	M8	12	25	60	200	94	86	3/8" NPT
N1A0200	476	171	210	194	88	58	M8	12	25	60	200	94	86	1/2" NPT
N1A0250	418	171	263	194	131.5	58	M8	12	25	60	200	94	86	1/2" NPT
N1A0300	456	171	314	194	157	58	M8	12	25	60	200	94	86	3/4" NPT
N1A0350	459	171	364	194	182	58	M8	12	25	60	200	94	86	3/4" NPT
N1B0250	574	230	263	245	131.5	75	M10	15	25	80	210	102	105	1/2" NPT
N1B0300	548	230	308	245	155	75	M10	15	25	80	210	102	105	3/4" NPT
N1B0350	551	230	360	245	180	75	M10	15	25	80	210	102	105	3/4" NPT
N1B0400	596	230	416	245	208	75	M10	15	25	80	210	102	105	3/4" NPT
N1C0300	599	248	308	252	155	90	M10	15	50	90	294	130	112	3/4" NPT
N1C0350	583	248	360	252	180	90	M10	15	50	90	294	130	112	3/4" NPT
N1C0400	660	248	416	252	208	90	M10	15	50	90	294	130	112	3/4" NPT
N1C0500	675	248	522	252	257	90	M10	15	50	90	294	130	112	3/4" NPT
N1D0300	786	328	308	321	180	108	M12	15	50	150	350	138	121	3/4" NPT
N1D0350	789	328	366	321	180	108	M12	15	50	150	350	138	121	3/4" NPT
N1D0400	736	328	416	321	208	108	M12	15	50	150	350	138	121	3/4" NPT
N1D0500	739	328	522	321	257	108	M12	15	50	150	350	138	121	3/4" NPT
N1D0600	766.5	328	625	321	312	108	M12	15	50	150	350	138	121	1" NPT
N1D0700	815.5	328	725	321	404	108	M12	15	50	150	350	138	121	1" NPT
N1E0500	832	365	522	368	257	130	M12	15	50	150	425	199	155	3/4" NPT
N1E0600	849	365	625	368	312	130	M12	15	50	150	425	199	155	1" NPT
N1E0700	909	365	725	368	404	130	M12	15	50	150	425	199	155	1" NPT
N1E0800	920	365	826	368	458	130	M12	15	50	150	425	199	155	1" NPT
N1E0900	986	365	926	368	558	130	M12	15	50	150	425	199	155	1 1/2" NPT
N1G0600	975	450	625	444	312	160	M12	15	50	150	475	251	177	1" NPT
N1G0700	1040	450	725	444	404	160	M12	15	50	150	475	251	177	1" NPT
N1G0800	1065	450	826	444	458	160	M12	15	50	150	475	251	177	1" NPT
N1G0900	1095	450	926	444	558	160	M12	15	50	150	475	251	177	1 1/2" NPT
N1H0700	1228	566	725	549	404	198	M12	15	50	150	600	222	213	1" NPT
N1H0800	1253	566	824	549	458	198	M12	15	50	150	600	222	213	1" NPT
N1H0900	1305	566	926	549	558	198	M12	15	50	150	600	222	213	1 1/2" NPT
N1H1000	1284	566	1040	549	549	198	M12	15	50	150	600	222	213	1 1/2" NPT
N1J0700	1498	676	725	677	404	260	M16	32	100	300	686	299	247	1" NPT
N1J0800	1517	676	824	677	458	260	M16	32	100	300	686	299	247	1" NPT
N1J0900	1570	676	926	677	558	260	M16	32	100	300	686	299	247	1 1/2" NPT
N1J1000	1529	676	1040	677	549	260	M16	32	100	300	686	299	247	1 1/2" NPT
N1M1000	1865	851	1040	884	520	335	M20	40	100	300	1164	300	270	1 1/2" NPT
N1M1100	1935	851	1150	884	575	335	M20	40	100	300	1164	300	270	2" NPT
N1M1200	1945	851	1250	884	625	335	M20	40	100	300	1164	300	270	2" NPT
N1M1300	1945	837	1350	884	675	335	M20	40	100	300	1164	300	270	2" NPT

## 6.2 Weights double acting

Cyl. Diam	63	80	100	125	150	200	250	300	350	400	500	600	700	800	900	1000	1100	1200	1300
Actuator	weight, kg																		
N1X	18	20	22	29	-	-	-	-	-	-	-	-	-	-	-	-	-	-	-
N1A	-	-	52	57	63	65	68	90	98	-	-	-	-	-	-	-	-	-	-
N1B	-	-	-	-	-	-	106	122	135	181	-	-	-	-	-	-	-	-	-
N1C	-	-	-	-	-	-	-	145	165	207	274	-	-	-	-	-	-	-	-
N1D	-	-	-	-	-	-	-	-	245	276	342	441	563	-	-	-	-	-	-
N1E	-	-	-	-	-	-	-	-	-	-	450	541	677	872	1102	-	-	-	-
N1G	-	-	-	-	-	-	-	-	-	-	-	633	853	1057	1278	-	-	-	-
N1H	-	-	-	-	-	-	-	-	-	-	-	-	1138	1345	1580	2785	-	-	-
N1J	-	-	-	-	-	-	-	-	-	-	-	-	1610	1800	2041	3300	-	-	-
N1M	-	-	-	-	-	-	-	-	-	-	-	-	-	-	-	4500	5644	6130	6950

## 6.3 Dimensions single acting

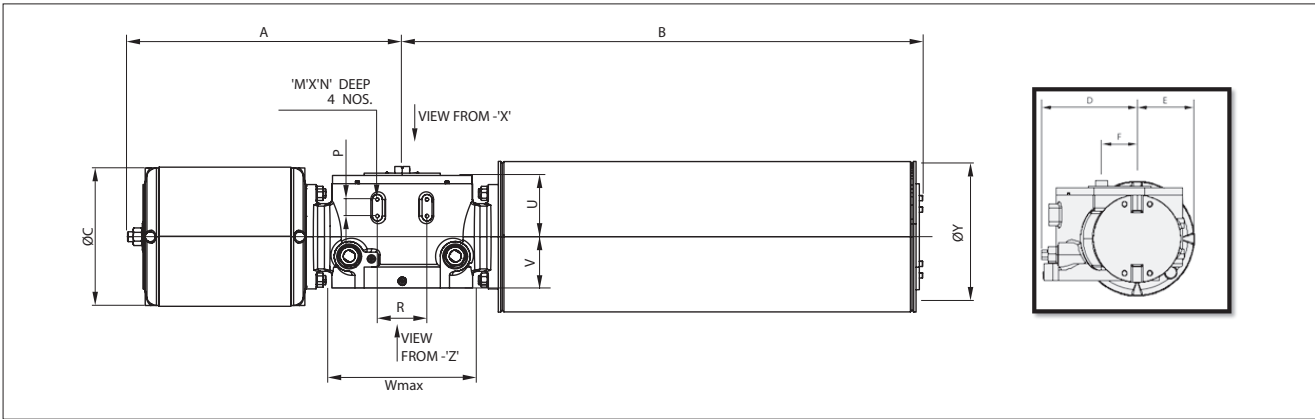

DIMENSION- SINGLE ACTING ACTUATOR, mm																
MODEL	A	B	Øc	D	E	F	M	N	P	R	W max	U	V	ØY	S	
N1X0063-E4-E5	250	365	84	116	73	28	M6	9	20	30	125	67	58	170	1/4" NPT	
N1X0080-E1-E5	250	365	100	116	73	28	M6	9	20	30	125	67	58	170	1/4" NPT	
N1X0100-E1-E4	262	365	122	116	73	28	M6	9	20	30	125	67	58	170	1/4" NPT	
N1X0125-E1-E2	285	365	150	116	73	28	M6	9	20	30	125	67	58	170	1/4" NPT	
N1A0100-E9-E11	389	498	122	194	88	58	M8	12	25	60	200	94	86	255	1/4" NPT	
N1A0125-E7	411	573	150	194	88	58	M8	12	25	60	200	94	86	310	1/4" NPT	
N1A0125-E8-E11	411	498	150	194	88	58	M8	12	25	60	200	94	86	255	1/4" NPT	
N1A0150-E6-E7	395	573	175	194	88	58	M8	12	25	60	200	94	86	310	3/8" NPT	
N1A0150-E8-E11	395	498	175	194	88	58	M8	12	25	60	200	94	86	255	3/8" NPT	
N1A0200-E4	476	612	210	194	88	58	M8	12	25	60	200	94	86	320	1/2" NPT	
N1A0200-E5-E6	476	573	210	194	88	58	M8	12	25	60	200	94	86	310	1/2" NPT	
N1A0250-E1-E4	418	612	263	194	131.5	58	M8	12	25	60	200	94	86	320	1/2" NPT	
N1A0250-E5-E6	418	573	263	194	131.5	58	M8	12	25	60	200	94	86	310	1/2" NPT	
N1A0300-E1-E4	456	612	314	194	157	58	M8	12	25	60	200	94	86	320	3/4" NPT	
N1A0300-E5	456	573	314	194	157	58	M8	12	25	60	200	94	86	310	3/4" NPT	
N1A0350-E1-E4	459	612	364	194	182	58	M8	12	25	60	200	94	86	320	3/4" NPT	
N1B0250-E3-E6	574	955	263	245	131.5	75	M10	15	25	80	210	102	105	321	1/2" NPT	
N1B0300-E1-E6	548	955	308	245	155	75	M10	15	25	80	210	102	105	321	3/4" NPT	
N1B0350-E1-E6	551	955	360	245	180	75	M10	15	25	80	210	102	105	321	3/4" NPT	
N1B0400-E1-E6	596	955	416	245	208	75	M10	15	25	80	210	102	105	321	3/4" NPT	
N1C0300-E3-E4	599	1060	308	252	155	90	M10	15	50	90	294	130	112	379	3/4" NPT	
N1C0350-E1-E4	583	1060	360	252	180	90	M10	15	50	90	294	130	112	379	3/4" NPT	
N1C0400-E1-E4	660	1060	416	252	208	90	M10	15	50	90	294	130	112	379	3/4" NPT	
N1C0500-E1-E4	675	1060	522	252	257	90	M10	15	50	90	294	130	112	379	3/4" NPT	
N1D0300-E4	786	1287	308	321	180	108	M12	15	50	150	350	138	121	434	3/4" NPT	
N1D0350-E4	789	1287	366	321	180	108	M12	15	50	150	350	138	121	434	3/4" NPT	
N1D0400-E3-E4	736	1287	416	321	208	108	M12	15	50	150	350	138	121	434	3/4" NPT	
N1D0500-E1-E4	739	1287	522	321	257	108	M12	15	50	150	350	138	121	434	3/4" NPT	
N1D0600-E1-E4	766.5	1287	625	321	312	108	M12	15	50	150	350	138	121	434	1" NPT	
N1D0700-E1-E3	815.5	1287	725	321	404	108	M12	15	50	150	350	138	121	434	1" NPT	
N1E0500-E4	832	1573	522	368	257	130	M12	15	50	150	425	199	155	454	3/4" NPT	
N1E0600-E1-E4	849	1573	625	368	312	130	M12	15	50	150	425	199	155	454	1" NPT	
N1E0700-E1-E4	909	1573	725	368	404	130	M12	15	50	150	425	199	155	454	1" NPT	
N1E0800-E1-E4	920	1573	826	368	458	130	M12	15	50	150	425	199	155	454	1" NPT	
N1E0900-E1-E3	986	1573	926	368	558	130	M12	15	50	150	425	199	155	454	1 1/2" NPT	
N1G0600-E3-E4	975	2380	625	444	312	160	M12	15	50	150	475	251	177	550	1" NPT	
N1G0700-E2-E4	1040	2380	725	444	404	160	M12	15	50	150	475	251	177	550	1" NPT	
N1G0800-E1-E4	1065	2380	826	444	458	160	M12	15	50	150	475	251	177	550	1" NPT	
N1G0900-E1-E4	1095	2380	926	444	558	160	M12	15	50	150	475	251	177	550	1 1/2" NPT	
N1H0700-E3	1228	1942	725	549	404	198	M12	15	50	150	600	222	213	605	1" NPT	
N1H0800-E2	1253	2382	824	549	458	198	M12	15	50	150	600	222	213	605	1" NPT	
N1H0800-E3	1253	1942	824	549	458	198	M12	15	50	150	600	222	213	605	1" NPT	
N1H0900-E1	1305	2615	926	549	558	198	M12	15	50	150	600	222	213	684	1 1/2" NPT	
N1H0900-E2	1305	2382	926	549	558	198	M12	15	50	150	600	222	213	605	1 1/2" NPT	
N1H0900-E3	1305	1942	926	549	558	198	M12	15	50	150	600	222	213	605	1 1/2" NPT	
N1H1000-E1	1284	2615	1040	549	549	198	M12	15	50	150	600	222	213	684	1 1/2" NPT	
N1H1000-E2	1284	2382	1040	549	549	198	M12	15	50	150	600	222	213	628	1 1/2" NPT	
N1H1000-E3	1284	1942	1040	549	549	198	M12	15	50	150	600	222	213	605	1 1/2" NPT	
N1J0800-E4	1517	2868	824	677	458	260	M16	32	100	300	686	299	247	782	1" NPT	
N1J0900-E2-E4	1570	2868	926	677	558	260	M16	32	100	300	686	299	247	782	1 1/2" NPT	
N1J1000-E2-E4	1529	2868	1040	677	549	260	M16	32	100	300	686	299	247	782	1 1/2" NPT	
N1M1100-E4	1935	3040	1150	884	620	335	M20	40	100	300	1164	300	270	1070	2" NPT	
N1M1200-E3-E4	1945	3040	1250	884	625	335	M20	40	100	300	1164	300	270	1070	2" NPT	
N1M1300-E3-E4	1945	3040	1350	884	675	335	M20	40	100	300	1164	300	270	1070	2" NPT	

## 6.4 Weights single acting

Cyl. Diam	63	80	100	125	150	200	250	300	350	400	500	600	700	800	900	1000	1100	1200	1300
Actuator	weight, kg																		
N1X	35	38	40	43	-	-	-	-	-	-	-	-	-	-	-	-	-	-	-
N1A	-	-	126	131	136	162	168	188	195	-	-	-	-	-	-	-	-	-	-
N1B	-	-	-	-	-	-	271	286	298	348	-	-	-	-	-	-	-	-	-
N1C	-	-	-	-	-	-	-	413	426	475	542	-	-	-	-	-	-	-	-
N1D	-	-	-	-	-	-	-	-	622	652	718	817	939	-	-	-	-	-	-
N1E	-	-	-	-	-	-	-	-	-	-	961	1054	1195	1390	1620	-	-	-	-
N1G	-	-	-	-	-	-	-	-	-	-	-	1874	2173	2378	2600	-	-	-	-
N1H	-	-	-	-	-	-	-	-	-	-	-	-	2268	2710	3980	5109	-	-	-
N1J	-	-	-	-	-	-	-	-	-	-	-	-	-	5100	5580	6680	-	-	-
N1M	-	-	-	-	-	-	-	-	-	-	-	-	-	-	-	-	11410	12018	12372

## 6.5 Attachment dimensions

### MOUNTING FACE DIMENSIONS WITH NELES BORE

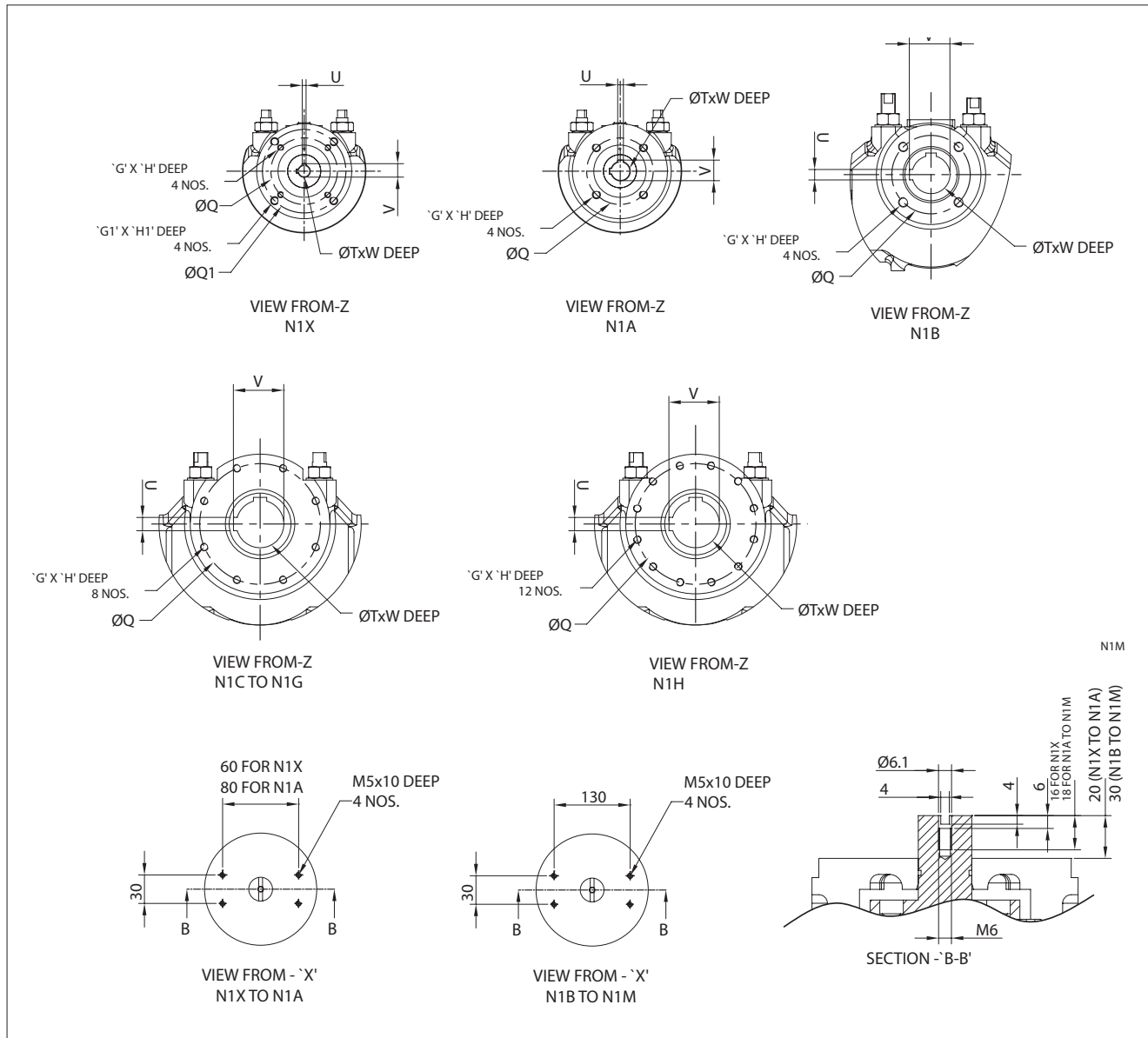

Actuator	Dimensions, mm										Mounting face
	G	G1	H	H1	Q	Q1	T	U	V	W	
N1X	M8	-	12	-	70	-	20	4.76	22.3	35	F07
	-	M10	-	15	-	102	20	4.76	22.3	35	F10
N1A	M16	-	24	-	140	-	40	9.53	44.4	68	F14
N1B	M20	-	30	-	165	-	70	19.05	78.3	173	F16
N1C	M16	-	24	-	254	-	95	22.23	105.0	202	F25
N1D	M20	-	30	-	298	-	105	25.40	116.3	217	F30
N1E	M30	-	45	-	356	-	135	31.75	149.0	309	F35
N1G	M36	-	54	-	406	-	180	44.45	199.4	383	F40
N1H	M36	-	54	-	483	-	200	50.80	222.1	385	F48

Note: More detailed dimensions with tolerances available in document F102307

# MOUNTING FACE DIMENSIONS WITH ISO BORE

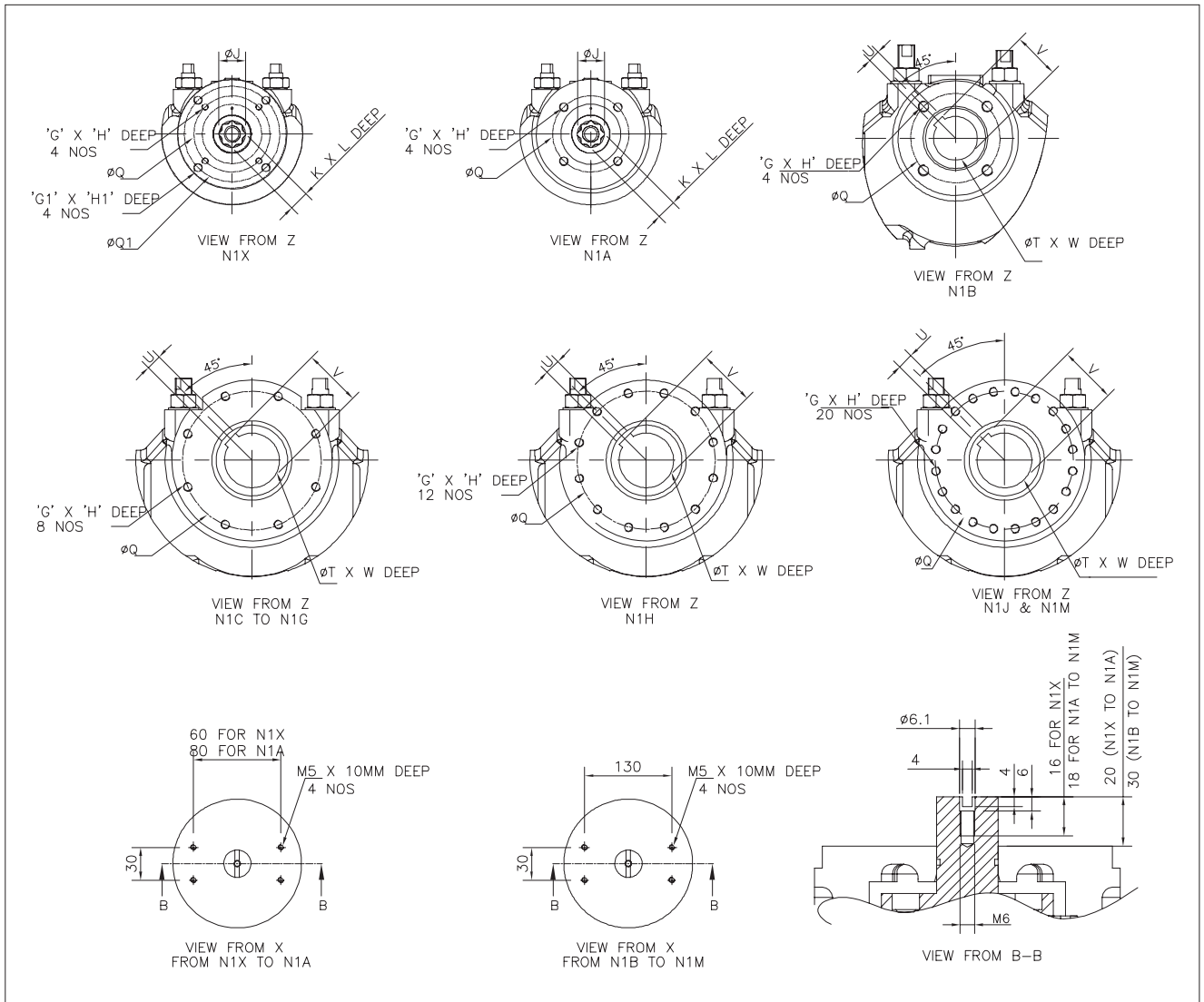

Actuator	Dimensions, mm													Mounting face
	G	G1	H	H1	ØJ	K	L	Q	Q1	T	U	V	W	
N1X	M8	-	12	-	30.5	22	25	70	-	-	-	-	-	F07
	-	M10	-	15				-	102	-	-	-	-	-
N1A	M16	-	24	-	48.2	36	45	140	-	-	-	-	-	F14
N1B	M20	-	30	-	-	-	-	165	-	80	22	85.4	173	F16
N1C	M16	-	24	-	-	-	-	254	-	100	28	106.4	202	F25
N1D	M20	-	30	-	-	-	-	298	-	120	32	127.4	217	F30
N1E	M30	-	45	-	-	-	-	356	-	160	40	169.4	309	F35
N1G	M36	-	54	-	-	-	-	406	-	178	45	188.4	383	F40
N1H	M36	-	54	-	-	-	-	483	-	220	50	231.4	385	F48
N1J	M36	-	54	-	-	-	-	603	-	280	63	292.4	483	F60
N1M	M42	-	75	-	-	-	-	724	-	336	80	351.4	556	-

Note: More detailed dimensions with tolerances available in document F102307.

## N1 Actuator Details with Manual Overrides

N1 Actuator with Straight Handwheel Dimension details, mm:

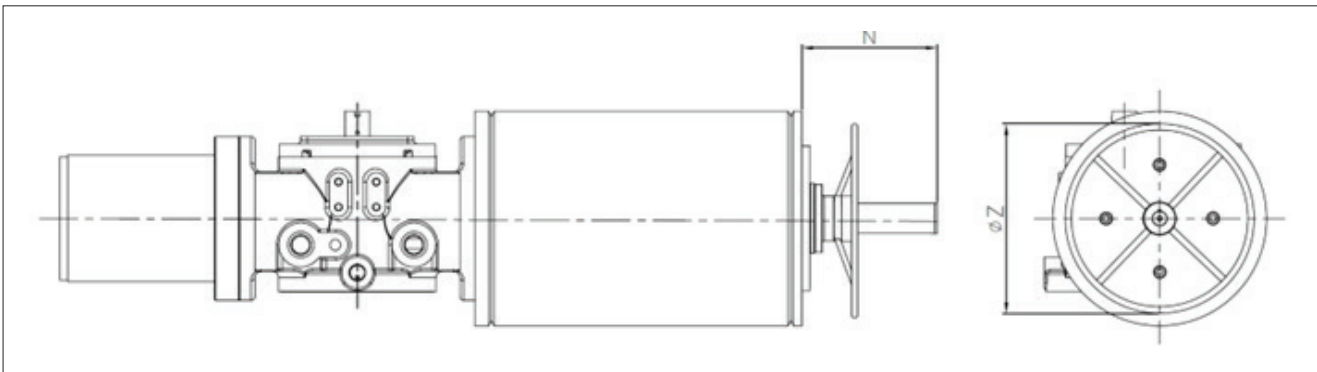

MODEL	N	Z
N1X0063 - 0125	142.5	300
N1A0100 - 0125	219	300

N1 Actuator with Side Handwheel Dimension details, mm:

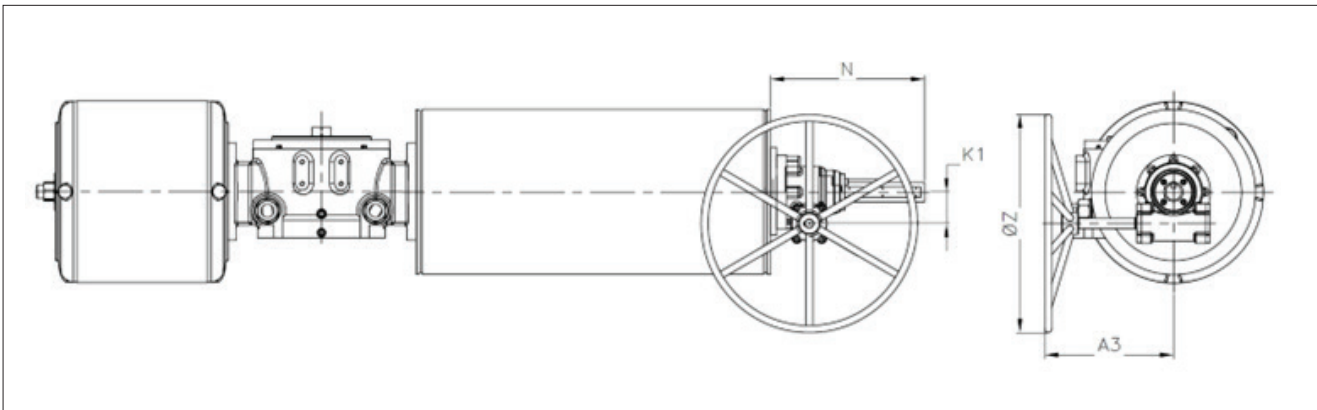

MODEL	N	Z	K1	A3
N1A0150 - 0250	299	290	51	222
N1A0300 - 0350	351.5	500	72	297.5
N1B0250	337	290	51	222
N1B0300 - 0400	389.5	500	72	297.5
N1C0300 - 0400	425	500	72	297.5
N1C0500	471	650	118.3	296.7

N1 Actuator with Spring Return Manual Override dimensions, mm

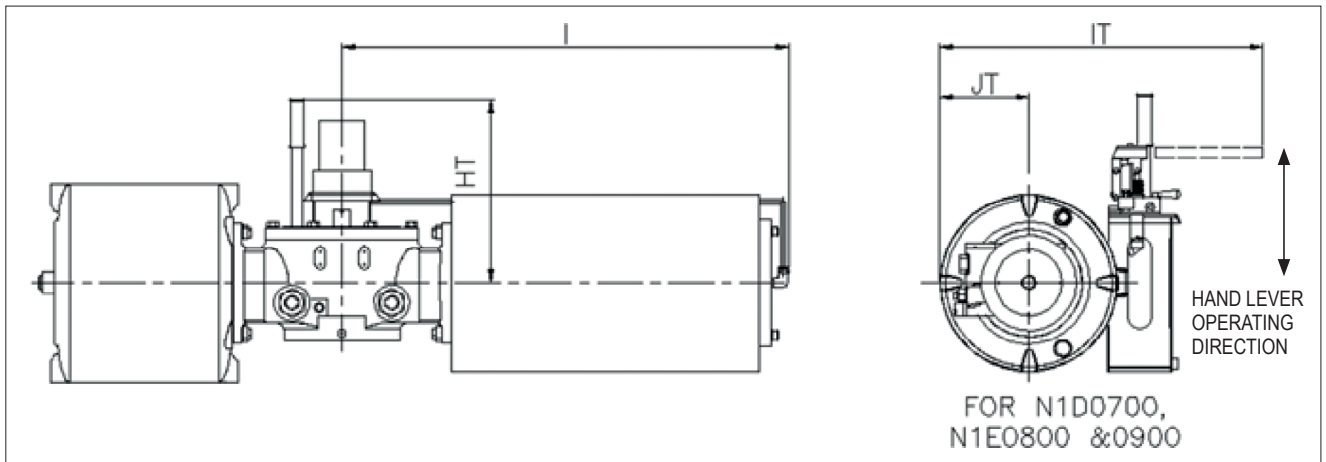
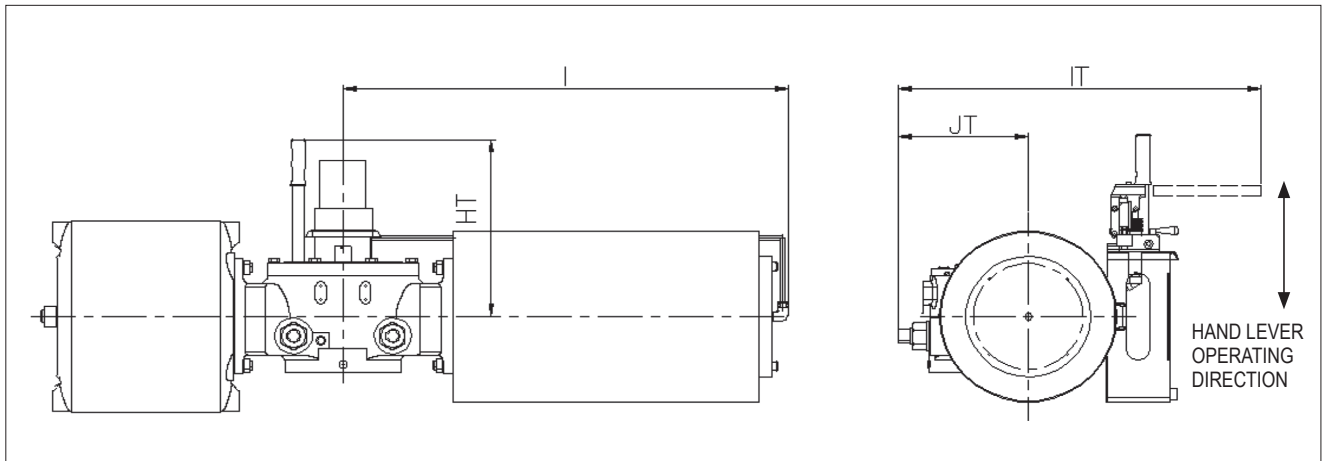

MODEL	I	IT	JT	HT
N1C0300 - 0500	1110	891	252	574
N1D0350 - 0600	1337	975	321	559
N1D0700	1337	1009	321	559
N1E0500 - 0700	1623	993	368	525.5
N1E0800 - 0900	1623	1208	368	525.5
N1G0600 - 0900	2440	1132	444	503
N1H0700E3-0900E3	2010	1301	549	530
N1H0800E2-0900E2	2450	1301	549	530
N1H0900E1	2683	1301	549	530
N1H1000-E1	2683	1316	549	530
N1H1000-E2	2450	1316	549	530
N1H1000-E3	2010	1316	549	530
N1J0800 - 01000	2948	1637	677	565
N1M1100-1300	3135	850	899	750

Note:

- \* The recommended hand pump mounting position is as shown in the above figure, with the pump oriented vertically downward and the hand lever positioned in the top direction (pumping operation from top to bottom).
- \* For applications requiring a non-recommended orientation, the hand pump assembly will be supplied separately.

## Actuator with Double Acting Manual Override dimensions, mm

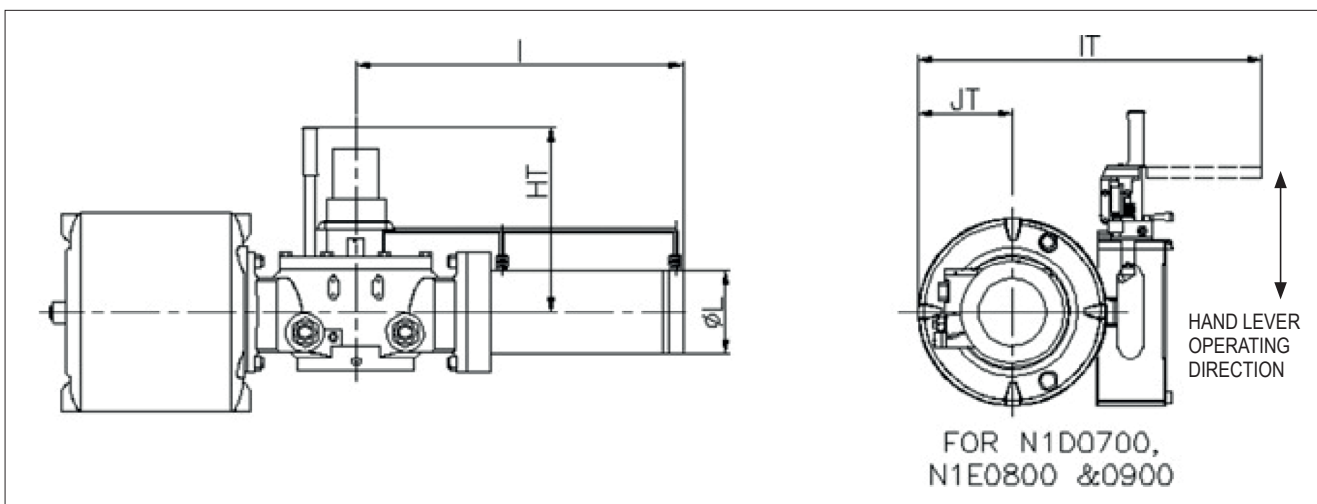
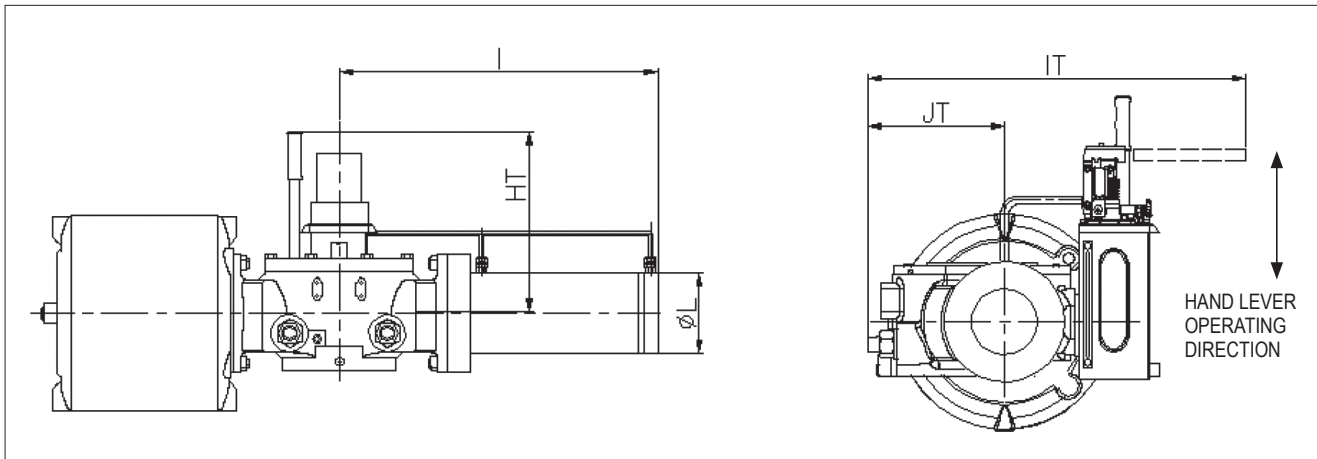

MODEL	I	IT	JT	L	HT
N1C0300 - 0500	635	891	252	150	574
N1D0350-0600	818	975	321	150	559
N1D0700	818	1017	321	150	559
N1E0500-0700	866	801	368	200	525,5
N1E0800	866	1208	368	200	525.5
N1E0900	866	1258	368	200	525.5
N1G0600 - 0900	1049	1132	444	200	503
N1H0700-1000	1293	1299	549	200	530
N1J0700-1000	1631	1637	677	250	565
N1M1000-1300	2082	1637	899	300	565

### Note:

- \* The recommended hand pump mounting position is as shown in the above figure, with the pump oriented vertically downward and the hand lever positioned in the top direction (pumping operation from top to bottom).
- \* For applications requiring a non-recommended orientation, the hand pump assembly will be supplied separately.



## EU DECLARATION OF CONFORMITY



**Manufacturer:**

Valmet Flow Control Private Limited  
E-61, Additional MIDC Area, Anand Nagar,  
421506 Ambarnath (East)  
Maharashtra, India

EU Authorised Representative: Valmet Flow Control Oy, Vanha Porvoontie 229, 01380 Vantaa, Finland.  
Contact details: [+358 10 417 5000](tel:+358104175000)

Product:	Pneumatic actuator
Type:	N1-series (Scotch-Yoke)
ATEX group and category:	⊕ II 2 GD
Protection concept of non-electrical equipment	
80°C:	Ex h IIC T6 Gb/ Ex h IIIC T85°C Db
125°C:	Ex h IIC T6...T4 Gb/ Ex h IIIC T85°C...T120°C Db

ATEX 2014/34/EU Annex VIII technical files are archived by Notified Body number 0598.

**Manufacturer's certificates:**

Standard / Directive	Notified Body and NoBo number	Certificate No.
ISO 9001:2015	LRQA (Certification body)	10531829
PED 2014/68/EU Module D	DNV Business Assurance Italy S.r.l. 0496	C537054
PED 2014/68/EU Module B	DNV Business Assurance Italy S.r.l. 0496	10000442664-PA-ACCREDIA-FIN
ATEX 2014/34/EU Annex IV	DNV Product Assurance AS Norway 2460	Presafe 18 ATEX 91983Q Issue 6

**Applicable directives:**

PED 2014/68/EU Category IV	Pressure equipment
Machinery 2006/42/EC Annex IIB	Actuator
ATEX 2014/34/EU	Non-electrical equipment

As the products within our sole responsibility of design and manufacture may be used as parts or components in machinery and are not alone performing functions as described in Article 6(2) of Machinery Directive 2006/42/EC, we declare that our product(s) to which this Declaration of Conformity relates must not be put into service until the relevant machinery into which it is to be incorporated has been declared in conformity with the provisions of the Machinery Directive.

The product above is manufactured in compliance with the applicable European directives and technical specifications/ standards. The product is in conformity with the customer order.

Non-electrical equipment is according EN 80079-37:2016 and EN 80079-36:2016. The actual surface temperature of non-electrical equipment is depended on the process and ambient conditions (EN 80079-36:2016 § 6.2.5 and 6.2.7). The protection from high or low temperature must be considered by the end user before put into service.

Protection from e.g. static electricity caused by the process or connected equipment must be considered by the user (EN 60079-14 § 6). Follow the caution instruction in identification plate sticker and instruction manual.

The product does not possess any residual risk according to hazard analysis conducted under the applicable directives providing that the procedures stated by the IMO (Installation, Maintenance and Operating) instructions manual are followed and the product is used under conditions mentioned in the technical specifications.

Ambarnath

16.9.2024

Ashok Hosakeri, Senior Quality Manager

## 7. TYPE CODE

Heavy duty scotch yoke actuator										
1.	2.	3.	4.	5.	6.	7.	8.	9.	10.	11.
N1	B	0250	S	1	G	E03	C	N	/	*(NIL)

1.	Series
N1	Neles heavy duty actuator

4.	Link type
S	Symmertric

2.	Frame size
B	X
	A
	B
	C
	D
	E
	G
	H
	J
	M

5.	Cylinder type
1	Single cylinder

6.	Temperature range
G	-20°...+80° C / -4° ... 176° F
H	-20°...+125° C / -4° ... 257° F
A	-55°...+80° C / -67° ... 176° F

7.	Single / Double acting
E01 ... E11	Single acting
D00	Double acting

3.	Cylinder size, mm	Available frame
0250	0063	X
	0080	X
	0100	X, A
	0125	X, A
	0150	A
	0200	A
	0250	A, B
	0300	A, B, C
	0350	A, B, C, D
	0400	B, C, D
	0500	C, D, E
	0600	D, E, G
	0700	D, E, G, H, J
	0800	E, G, H, J
	0900	E, G, H, J
	1000	H, J, M
	1100	M
	1200	M
	1300	M

8.	Spring action
C	Spring to close
A	Spring to open
D	Double acting

9.	Shaft bore-key type
N	Neles bore, female double key way
D	ISO bore, female keyway.

10.	Break
-	Type code break to be left blank if no options specified

11.	Options
HW	Handwheel, manual override
HP	Hydraulic, manual override



**Valmet Flow Control Private Limited**  
E-61, Additional MIDC Area, Anand Nagar,  
421506 Ambarnath (East)  
Maharashtra, India  
[www.valmet.com/flowcontrol](http://www.valmet.com/flowcontrol)

Subject to change without prior notice.  
Neles, Neles Easyflow, Jamesbury, Stonel, Valvcon and Flowrox, and  
certain other trademarks, are either registered trademarks or trademarks of  
Valmet Oyj or its subsidiaries in the United States and/or in other countries.

