

Manual valve gear

Series M

Installation, maintenance and
operating instructions



Table of contents

GENERAL	3
Preface	3
Technical data	3
Handling and safety precautions	3
ATEX	3
INSTALLATION	3
Mounting to the valve	3
Adjustment of the setscrews	4
OPERATING INSTRUCTIONS	5
MAINTENANCE	5
ASSEMBLY DRAWING AND PARTS LIST	6
DIMENSIONS	7
TYPE CODE	8

Subject to change without notice.

All trademarks are property of their respective owners.

READ THESE INSTRUCTIONS FIRST!

These instructions provide information about safe handling and operation of the valve.

If you require additional assistance, please contact the manufacturer or manufacturer's representative.

SAVE THESE INSTRUCTIONS!

Addresses and phone numbers are printed on the back cover.

1. GENERAL

1.1 Preface

The gearbox of the M-series is a quarter turn gearbox intended to be used for the manual operation of valves (e.g. butterfly valves) in pipelines.

NB. This manual is valid only for the standard M-series gearboxes of Neles. For special versions, specifications and model can differ. Valmet is not responsible for any damage caused by incorrect use of the gearbox.

1.2 Technical data

Specifications

The maximum allowable input and output torque are listed in the Table 1.

Table 1 Connection data of the gearbox

Gearbox type	Connection Valve	Max. Torque [Nm]	
	ISO 5211/1	Input	Output
M07	F05-F07-F10	29	330
M10	F05-F07-F10	43	500
M12	F10-F12	83	1000
M14	F10-F12-F14-F16	152	2000
M15	F10-F12-F14-F16	171	3250
M16	F16-F25	136	4500
M25	F16-F25	305	8400

This gearbox is applicable to valve shafts with keyway only.

For more specified information, you can contact our sales department.

1.3 Handling and safety precautions

Be sure to read and understand this manual before installation and use of our gearboxes.

Storage

The gearboxes need to be stored in a safe way to avoid accidents. Also avoid storage in areas subjected to high temperature extremes and /or areas subjected to large amounts of humidity and dust.

Handling

Never drop the gearbox or otherwise subject it to strong impact.

Correct use

Prior to installation, be sure the gearbox will NOT be overloaded during normal use. For this, convince yourself the valve size and needed opening torque do not exceed the values given for the gearbox. For the maximum allowable torque on the gearbox, see Table 1.

Installation and operating

Not observing the rules as stated in this manual, can lead to damage and / or personal injuries. The qualified personnel must be fully aware of the instructions as described in this manual.

Only when the instructions are observed, correct operation of the gearboxes can be guaranteed.

Disposal

Never refuse a gearbox at a general disposal unit. The gearbox has to be offered to a disposal depot for recycling. The iron parts can be used for recycling. The seals are of nitrile and can be used for plastic recycling.

The grease may not be discharged to sewer- or surface water. It has to be disposed according to local regulations for incineration.

1.4 ATEX

Your gearbox can be supplied with a label with following markings:



This means that the gearbox meets the ATEX-directive 94/9/EG



This product is fabricated conform the procedure related to internal control of production with regards to the safety aspects.



This product meets the requirements for explosion prevention

II

In a potential explosive surrounding, other than in mines,

2

With a high level of safety, based on normal operation and anticipated risks

GD

Suitable for a possible explosive atmosphere caused by gases, vapours, mists of air/dust mixtures

c

Safety obtained by constructive solutions.

2. INSTALLATION

2.1 Mounting to the valve

Following description applies to standard type gearboxes.

1. The gearbox is standard delivered in the closed position.
2. It is recommended to mount a handwheel on the input shaft before assembling the gearbox to the valve, Figure 1.

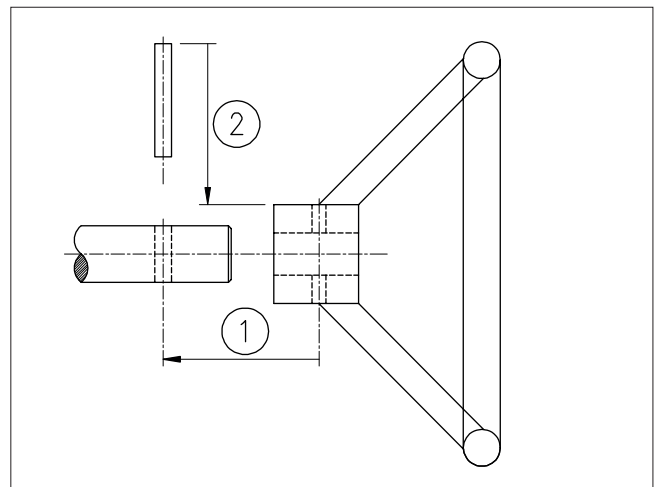

Fig. 1 Mounting handwheel

3. Check if the boltcircle of the flanges (of gearbox and valve) coincide. Also check if the valve stem and the bore of the gearbox match.

4. Make sure the valve is in the closed position. If not, close the valve before continuing.
5. Check if the gearbox is in fully closed position by turning the handwheel clockwise.
6. In case of use of studbolts for fixing the gearbox to the valve, it is recommended to screw them into the bottomflange of the gearbox before mounting the gearbox on top of the valve.
7. Coat the valve stem and outer surface of the bushing (2) and actuator bore with a suitable grease to aid fitting. The plate (21) should be installed, when the bushing (2) is used, between the valve flange mounting face. This plate locks up the insert.
8. Mount the gearbox perpendicular to the valve (see Figure 2).
9. Fix the gearbox to the valve with nut and ring. In case of use of bolts, for the maximum screwdepth, see Table 2. For tightening, refer to standard VDI 2230.
10. The assembly is now ready for adjustment (see Chapter 2.2).

Table 2 Max. screw depths

Mounting	F05	F07	F10	F12	F14	F16	F25
Max. screw depth	8	11	13	16	18	18	18

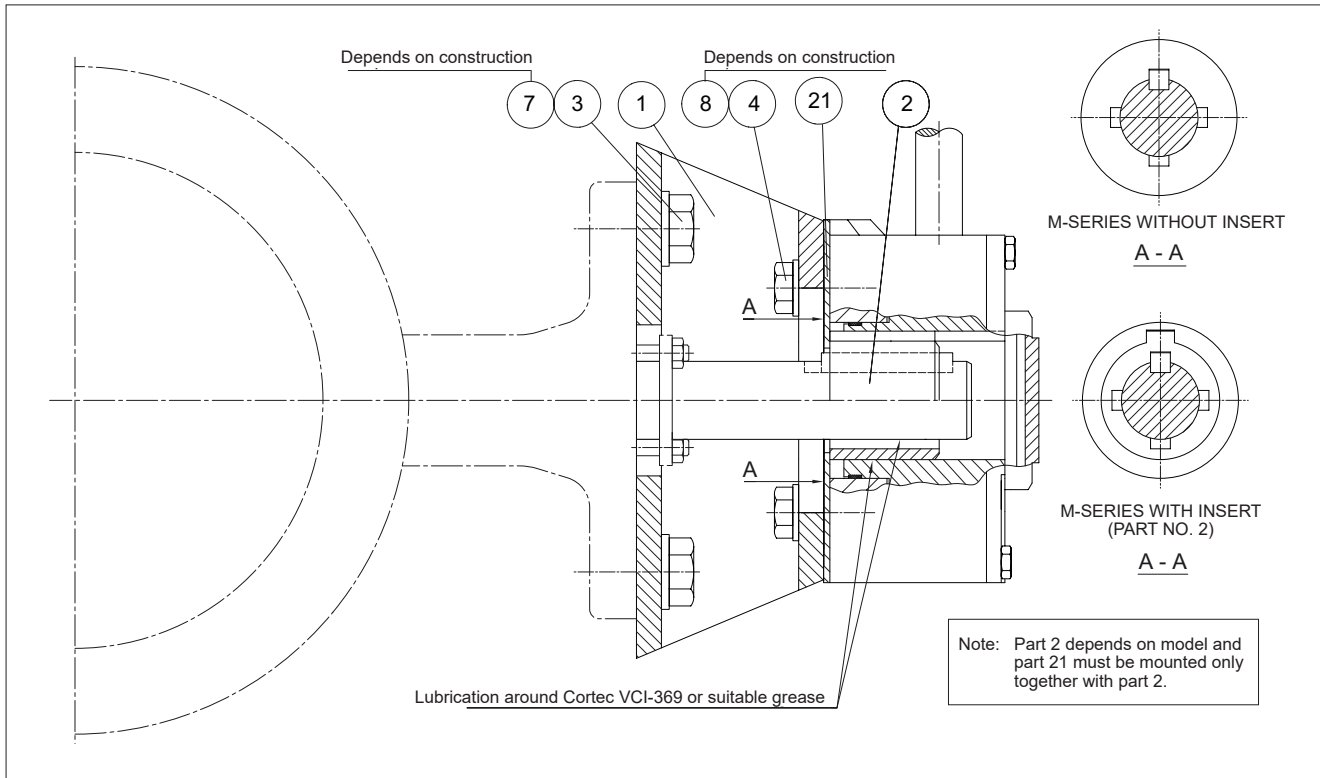

Fig. 2 Gearbox perpendicular to the valve

2.2 Adjustment of the setscrews

The gearbox is mounted on top of valve (see installation).

1. Close the valve totally, by turning the handwheel clockwise.
2. The valve position is indicated by the arrow on the position indicator.
3. Remove the plastic caps from the setscrews.
4. When the fully closed position can not be achieved, loosen the setscrew-close (see Figure 3) by turning them counterclockwise. Continue turning the handwheel until the valve is totally closed. Please note, that the butterfly valves need to be closed using a given torque, see the tables in a relevant valve manual.
5. Screw the set-screw back into the gearbox (by turning clockwise) until blocked. Secure the setscrew- close with the nut.
6. Open the valve by turning the handwheel counterclockwise.
7. When it can not be achieved to open the valve totally (90°), loosen the setscrew-open (see Figure 3) by turning it counterclockwise. Continue turning the handwheel until the valve is totally opened.
8. Screw the set-screw back into the gearbox (by turning clockwise) until blocked. Secure the setscrew- open with the nut.
9. Close the valve with the handwheel
10. Put the plastic caps back on the setscrews.
11. Adjustment completed.

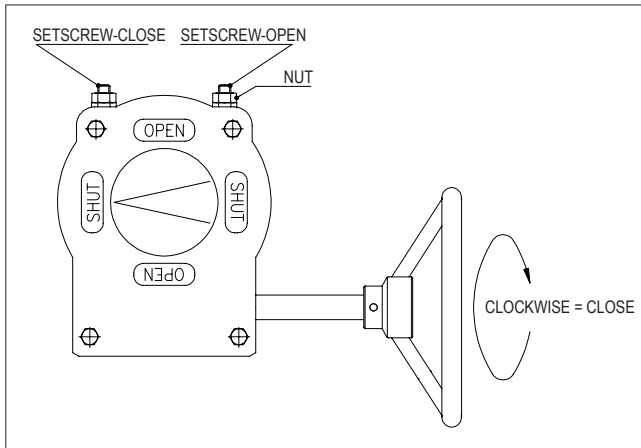

Fig. 3 Gearbox setscrew adjustment

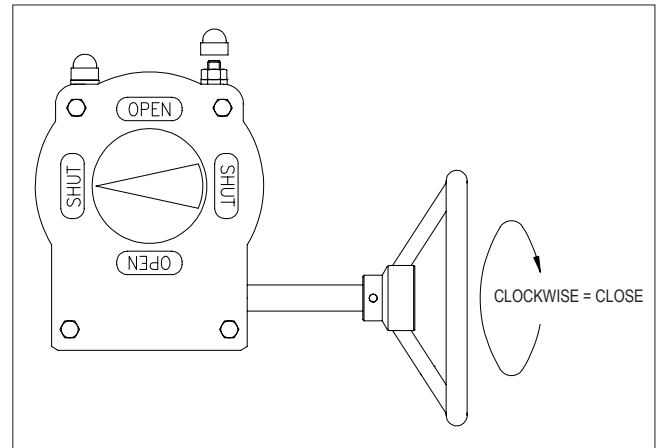

Fig. 4 Gearbox, series M

3. OPERATING INSTRUCTIONS

The series M gears are manually operated quarterturn gearboxes made of cast iron.

The maximum allowable input- and output torques are mentioned in Chapter 1.2.

1. The gearbox is manually operated by handwheel.
2. For opening the valve, the handwheel is turned counterclockwise. Closing is clockwise.
3. Stop turning when the required valve position is achieved. The number of turns needed from totally open to totally close the valve is in Table 3.
4. The valve position is indicated by the position indicator on top of the gearbox.
5. When the valve can not be totally opened (or closed), first detect and solve the cause of malfunction.
6. In case of malfunction of the gearbox, this one has to be replaced (see chapter installation for dismounting). Return the gearbox to your supplier for repair.
7. When you do the repair in house, all replacement parts must be obtained from the manufacturer to assure proper operation of the gearbox.
8. The gearbox is self-braking. Therefore no fixation needs to be installed to retain the valve position.
9. When the fault is repaired, turn the handwheel until blocked.
10. The system is ready for use.

Table 3 No. of turns for totally open/closed

Manual gear	Turns
M07	9,25
M10	9,25
M12	8,5
M14	9,5
M15	13,75
M16	27
M25	19,5

4. MAINTENANCE

Under normal conditions, the gearbox is maintenance free.

The series M gearboxes can be used at ambient temperatures from -20 to +120 °C.

The standard gearbox reaches IP67 (dust- and waterspray proof). Cleaning can be done with a waterhose, not a high pressure waterjet.

5. ASSEMBLY DRAWING AND PARTS LIST

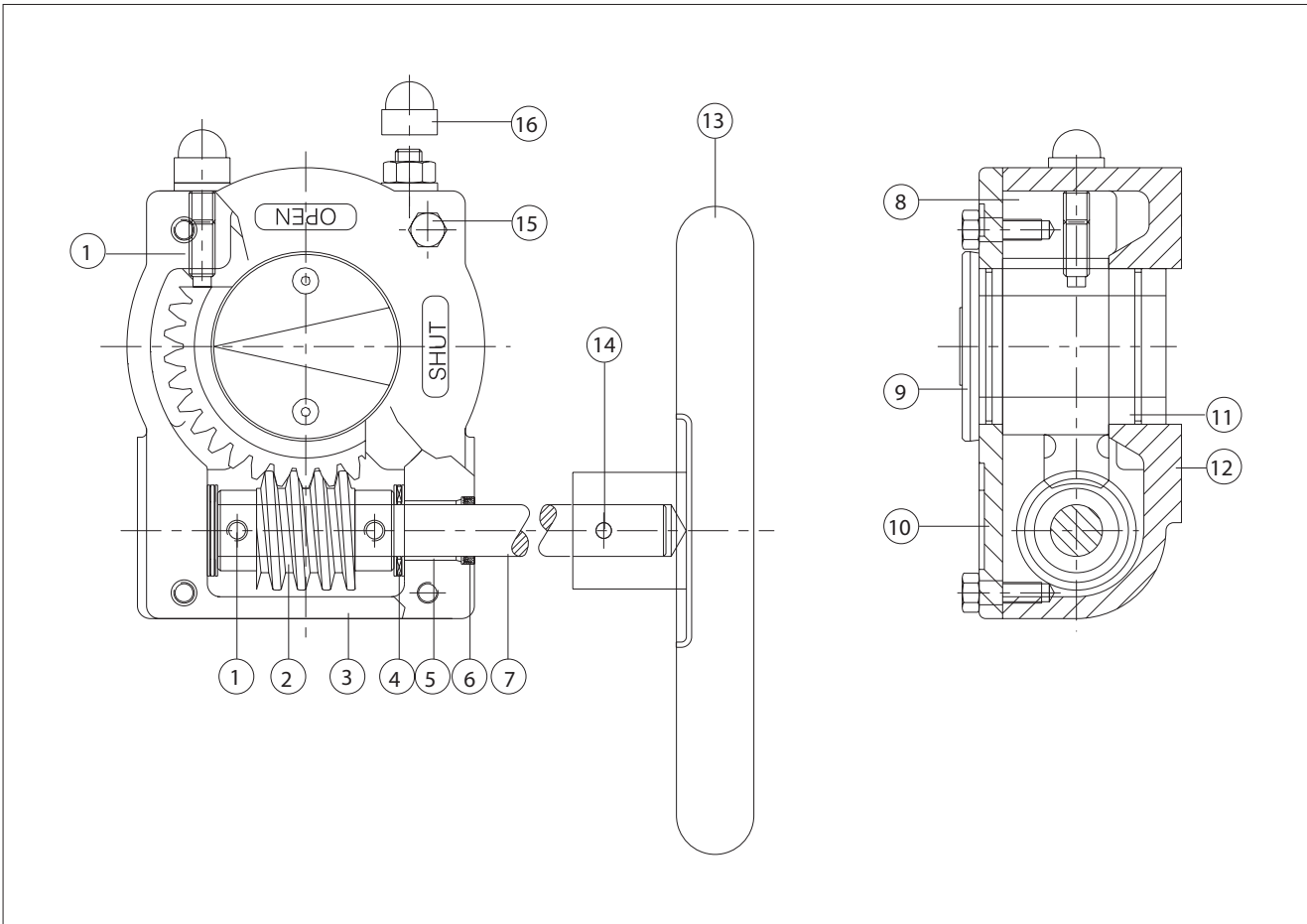

Item	Qty.	Description
1	2	Set-screw
2	1	Worm
3	1	Gasket
4	1	Needle-Bearing
5	1	Bushing
6	1	Oil-seal
7	1	Shaft
8		Grease
9	1	Position indicator
10	1	Coverplate
11	1	Quadrant
12	1	Body
13	1	Handwheel
14	1	Spring type straight pin
15	4	Hexagon head screw
16	2	Head cap screw

6. DIMENSIONS

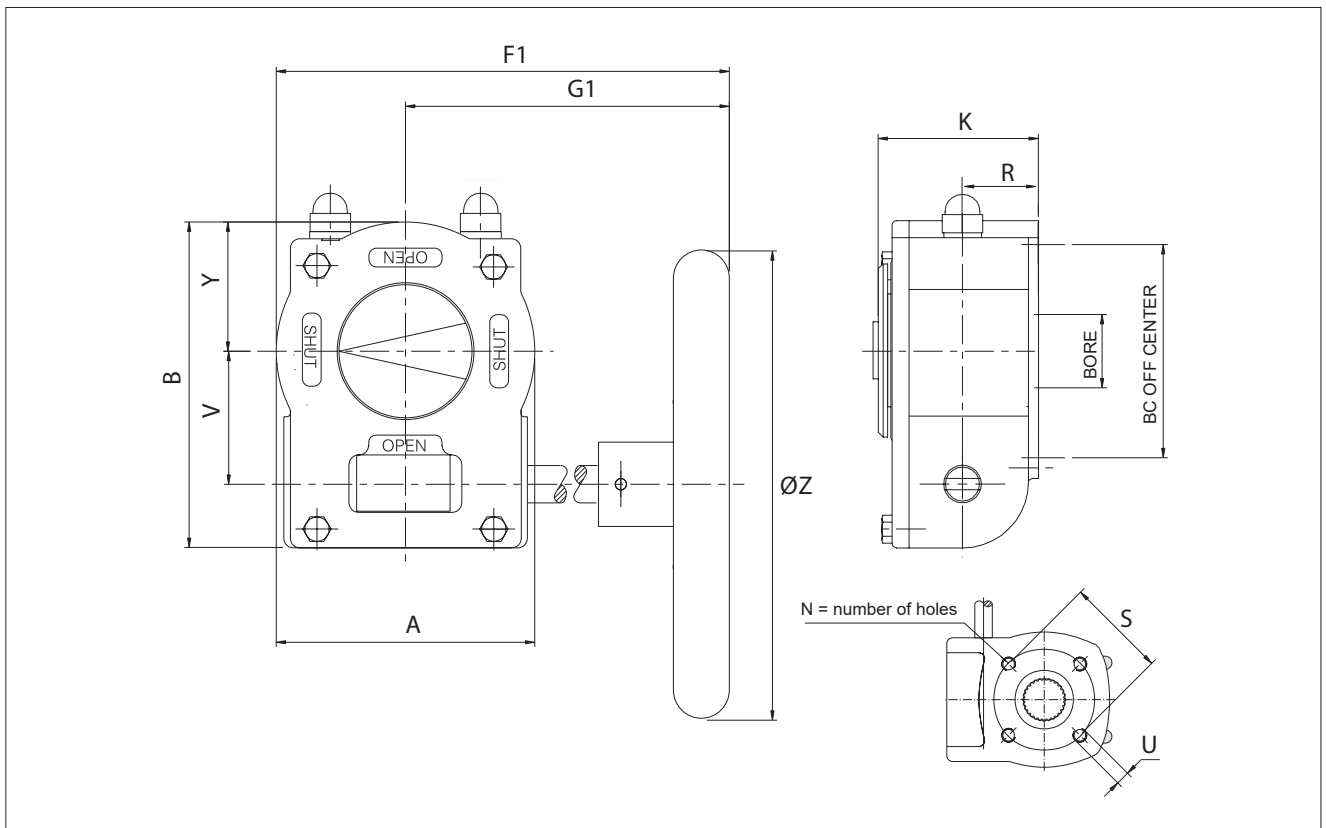

Unit size	Bore size	Valve mounting flange ISO 5211	Dimensions, mm										S	N, no. of holes	U, dia	U, depth	Hand wheel dia Ø/ type	Weight kg / lbs
			G1, with std input shaft	F1, with std input shaft	A	B	V	Y	K	R	Max. stem height	Ød, max valve shaft dia						
M07	insert 15	F05+F07+F10	185	241	102	124	52	44	64	28,6	45	15	50, 70, 102	4,4,4	M6, M8, M10	8, 11, 13	160/R6	3.8 / 7.7
M07	straight 20 or 25	F05+F07+F10	185	241	102	124	52	44	64	28,6	54,5	25	50, 70, 102	4,4,4	M6, M8, M10	8, 11, 13		
M10	straight 20 or 25	F05+F07+F10	187	243	102	124	52	44	64	28,6	54,5	25	50, 70, 102	4,4,4	M6, M8, M10	8, 11, 13	200/R8	4.3 / 7.7
M12	insert 25 or 30	F10+F12	235	304	138	174	71	69	88	40,5	79	30	102, 125	4,4	M10, M12	13, 16	315/R12	10.0 / 18.7
M12	straight 35	F10+F12	235	304	138	174	71	69	88	40,5	79	35	102, 125	4,4	M10, M12	13, 16		
M14	insert 35 or 40	F12+F16	305	405	200	226	86	100	93	42	82	40	125, 165	4,4	M12, M20	16, 18	400/R16	18.2 / 30.9
M14	straight 45	F12+F16	305	405	200	226	86	100	93	42	82	45	125, 165	4,4	M12, M20	16, 18		
M14	insert 35 or 40	F10+F14	305	405	200	226	86	100	93	42	82	40	102, 140	4,4	M10, M16	13, 16		
M14	straight 45	F10+F14	305	405	200	226	86	100	93	42	82	45	102, 140	4,4	M10, M16	13, 16		
M15	straight 35, 40, 45, 50 or 55	F10+F14	346	456	220	258	105	110	102	48	91	55	102, 140	4,4	M10, M16	13, 18	500/R20	26.2 / 48.5
M15	straight 35, 40, 45, 50 or 55	F12+F16	346	456	220	258	105	110	102	48	91	55	125, 165	4,4	M12, M20	16, 18		
M16	insert 45, 55	F16+F25	348	491	285	300	53	142	120	56	111	55	165, 254	4, 8	M20, M16	18, 18	600/R24	31.8 / 71.1
M16	straight 65 or 70	F16+F25	348	491	285	300	53	142	120	56	111	70	165, 254	4, 8	M20, M16	18, 18		
M25	straight 70, 75 or 85	F16+F25	412	597	370	402	182	170	160	59	121	85	165, 254	4, 8	M20, M16	18, 18	600/R24	60.8 / 123.5

7. TYPE CODE

Manual gear operator, series M				
1.	2.	3.	4.	5.
M	10/25	F10	R8	-

1.	PRODUCT GROUP
M	Manual gear operator with attachment dimensions acc. to ISO 5211, VDI/VDE 3845 mounting surface.

2.	SIZE
	E.g. 10/25 = actuator size / shaft bore diameter 07/15, 07/20, 07/25, 07/D11*, 07/D14* 10/20, 10/25 12/25, 12/30, 12/35 14/35, 14/40, 14/45 15/35, 15/40, 15/45, 15/50, 15/55 16/45, 16/50, 16/55, 16/65, 16/70 25/70, 25/75, 25/85

*) D11= square EN ISO 5211 Diagonal
D14= square EN ISO 5211 Diagonal

3.	VALVE MOUNTING FLANGE, ISO 5211 TYPE
F05, F07, F10	For M07/15, M07/20, M07/25
F10	For M10/20, M10/25
F12	For M12/25, M12/30, M12/35
F14	For M14/35, M14/40, M14/45
F12, F16	For M14/35, M14/40, M14/45
F14	For M15/35, M15/40, M15/45, M15/50, M15/55
F16	For M15/35, M15/40, M15/45, M15/50, M15/55
F16, F25	M16/45, M16/55, M16/65, M16/70
F16, F25	For M25/75, M25/85

4	OPERATION **)
R6	Handwheel for M07
R8	Handwheel for M10
R12	Handwheel for M12
R16	Handwheel for M14
R20	Handwheel for M15
R24	Handwheel for M16
R24	Handwheel for M25

***) Ensure the selection of the handwheel from technical bulletin 6MG21 (new)

5.	SPECIAL CONSTRUCTION
-	Standard without sign. ISO 5211 mounting face. Temperature range -20 to +120 °C / -4 to +250 °F. Two mechanical stop screws.
E	Extended shaft for handwheel. Extension length has to be specified. Over +0.3 m extensions have to be supported by customers own solution.
V Obsolete	VDI/VDE 3845 mounting surface for accessories.
P	Padlock flange for handwheel
C	Chain wheel
CT	Low temperature version down to -55 °C / -65 °F
HT	High temperature grease up to +160 °C / +320 °F
OX	Oxygen grease, temperature range -20 to +80 °C
Y	Special construction

Subject to change without prior notice.

Neles, Neles Easyflow, Jamesbury, Stonel, Valvcon and Flowrox, and certain other trademarks, are either registered trademarks or trademarks of Valmet Oyj or its subsidiaries in the United States and/or in other countries.

Valmet Flow Control Oy

Vanha Porvoontie 229, 01380 Vantaa, Finland.

Tel. +358 10 417 5000.

www.valmet.com/flowcontrol

