

Neles™ Omega™ globe valves

Series GM

The series GM, Omega trim valves are most suitable for high pressure drop applications of both compressible and incompressible fluids as it enables the flow velocity to be controlled through the multistage Omega trim. Also, series GM range of valves combines high integrity features, such as 2 or 3 dimensional flow path multistage trim, a high flow capacity and a wide range of 'OMEGA' trim designs. This means it is ideally suited to meet the various severe service process control requirements that are demanded from a wide range of industry related applications. The 'OMEGA' trim design is a multi-passage, multiturn disk stack trim. There are 2-32 turns designs available depending on pressure drop and potential for cavitation. The fluid passes through the flow passage generated by the Omega multistage trim. The pressure drop is staged across the stacks so that the pressure drop progressively reduces as it passes through the steps of the trim. This gives excellent resistance to cavitation on high pressure drop applications. Standard valves are equipped with VD spring diaphragm actuators, VB or VC cylinder actuators with Neles™ intelligent valve controllers for precise flow control, extended operational life and performance monitoring on-line.

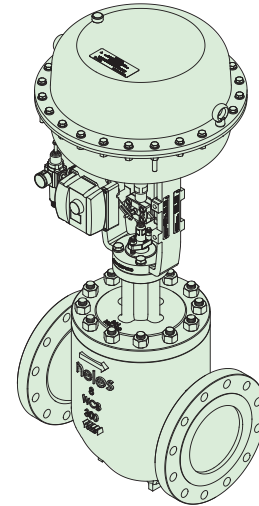

Construction

- Various construction design available with a range of different end styles and connections
- The Omega standard balanced trim design is based on 2 or 3 dimensional multistage cage and balanced plug.
- The multistage trim shape defines the flow path through the valve and flow characteristics of the valve (linear, equal percentage or others), standard trim characteristic is linear.
- The balancing holes are located in the top of the plug. This trim is specially suited to high pressure drop application and is used in the majority of control applications.
- Wide variety of trims with different Cv and characteristics
- Both metal and soft seats are available depending the application
- Optional bellows seal for toxic or other applications where no stem seal leakage is allowed
- Wide material selection for different applications
- Many end connection styles available for different applications
- Extension bonnet design for wide temperature range

Wide range of applications

- Suitable for gas, liquid and steam
- Wide temperature ranges from -196 ... +593 °C (-320 ... +1099 °F) with different bonnet constructions. Temperature limits -29 ... +425 °C / (-20 ... +797 °F) with standard bonnet construction, over +425 °C (+797 °F) and under -29 °C / (-20 °F) with extended bonnets
- Large variation of trim designs for multi-turns and passages for low-noise, and anti-cavitation applications
- Wide range of applicable noise control components, silencers, attenuate plates
- Inherently characterized trim offered in linear, and optionally equal percentage.
- Large range of trims per size allowing for wide rangeability in process conditions
- Clamped cage for heavy duty guiding on severe service applications
- High integrity cage guiding system
- Double packing available

Benefits of 'OMEGA' trim applications

- Quick change trim and top entry construction for easy in-line maintenance
- Self guided components makes for easy valve assembly
- All trim components removable from the top side for easy maintenance
- Prolonged trim and valve life time
- Effective noise control
- Reduction of cavitation damage and pipe fatigue
- Stable process control
- Faster start-up, reduced system managing cost
- Neles™ digital valve controller with online diagnostics enables performance follow up and predictive maintenance
- Efficient asset management with any FDT frame application and excellent networking capabilities

Accurate control & performance

- ND9000 digital valve controller for auto-calibration and accurate control
- Accurate and sensitive diaphragm and cylinder actuators
- Stable flow control with high rangeability
- Low-noise, anti-cavitation control and erosion resistant trims
- Streamline flow passage to secure capacity

Safety and quality

- Rugged one piece body structure to minimize leakage paths and make the valve less insensitive from prone stress
- Strictly tested to ensure specified performance with quality assurance systems in accordance to ISO 9001
- Certified ISO 15848 fugitive emissions
- Certified CE/PED & ATEX, TSG & EAC (GOST-R)
- Certified SIL (Safety Integrity Level) in accordance to IEC61508

Applications for 'OMEGA' trim

Severe services in power plant

- Flow control for main & start-up feed pump recirculation
- Main & booster feed water control
- Condensate booster pump recirculation
- Deaerator level control
- Turbine by-pass & steam generator blow down
- Auxiliary steam shoot blower control
- Boiler start-up main steam spray
- Pressurizer & POSRV
- Chemical & Volume Control System (CVCS) letdown
- HP coolant injection
- Atmospheric steam dump
- Atmospheric venting silencer

Severe services in oil & gas plant

- Compressor anti-surge, kick back & recycle
- Pump minimum flow & recirculation
- Blow down discharge to vent flare
- Reactor de-pressurization
- Turbo expander by-pass
- Gas injection lift control
- Gas storage pressure letdown
- Gas flow regulation
- Pipeline anti-surge
- Heavy oil letdown
- Ethylene letdown
- Steam vent to atmosphere
- Well head choke valves

Different trim designs

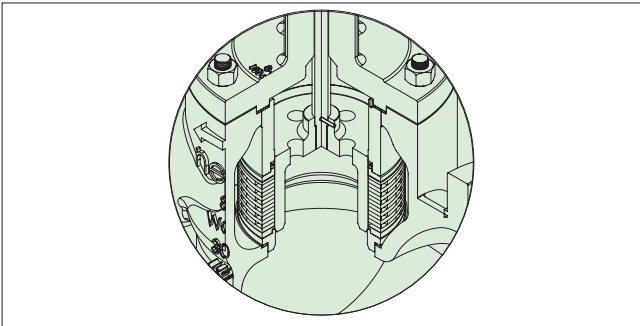

Omega quick change, Standard balanced trim

The Omega standard balanced trim design is based on 2 or 3 dimensional labyrinth disk stack cage and balanced plug. The opened disk stack shape defines the flow path through the valve and flow characteristics of the valve (linear, equal percentage, others), standard trim characteristic is linear. The balancing holes are located in the top of the plug. This trim is specially suited to high pressure drop application and is used in the majority of control applications.

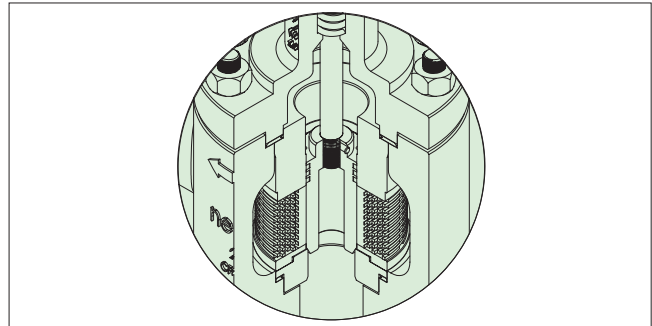

Multiple graphite seal rings, Omega trim

Multiple graphite seal ring construction is ideal solution for high temperature applications requiring FCI 70-2 Class III or IV tightness. It can be used in various high temperature applications, including high pressure service. The trim is compatible with both standard cage and Tendril trims.

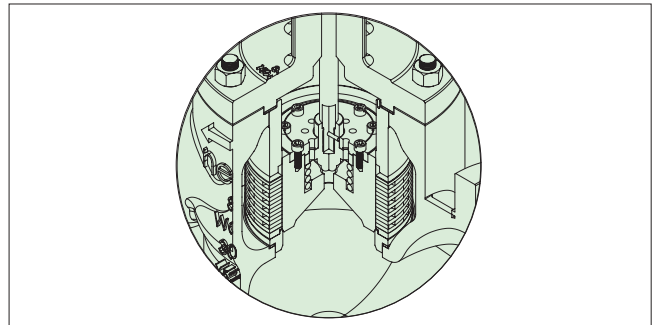

Omega quick change, Pilot balanced trim

Pilot balanced trim construction is designed with a special pilot plug & seat built-in the main plug. The design gives excellent seat tightness on high pressure drop and high temperature applications. The design applicable TSO (Tight shut off, seat leakage class V) requirement in high temperature services.

GM Application guide

Temperature range

PTFE + Graphite pressure energized seal with metal seat:	-56...+260 °C
PTFE + Graphite + Carbon pressure energized seal with metal seat:	-56...+320 °C
PTFE pressure energized seal with metal seat:	-196...+232 °C
Multiple graphite seals with metal seat:	-56...+540 °C
Pilot balanced trim with metal seat:	-56...+593 °C

Pressure energized seal ring construction

ANSI FCI 70-2 Class IV and V available with metal and soft seat.

Seal-ring & seat solutions for GM valve trims

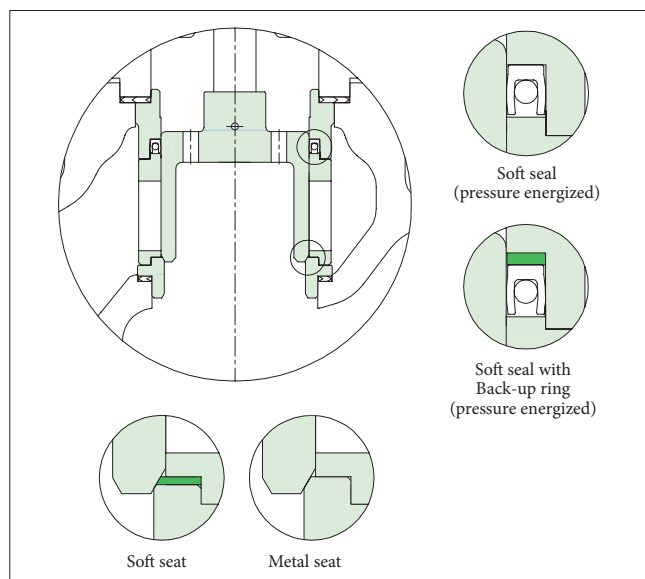

High temperature seal ring construction

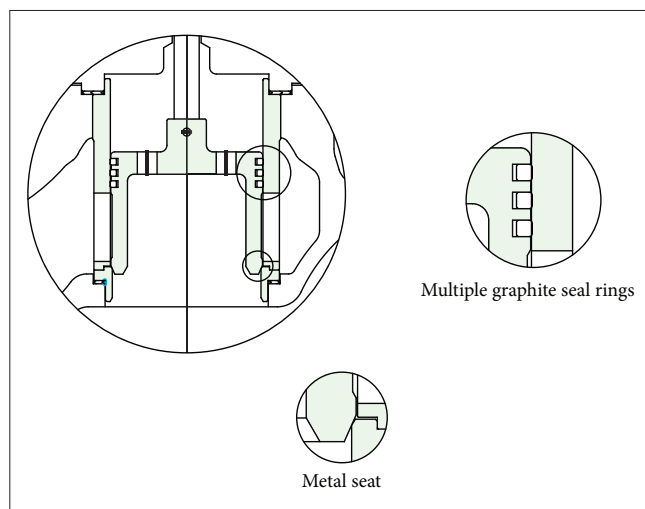

Temperature range with different body and stud/nut materials

Body, bonnet material	Stud, nut material	Temp. range (°C)	Sign
Carbon steel (WCB, A105)	ASTM A193-B7M STUD / ASTM A194-2HM NUT	-29...+425	G
Stainless steel (CF3, CF8, CF3M, CF8M)	ASTM A193-B8M / ASTM A194-8M NUT	-196...+425	D
Cr.Mo. Steel (WC6, F11, WC9, F22, C12A, F91)	ASTM A193-B16 STUD ASTM A194-4 NUT	-29...+593	H

Trim materials

GM, Trim				Temp. range (°C)	Sign
Plug	Stem	Seat	Disk		
SUS 420J2	XM-19	SUS420 J2	SUS420 J2	-10...+540	P2XVXS1P2X
CF8M + HCr	316 SS + HCr	CF8M	316L SS	-196...+425	T6XTCS1R4X
Inconel 625, 718, 750				-196...+645	*

* Please contact Valmet.

Gasket applications

Body, bonnet material	Gasket material	Temp. range (°C)	Sign
Carbon steel WCB, A105	S/W (Spiral wound) 316L + Graphite	-29...+425	S
Stainless steel CF8, CF8M, CF3, CF3M	S/W (Spiral wound) 316L + Graphite	-56...+425	S
	S/W (Spiral wound) 316L + PTFE	-196...+232	L
Cr.Mo. Steel WC6, WC9, F22, C12A, F91	S/W (Spiral wound) 316L + Hi-Graphite	-56...+593	H

Packing applications

Packing material	Temp. range (°C)	Pressure class	Sign
PTFE + Carbon fiber (Braided TEF + Graphite), standard	-196...+260	Up to CL900	G
PTFE V-Ring	-196...+232	Up to CL900	T
Graphite (with Mold + Braided)	-56...+400	Up to CL2500	F*
Hi-Graphite (with Mold + Braided)	-56...+593	Up to CL2500	H

* Graphite packing with low emission, live loaded construction can be applicable up to 425 °C.

Flow direction

Series	General plug (Balanced plug) & High temp balanced plug		Pilot balanced plug	Unbalanced plug
	Disk stack			
	General (Gas)	General (Liquid)	General	General
GM	FTO	FTC	FTC	FTO
AM	FTO	FTC	FTC	FTO

FTO: Flow to open
FTC: Flow to close

Cv ratio

100: 1

Flow characteristics

Linear, equal percentage or other customized characteristic.

GM, ratings & end connetions

Valve size DN / Inch	GM, ASME ratings										
	Class 150 ... 600				Class 900 ... 1500				Class 2500		
	RF	RTJ	SW	BW	RF	RTJ	SW	BW	RF	RTJ	BW
25 / 1	O	O	O	O	O	O	O	O		O	O
40 / 1-1/2	O	O	O	O	O	O	O	O		O	O
50 / 2	O	O	O	O	O	O	O	O		O	O
80 / 3	O	O		O	O	O		O		O	O
100 / 4	O	O		O	O	O		O		O	O
150 / 6	O	O		O	O	O		O		O	O
200 / 8	O	O		O	O	O		O		O	O
250 / 10	O	O		O	O	O		O		O	O
300 / 12	O	O		O	O	O		O		O	O
350 / 14	O	O		O	O	O		O		O	O
400 / 16	O	O		O	O	O		O		O	O

*Note 1. RF: Raised Face Flange, RTJ: Ring Joint, SW: Socket Weld, BW: Butt Weld.
 Bigger sizes are available, please contact Valmet.

GM, Components and materials

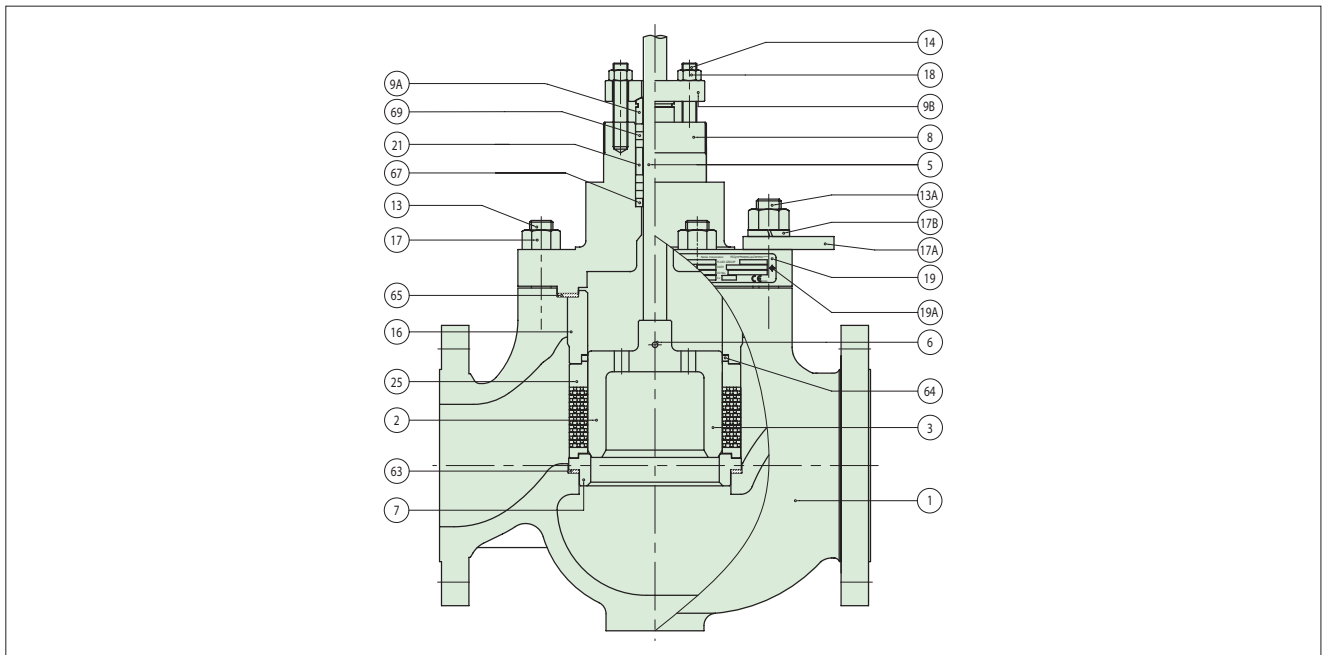

Body material: Carbon steel or alloy steel			Body material: Stainless steel	
Part no.	Description	Material	Material	Spare
1	BODY	A216 WCB / ALLOY STEEL AVAILABLE	A351 CF8M	
2	PLUG SET	420(J2) SS / 630 SS	316 SS / 316 SS	Cat 3
3*	PLUG	420(J2) STAINLESS STEEL	316 STAINLESS STEEL	
5*	STEM	630 STAINLESS STEEL + HCr	630 STAINLESS STEEL + HCr	
6*	PLUG PIN	316 STAINLESS STEEL	316 STAINLESS STEEL	
7	SEAT RING	420 STAINLESS STEEL	316 STAINLESS STEEL	Cat 3
8	BONNET	A216 WCB / ALLOY STEEL AVAILABLE	A351 CF8M	
9A	GLAND	304 STAINLESS STEEL	304 STAINLESS STEEL	
9B	GLAND FLANGE	A351 CF8	A351 CF8	
13 / 13A	STUD	A193 Gr.B7M	A193 Gr. B8M	
14	STUD	A193 Gr.B8M	A193 Gr. B8M	
16	CAGE GUIDE	420(J2) STAINLESS STEEL	420(J2) STAINLESS STEEL	Cat 3
17	HEXAGON NUT	A194 Gr.2HM	A194 Gr. 8M	
17A	LIFTING PLATE	JIS G3101-SS400	JIS G3101-SS400	
17B	SPRING WASHER	AISI 304	AISI 304	
18	HEXAGON NUT	A194 Gr.8M	A194 Gr. 8M	
19	IDENTIFICATION PLATE	304 STAINLESS STEEL	304 STAINLESS STEEL	
19A	RIVET	304 STAINLESS STEEL	304 STAINLESS STEEL	
21	LANTERN RING	304 STAINLESS STEEL	304 STAINLESS STEEL	
25	DISK STACK	420(J2) STAINLESS STEEL	316L STAINLESS STEEL	Cat 3
63	SEAT GASKET	S/W GASKET, 316L SS + GRAPHITE	S/W GASKET, 316L SS + GRAPHITE	Cat 1
64	SEAL RING	PTFE + GRAPHITE	PTFE + GRAPHITE	Cat 1
65	BODY GASKET	S/W GASKET, 316L SS + GRAPHITE	S/W GASKET, 316L SS + GRAPHITE	Cat 1
67	PACKING SPACER	304 STAINLESS STEEL	304 STAINLESS STEEL	
69	PACKING RING	PTFE + Carbon Fiber	GRAPHITE	Cat 1

Note.

1. Plug/Seat hard facing (Cobalt based alloy) & Soft seat are available
2. Materials description
316 SS : ASTM A276 TP316 or JIS 316 St. Steel
410 SS : ASTM A276 TP410 or JIS 410 St. Steel
420 SS : ASTM A276 TP420 or JIS 420 St. Steel
440C SS : ASTM A276 TP440C or JIS 440C St. Steel
17-4PH : ASTM A564 630 (H1100) or JIS 630 (H1100) St. Steel
3. Above standard materials to be applicable depending on specific service conditions, other optional materials to consult Valmet.
4. Optional materials to meet to requirements of NACE MR 01-75 are available
5. The materials are subject to change as equivalent depending on detail design
6. The part no. 3, 5, 6 are delivered as a set with no. 2

Note.

1. Plug/Seat hard facing (Cobalt based alloy) & Soft seat are available
2. Materials description
316 SS : ASTM A276 TP316 or JIS 316 St. Steel
420 SS : ASTM A276 TP420 or JIS 420 St. Steel
3. Above standard materials to be applicable depending on specific service conditions, other optional materials to consult Valmet.
4. Cryogenic application : ASTM A320 B8M & 8M for studs(13) and nuts(17)
5. Optional materials to meet to requirements of NACE MR 01-75 are available
6. The materials are subject to change as equivalent depending on detail design
7. The part no. 3, 5, 6 are delivered as a set with no. 2

OMEGA design principals

- The value of pressure drop in the omega trim can be bigger than the conventional cage trims through the number of turns with multi-path and multi-stage.
- The value of pressure drop in the omega trim is a sum of the 'dynamic pressure in omega trim' and the 'dynamic pressure in valve design'.

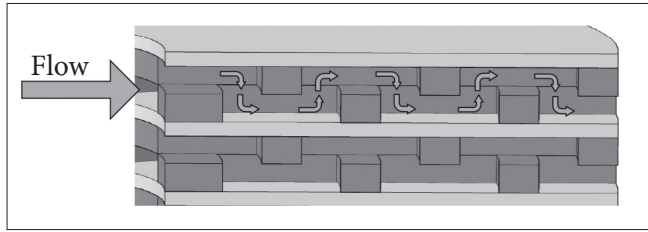

Trim outlet velocity and kinetic energy limitation

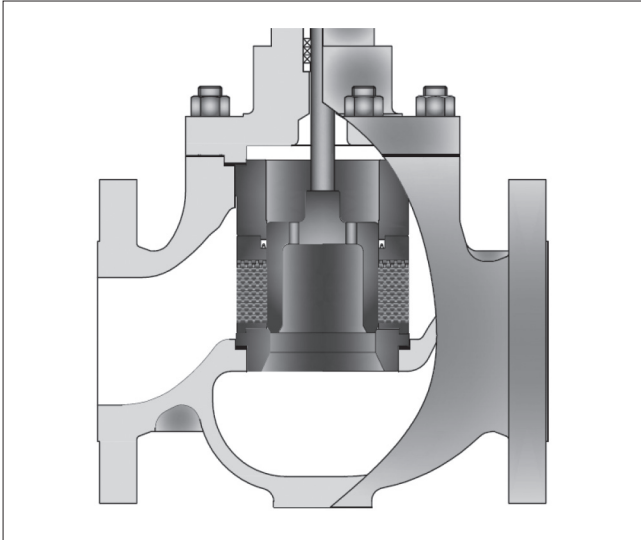

The limitation data is based on ISA04-P211.

- The exceed velocity will be made in vibration and erosive damage to the body, trim and outlet pipe wall.
- The exceed energy will be made in mechanical vibration and erosive damage to the body, trim and outlet pipe wall.

Valve trim outlet fluid kinetic energy density criteria

Service conditions	Water velocity	Oil velocity (Gf=0.8)	Air velocity (p=7 Mpa)	Kinetic energy
	m/s (ft/s)	m/s (ft/s)	m/s (ft/s)	kpa (psi)
Continuous service, single phase fluid	30 (100)	34 (112)	105 (345)	480 (70)
Cavitating and multi-phase fluids	23 (75)	26 (84)	-	275 (40)
Vibration sensitive system	12 (40)	14 (45)	42 (140)	75 (11)

Packing constructions

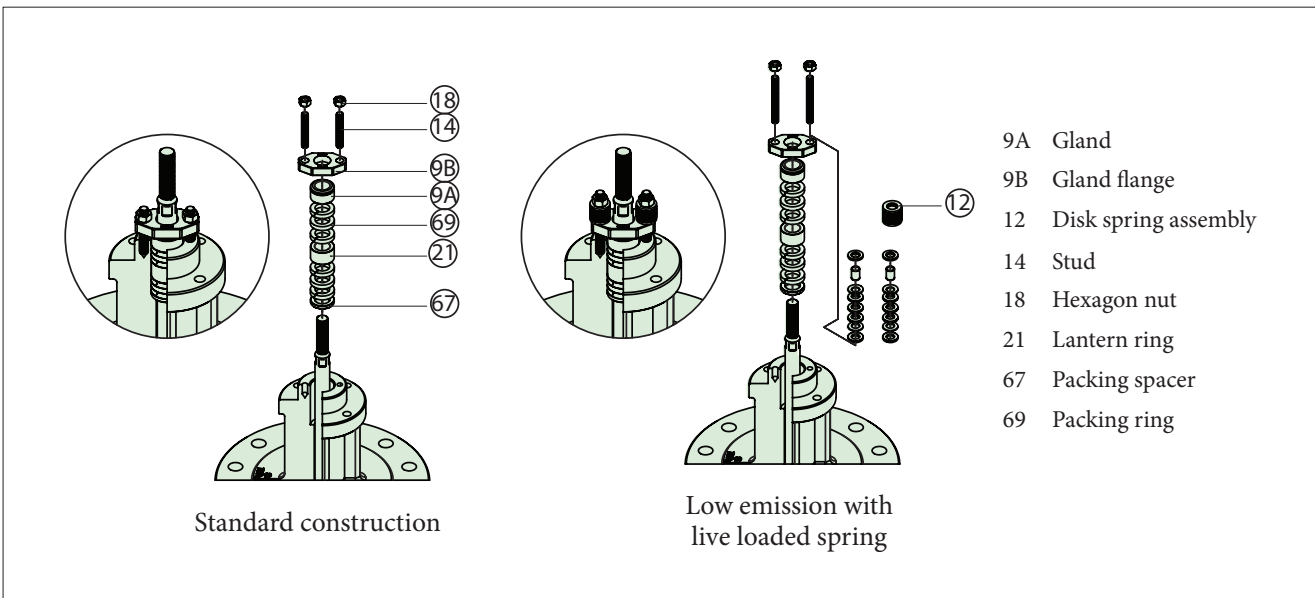

GM Series Cv vs Travel Standard OMEGA

ANSI Class: 150# ... 2500#

Size: 1" ... 16"

Flow Characteristic: LINEAR

Valve travel [%]							10	20	30	40	50	60	70	80	90	100		
F_L							1.00	1.00	1.00	1.00	1.00	1.00	1.00	1.00	1.00	1.00	1.00	1.00
Valve size		Orifice diameter			Travel		Rated Cv											
inch	mm	sign	inch	mm	inch	mm												
1	25	FC	0.6	15.7	1.2	30	0.69	1.37	2.06	2.75	3.43	4.12	4.80	5.49	6.18	7		
		1A					0.29	0.59	0.88	1.18	1.47	1.76	2.06	2.35	2.65	3		
		2A					0.16	0.31	0.47	0.63	0.78	0.94	1.10	1.25	1.41	1.6		
		3A					0.08	0.16	0.24	0.31	0.39	0.47	0.55	0.63	0.71	0.8		
1-1/2	40	FC	0.9	23.0	1.2	30	1.57	3.14	4.71	6.28	7.84	9.41	10.98	12.55	14.12	16		
		1A					0.79	1.57	2.35	3.14	3.92	4.71	5.49	6.27	7.06	8		
		2A					0.39	0.78	1.18	1.57	1.96	2.35	2.74	3.14	3.53	4		
		3A					0.20	0.39	0.59	0.78	0.98	1.18	1.37	1.57	1.76	2		
2	50	FC	1.5	37.0	1.6	40	2.55	5.10	7.65	10.20	12.75	15.29	17.84	20.39	22.94	26		
		1A					1.18	2.35	3.53	4.71	5.88	7.06	8.23	9.41	10.59	12		
		2A					0.59	1.18	1.77	2.35	2.94	3.53	4.12	4.71	5.29	6		
		3A					0.29	0.59	0.88	1.18	1.47	1.76	2.06	2.35	2.65	3		
3	80	FC	3.0	77.0	2.0	50	5.30	10.59	15.89	21.18	26.47	31.76	37.05	42.35	47.64	54		
		1A					2.75	5.49	8.24	10.98	13.73	16.47	19.21	21.96	24.70	28		
		2A					1.37	2.75	4.12	5.49	6.86	8.23	9.61	10.98	12.35	14		
		3A					0.69	1.37	2.06	2.75	3.43	4.12	4.80	5.49	6.18	7		
4	100	FC	3.6	91.0	2.0	50	8.2	16.5	24.7	32.9	41.2	49.4	57.6	65.9	74.1	84		
		1A					5.1	10.2	15.3	20.4	25.5	30.6	35.7	40.8	45.9	52		
		2A					2.6	5.1	7.6	10.2	12.7	15.3	17.8	20.4	22.9	26		
		3A					1.4	2.7	4.1	5.5	6.9	8.2	9.6	11.0	12.4	14		
6	150	FC	4.1	133.6	2.4	60	14.3	28.6	43.0	57.3	71.6	85.9	100.2	114.5	128.8	146		
		1A					8.8	17.7	26.5	35.3	44.1	52.9	61.8	70.6	79.4	90		
		2A					4.4	8.8	13.2	17.6	22.1	26.5	30.9	35.3	39.7	45		
		3A					2.2	4.3	6.5	8.6	10.8	12.9	15.1	17.3	19.4	22		
8	200	FC	6.9	175.5	3.1	70	24.7	49.4	74.1	98.8	123.5	148.2	172.9	197.6	222.3	252		
		1A					15.3	30.6	45.9	61.2	76.5	91.8	107.0	122.3	137.6	156		
		2A					7.7	15.3	22.9	30.6	38.2	45.9	53.5	61.2	68.8	78		
		3A					3.9	7.8	11.8	15.7	19.6	23.5	27.4	31.4	35.3	40		
10	250	FC	8.1	214.2	3.5	80	37.7	75.3	113.0	150.6	188.2	225.9	263.5	301.1	338.8	384		
		1A					23.0	45.9	68.8	91.8	114.7	137.6	160.6	183.5	206.4	234		
		2A					11.4	22.8	34.1	45.5	56.9	68.2	79.6	91.0	102.3	116		
		3A					5.7	11.4	17.1	22.7	28.4	34.1	39.8	45.5	51.2	58		
12	300	FC	10.4	264.8	4.7	120	55.0	109.9	164.8	219.6	274.5	329.4	384.3	439.2	494.0	560		
		1A					33.4	66.7	100.0	133.3	166.7	200.0	233.3	266.6	299.9	340		
		2A					16.7	33.4	50.0	66.7	83.3	100.0	116.7	133.3	150.0	170		
		3A					8.2	16.5	24.7	32.9	41.2	49.4	57.6	65.9	74.1	84		
14	350	FC	12.4	315.5	5.5	140	75.6	151.1	226.5	302.0	377.5	452.9	528.4	603.8	679.3	770		
		1A					46.1	92.2	138.3	184.3	230.4	276.5	322.5	368.6	414.6	470		
		2A					23.0	45.9	68.8	91.8	114.7	137.6	160.6	183.5	206.4	234		
		3A					11.4	22.8	34.1	45.5	56.9	68.2	79.6	91.0	102.3	116		
16	400	FC	14.1	357.7	6.3	160	100.0	200.1	300.1	400.0	500.0	600.0	699.9	799.9	899.8	1020		
		1A					61.2	122.4	183.6	244.7	305.9	367.0	428.2	489.3	550.5	624		
		2A					30.4	60.8	91.2	121.6	152.0	182.3	212.7	243.1	273.5	310		
		3A					15.1	30.2	45.3	60.4	75.5	90.6	105.7	120.8	135.9	154		

NOTE

C_v: Valve flow coefficientF_L: Liquid pressure recovery factor

FC: Full capacity

1A: 1-Step reduction

2A: 2-Step reduction

3A: 3-Step reduction

GM, Valve dimensions and weights

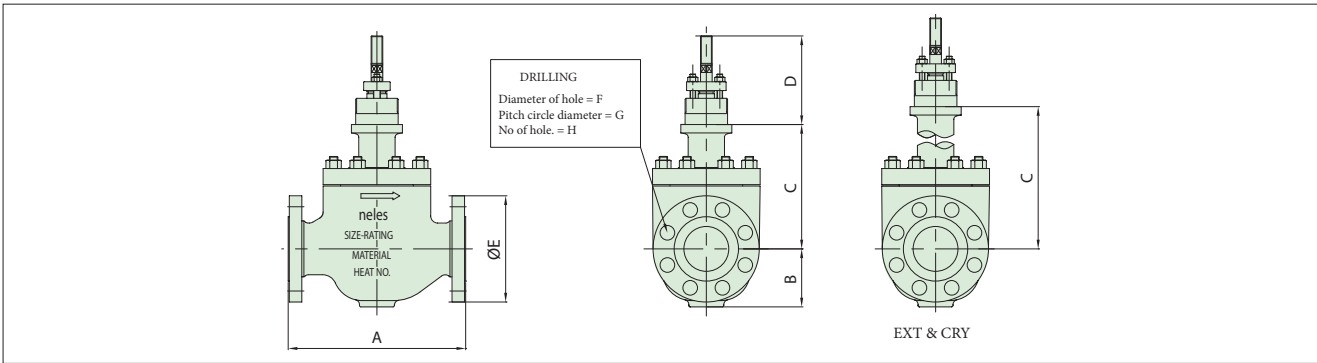

150 #/ 300 #/ 600

Dimension (mm)	A			B			C			D	E			F			G			H			Weight (kg) (Approximate)		
	150#	300#	600#	150#	300#	600#	STD	EXT	CRY	COMMON	150#	300#	600#	150#	300#	600#	150#	300#	600#	150#	300#	600#	150#	300#	600#
25	184	197	210	55	63	63	142	250	400	110	110	125	125	15.9	19.1	19.1	79.4	88.9	88.9	4	4	4	14	15	23
40	222	235	251	65	78	78	161	269	419	110	125	155	155	15.9	22.2	22.2	98.4	114.3	114.3	4	4	4	22	23	27
50	254	267	286	83	83	83	178	333	458	110	150	165	165	19.1	19.1	19.1	120.7	127	127	4	8	8	30	32	40
80	298	318	337	109	109	120	222	395	545	115	190	210	210	19.1	22.2	22.2	152.4	168.3	168.3	4	8	8	65	67	72
100	352	368	394	135	135	135	248	402	552	140	230	255	275	19.1	22.2	25.4	190.5	200	215.9	8	8	8	100	103	112
150	451	473	508	170	170	178	340	467	642	150	280	320	355	22.2	22.2	28.6	241.3	269.9	292.1	8	12	12	185	195	240
200	543	568	610	230	230	230	451	557	732	150	345	380	420	22.2	25.4	31.8	298.5	330.2	349.2	8	12	12	363	385	443
250	673	708	752	275	275	275	488	670	870	150	405	445	510	25.4	28.6	34.9	362	387.4	431.8	12	16	16	552	595	681
300	737	775	819	350	350	350	543	716	916	140	485	520	560	25.4	31.8	34.9	431.8	450.8	489	12	16	20	905	955	1020
350	889	927	972	385	385	385	616	846	1046	210	535	585	605	28.6	31.8	38.1	476.3	514.4	527	12	20	20	1170	1230	1311
400	1016	1057	1108	440	440	440	692	909	1109	220	595	650	685	28.6	34.9	41.3	539.8	571.5	603.2	16	20	20	1380	1460	1587

Dimension (inch)	A			B			C			D	E			F			G			H			Weight (lbs) (Approximate)		
	150#	300#	600#	150#	300#	600#	STD	EXT	CRY	COMMON	150#	300#	600#	150#	300#	600#	150#	300#	600#	150#	300#	600#	150#	300#	600#
1"	7.2	7.8	8.3	2.2	2.5	2.5	5.6	9.8	15.7	4.3	4.3	4.9	4.9	0.6	0.8	0.8	3.1	3.5	3.5	4	4	4	31	33	51
1-1/2"	8.7	9.3	9.9	2.6	3.1	3.1	6.3	10.6	16.5	4.3	4.9	6.1	6.1	0.6	0.9	0.9	3.9	4.5	4.5	4	4	4	49	51	60
2"	10	10.5	11.3	3.3	3.3	3.3	7	13.1	18	4.3	5.9	6.5	6.5	0.8	0.8	0.8	4.8	5	5	4	8	8	66	71	88
3"	11.7	12.5	13.3	4.3	4.3	4.7	8.7	15.6	21.5	4.5	7.5	8.3	8.3	0.8	0.9	0.9	6	6.6	6.6	4	8	8	143	148	159
4"	13.9	14.5	15.5	5.3	5.3	5.3	9.8	15.8	21.7	5.5	9.1	10	10.8	0.8	0.9	1	7.5	7.9	8.5	8	8	8	221	227	247
6"	17.8	18.6	20	6.7	6.7	7	13.4	18.4	25.7	5.9	11	12.6	14	0.9	0.9	1.1	9.5	10.6	11.5	8	12	12	408	430	529
8"	21.4	22.4	24	9.1	9.1	9.1	17.8	21.9	28.8	5.9	13.6	15	16.5	0.9	1	1.3	11.8	13	13.7	8	12	12	800	849	977
10"	26.5	27.9	29.6	10.8	10.8	10.8	19.2	26.4	34.3	5.9	15.9	17.5	20.1	1	1.1	1.4	14.3	15.3	17	12	16	16	1217	1312	1501
12"	29	30.5	32.2	13.8	13.8	13.8	21.4	28.2	36.1	5.9	19.1	20.5	22	1	1.3	1.4	17	17.7	19.3	12	16	20	1995	2105	2249
14"	35	36.5	38.3	15.2	15.2	15.2	24.3	33.3	41.2	8.3	21.1	23	23.8	1.1	1.3	1.5	18.8	20.3	20.7	12	20	20	2579	2712	2890
16"	40	41.6	43.6	17.3	17.3	17.3	27.2	35.8	43.7	8.7	23.4	25.6	27	1.1	1.4	1.6	21.3	22.5	23.7	16	20	20	3042	3219	3499

900 #/ 1500

Dimension (mm)	A		B		C		D	E		F		G		H		Weight (kg)	
	900#	1500#	900#	1500#	STD	EXT	COMMON	900#	1500#	900#	1500#	900#	1500#	900#	1500#	900#	1500#
25	292	292	78	78	236	330	110	150	180	25.4	25.4	101.6	101.6	4	4	60	60
40	333	333	100	100	240	380	110	180	180	28.6	28.6	123.8	123.8	4	4	63	63
50	375	375	113	113	240	380	110	215	215	25.4	25.4	165.1	165.1	8	8	67	67
80	441	460	142	142	322	430	115	240	265	25.4	31.8	190.5	203.2	8	8	150	163
100	511	530	182	182	375	475	140	290	310	31.8	34.9	235	241.3	8	8	244	255
150	714	768	210	240	420	500	150	380	395	31.8	39	317.5	317.5	12	12	530	540
200	914	972	290	290	550	600	150	470	485	38.1	45	393.7	393.7	12	12	698	821
250	991	1067	310	350	600	700	150	545	585	38.1	51	469.9	482.6	16	12	955	1137
300	1130	1219	385	385	680	800	140	610	675	38.1	54	533.4	571.5	20	16	1180	1240
350	1257	1257	385	385	770	920	210	640	750	41.3	61	558.8	635	20	16	1387	1477
400	1422	1422	450	450	850	1050	220	705	825	44.5	67	616	704.8	20	16	1601	1721

Dimension (inch)	A		B		C		D	E		F		G		H		Weight (lbs)	
	900#	1500#	900#	1500#	STD	EXT	COMMON	900#	1500#	900#	1500#	900#	1500#	900#	1500#	900#	1500#
1"	11.5	11.5	3	3	9	13	4	5.9	7.1	1	1	4	4	4	4	132	132
1-1/2"	13.1	13.1	3.9	3.9	9.5	15	4	7.1	7.1	1.1	1.1	4.9	4.9	4	4	139	139
2"	14.8	14.8	4.4	4.4	9.5	15	4	8.5	8.5	1	1	6.5	6.5	8	8	148	148
3"	17.4	18.1	5.6	5.6	12.7	17	5	9.4	10.4	1	1.3	7.5	8	8	8	331	359
4"	20.1	20.9	7.2	7.2	15	19	6	11.4	12.2	1.3	1.4	9.3	9.5	8	8	538	562
6"	28.1	30.2	8.3	9.4	17	20	6	15	15.6	1.3	1.5	12.5	12.5	12	12	1168	1191
8"	36	38.3	11.4	11.4	22	24	6	18.5	19.1	1.5	1.8	15.5	15.5	12	12	1539	1810
10"	39	42	12.2	13.8	24	28	6	21.5	23	1.5	2	18.5	19	16	12	2105	2507
12"	44.5	48	15.2	15.2	27	31	6	24	26.6	1.5	2.1	21	22.5	20	16	2602	2734
14"	49.5	49.5	15.2	15.2	30	36	8	25.2	29.5	1.6	2.4	22	25	20	16	3058	3256
16"	56	56	17.7	17.7	33	41	8	27.8	32.5	1.8	2.6	24.3	27.7	20	16	3530	3794

Bigger sizes and ASME class 2500 ratings are available, please contact Valmet.

How to order

Globe Omega trim, multi-stage type, series GM

1.	2.	3.	4.	5.	6.	7.	8.	9.	10.	11.	12.	13.	14.	15.	16.	17.	18.	19.	20.	21.	22.
GM	02	H	Z	B	J2	B	P2	X	BC	S1	P2	X	S	G	G	S	G	X	A	E	FG

Valve constructions

1.	Valve series		
GM	Globe Omega trim, multi-stage type		

2.	Body size		
01	1" / DN 25	1H	1.5" / DN 40
02	2" / DN 50	03	3" / DN 80
04	4" / DN 100	06	6" / DN 150
08	8" / DN 200	10	10" / DN 250
12	12" / DN 300	14	14" / DN 350
16	16" / DN 400	18	18" / DN 450
20	20" / DN 500	24	24" / DN 600
28	28" / DN 700	30	30" / DN 750
32	32" / DN 800	36	36" / DN 900
YY	Special		

3.	Pressure rating		
C	ASME class 150	D	ASME class 300
F	ASME class 600	G	ASME class 900
H	ASME class 1500	I	ASME Class 2500
J	EN PN 10	K	EN PN 16
L	EN PN 25	M	EN PN 40
N	EN PN 63	P	EN PN 100
B	EN PN 160	E	EN PN 250
Y	Special	R	JIS 10K
T	JIS 20K		

4.	End connection		
W	Flanged RF, ASME B16.5		
C	Flanged RF, EN 1092-1		
Z	Ring joint flange, ASME B16.5		
V	Socket welding, ASME B16.11		
Q	Butt welding, ASME B16.25		
Y	Special		

5.	Bonnet construction	
	Bonnet Type	Actuator Connection
A	General	Applicable for VD_25/29/37
B	General	Applicable for VD_48/55
C	General	Applicable for VC_30, VB_32
D	General	Applicable for VC/VB_40/50
T	General	Applicable for VC/VB_60/70
E	Extension	Applicable for VD_25/29/37
F	Extension	Applicable for VD_48/55
G	Extension	Applicable for VC_30, VB_32
H	Extension	Applicable for VC/VB_40/50
U	Extension	Applicable for VC/VB_60/70
P	Cryogenic	Applicable for VD_25/29/37
Q	Cryogenic	Applicable for VD_48/55
R	Cryogenic	Applicable for VC_30, VB_32
S	Cryogenic	Applicable for VC/VB_40/50
V	Cryogenic	Applicable for VC/VB_60/70
Y	Special	Special

6.	Body material		
J2	A216 gr. WCB		
S6	A351 gr. CF8M		
S1	A351 gr. CF3M		
J4	A217 gr. WC6		
CG	A217 gr. WC9		
YY	Special		

- Bonnet material is equivalent to body material.

7.	Model code		
B	Model B		

Trim constructions

8.	Plug material	
	Material	Description
P2	CA40	General for carbon steel valve
T6	CF8M + HCr	General for stainless steel valve
YY	Special	Special materials

9.	Plug application		
X	Not applicable		
A	Cobalt based alloy		
Y	Special		

10.	Stem material	
	Material	Description
BC	630 SS + HCr	General for carbon steel valve
TC	316 SS + HCr	General for stainless steel valve
VX	XM-19	

11.	Seat type		
S1	Single metal seat		
YY	Special		

12.	Seat / disk stack material		
	Seat	Disk Stack	Cage Guide
P2	CA40	SUS 420J2	CA40
R4	CF8M	316L SS	CF8M + HCr
YY	Special	Special	Special

13.	Seat application		
X	Not applicable		
A	Cobalt based alloy		
Y	Special		

