

# Neles™ R-series V-port segment valve for MC-applications

In many pulp applications, 8-19 % medium consistency is used to achieve cost savings or technical benefits in the process. The medium consistency pump, is basically a centrifugal pump with an open impeller. It acts as a turbulence generator fluidizing the pulp at the inlet. A normal head is up to 150 meters and pulp flow is controlled by means of a valve mounted directly on the pump discharge flange.

There are two basic ways to run the pumps, as variable speed pumps or static head pumps. There is clear difference in how to use the medium consistency valves with these two pump styles.

With a variable speed pump, it is important to run the pump with a fully 90 degree open valve. The valve will be throttled only when the pressure differential over the valve goes below the critical point that creates the danger of blocking the valve. This can happen only at very low pump speeds. The other case is the conventional method, whereby the static head of the pump is controlled by means of a medium consistency valve. In these cases the valve opening is typically limited to 70 degrees, to ensure that the pressure differential over the valve stays above critical level.

Valmet has created a specially designed V-port segment valve for this highly visible application. An extensive amount of testing has been conducted in cooperation with a leading pump manufacturer and a university. This research work has given us important knowledge of the flow behavior and clogging prevention in this demanding application.

This specially designed V-port segment valve provides an optimized flow path for medium consistency pulp. The flow path in the valve is continuously increased to eliminate restrictions where material may build up. The outlet flange is one size bigger than the inlet to ensure this. Additionally, the body is equipped with a flushing connection. The flow path is V-contoured to be able to control small capacities without risk of dewatering.

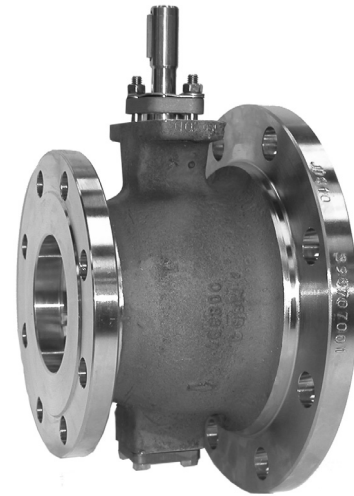

## Features

### Integral body construction

- R-Series valves feature one piece body construction with no flange rings, inserts, or end caps that create potential leak paths.

### Rugged, self-adjusting metal seat

- The size and durability of the R-Series V-port segment valve seat is in a class by itself. Carefully engineered seat design assures that flow does not directly impinge on the seating surface, thereby extending seat sealing life. Energized pressure seal design ensures correct contact between the seat and segment at all times. Seating capabilities are totally unaffected by pipeline forces, which assures more reliable valve operation.

### Protected bearings

- Both trunnion bearings are located inside the valve body. Having the lower shaft bearing inside the body provides a larger bearing area, lower bearing loads, and longer bearing life. Locating the bearing outside of the flow stream further enhances performance.

### Economical

- Low seat torque requirements combined with compact actuator designs result in a lower cost total package.

### Valves for dioxide bleaching stages

- Material selection must be considered when bleaching agent is chlorine dioxide. A full titanium segment valve is available and also a superaustenitic stainless steel 254SMo version if the chlorine concentration is not very high.

## Exploded view, sizes DN80 - 300/3" - 12"

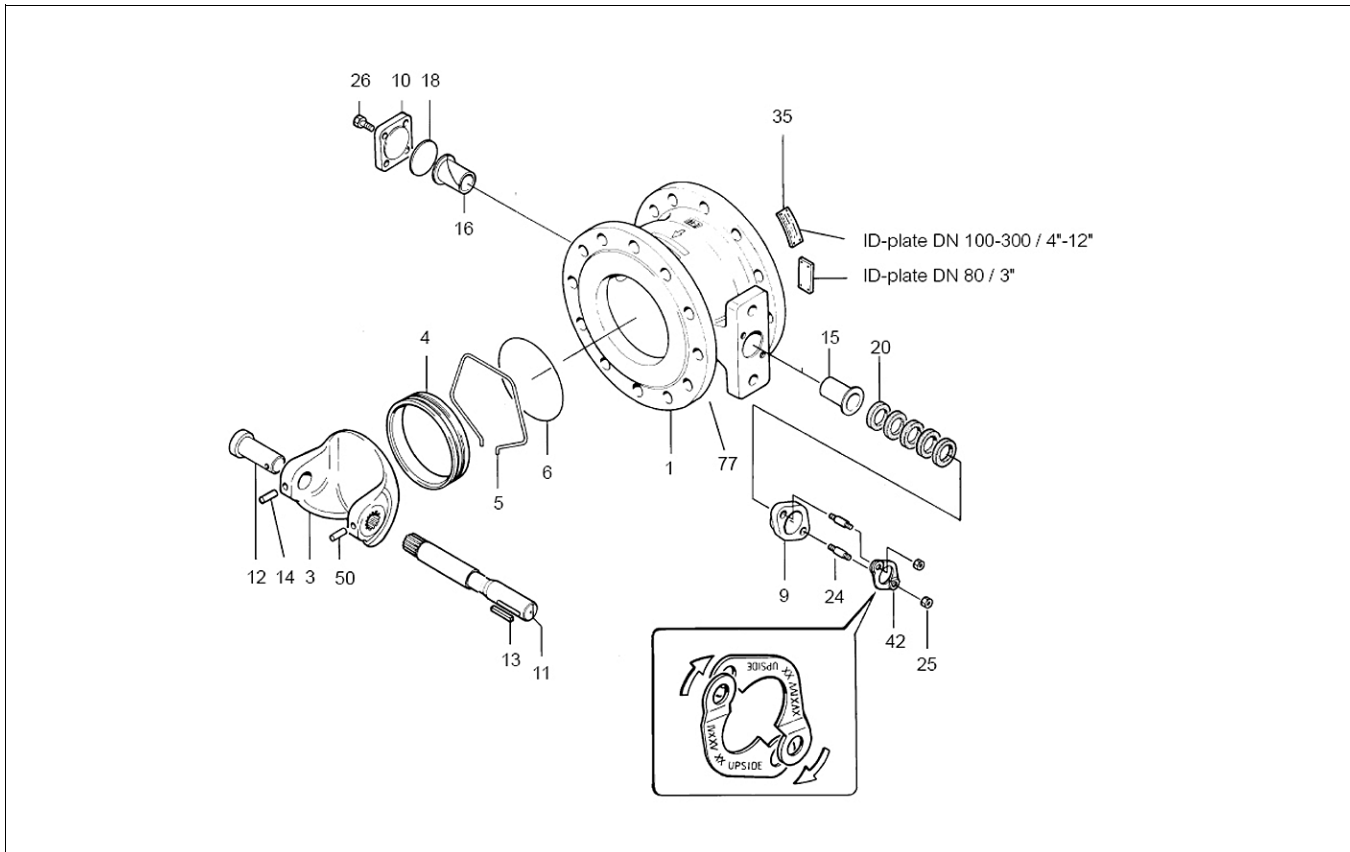

### Parts list

Part	Name	Materials		
		Stainless steel	Titanium	254SMo
1	Body	ASTM A351 gr. CG8M	ASTM B 367	ASTM A 351gr. CK3MCuN
3	V-port segment	SIS 2324 + chromium / AISI 329	ASTM B 367 + Ti02	ASTM A 351gr. CK3MCuN+Ti02
4	Seat	Cobalt based alloy	ASTM B348	ASTM B 348 gr. 5
5	Lock spring	INCONEL 625	ASTM B348	ASTM B 348 gr. 5
6	Back seal	SS + PTFE	TITANIUM + PTFE	TITANIUM + PTFE
9	Gland follower	ASTM A351 gr. CF8M	ASTM B348	UNSS 31254
10	Blind flange	ASTM A351 gr. CG8M	ASTM B348	UNSS 31254
11	Drive shaft	SIS 2324 / AISI 329	ASTM B348	UNSS 31254
12	Shaft	SIS 2324 / AISI 329	ASTM B348	UNSS 31254
13	Key	SIS 2324 / AISI 329	SIS 2324 / AISI 329	SS 142324
14	Cylindrical pin	SIS 2324 / AISI 329	ASTM B348	UNSN 10276
15	Bearing	PTFE + SS net	PVDF	PVDF
16	Bearing	PTFE + SS net	PVDF	PVDF
18	Sealing plate	Graphite	PTFE	PTFE
20	Packing	PTFE	PTFE	PTFE
24	Stud	ISO 3506 A4-80	ASTM B348	ISO 3506 A4-80
25	Hexagon nut	ISO 3506 A4-80	ASTM B348	ISO 3506 A4-70/80
26	Hexagon bolt	ISO 3506 A4-80	ASTM B348	ISO 3506 A4-80
35	Identification plate	AISI 304	AISI 304	AISI 304
42	Retainer plate	AISI 316L	Hastelloy C-276	ASME 316L/1.4435
50	Taper pin	SIS 2324 / AISI 329	ASTM B329	UNSN 10276
77	Hexagon plug	AISI 317	ASTM B348	AISI 317

## Exploded view, sizes DN350 - 500/14" - 20"

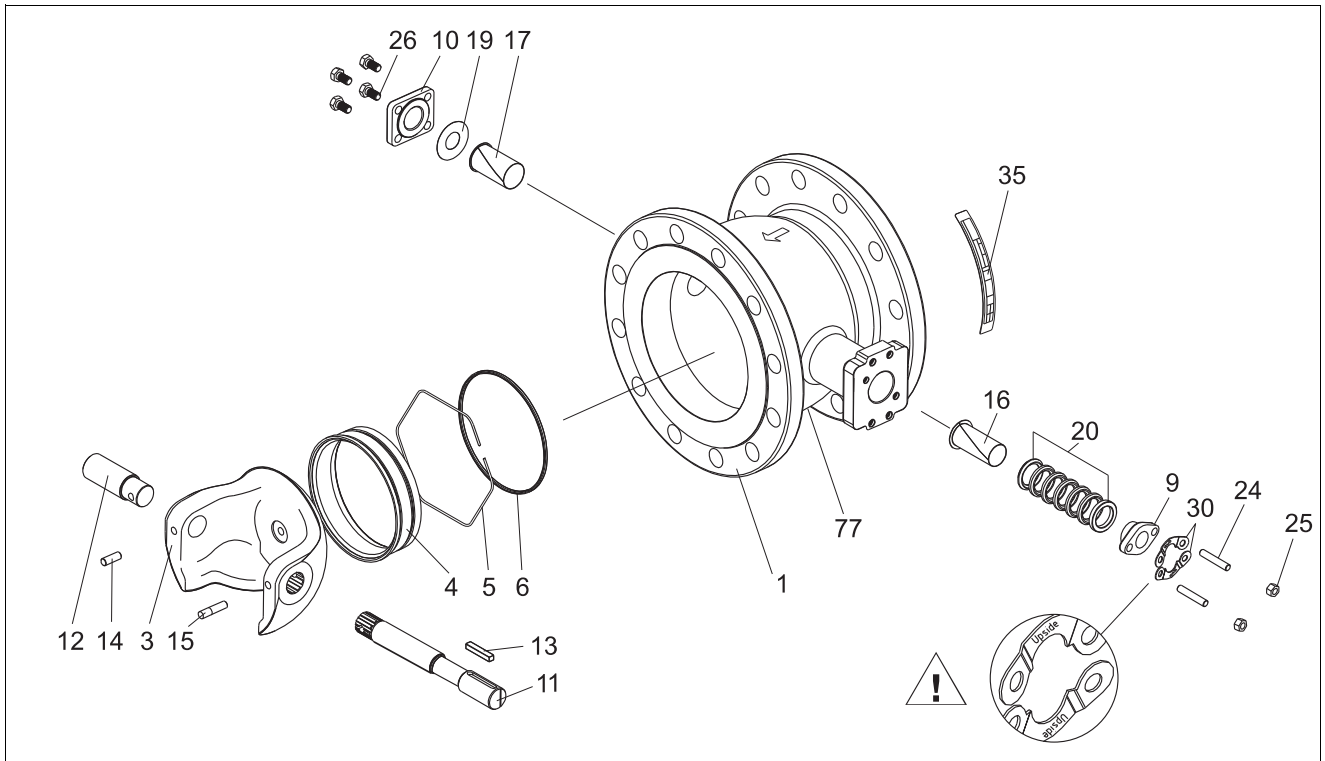

### Parts list

Part	Name	Body material
		Stainless steel
1	Body	ASTM A351 gr. CG8M
3	V-port segment	SIS 2324 + chromium
4	Seat	Cobalt based alloy
5	Lock spring	INCONEL 625
6	Back seal	SS Eligiloy spring + PTFE
9	Gland follower	ASTM A351 gr. CF8M
10	Blind flange	ASTM A351 gr. CG8M
11	Drive shaft	SIS 2324/AISI 329 duplex SS
12	Shaft	SIS 2324/AISI 329 duplex SS
13	Key	SIS 2324/AISI 329
14	Cylindrical pin	SIS 2324/AISI 329
15	Cylindrical pin	SIS 2324/AISI 329
16	Bearing	PTFE + SS net
17	Bearing	PTFE + SS net
19	Sealing plate	Graphite
20	Packing	PTFE
24	Stud	ISO 3506 A4-80/B8M
25	Hexagon nut	ISO 3506 A4-80/B8M
26	Hexagon bolt	ISO 3506 A4-80/B8M
30	Retainer plate	AISI 316L
35	Identification plate	AISI 304
77	Hexagon plug	AISI 317L

## Technical specifications

### Type

Reduced-bore quarter-turn valve

### Pressure ratings

Body

Sizes DN 50 - 300 / 2" - 12". PN 25; ANSI 150

Sizes DN 350 - 500 / 14" - 20" PN 10-40, ASME 150-300

DIN PN 25; ANSI 150

Trim

DIN PN 25; ANSI 150

(Note the pressure/temperature curve)

### Sizes

DN 50, 80, 100, 150, 200, 250, 300, 350, 400, 500

Inch 2", 3", 4", 6", 8", 10", 12", 14", 16", 20"

### Face-to-face dimensions

Special

### Temperature range

-40°C ... +260 °C / -40...+500 °F.

### Inherent flow characteristic

Equal percentage.

### Tightness

Tightness is tested in the direction by the arrow, see page 4, according to ISO 5208. The standard tightness of a metal-seated segment valve is 10 x ISO 5208 Rate D. This tightness corresponds to 1/100 of max seat leakage allowed by ANSI/FCI 70.2 Class IV.

### Valve pressure and leak test

All valves manufactured by Valmet undergo pressure testing. The test pressure of an R-series valve body is 1.5 x the pressure rating and the test pressure of a seat is 1.1 x the maximum permissible shut-off pressure. The test medium is water containing a corrosion inhibitor.

Maximum allowable leakage		
Size DN / inch	Metal seat	Soft seat
50 / 2	3.00 ml/min	0.30 ml/min
80 / 3	4.80 ml/min	0.48 ml/min
100 / 4	6.00 ml/min	0.60 ml/min
150 / 6	9.00 ml/min	0.90 ml/min
200 / 8	12.00 ml/min	1.20 ml/min
250 / 10	15.00 ml/min	1.50 ml/min
300 / 12	18.00 ml/min	1.80 ml/min
350 / 14	21.00 ml/min	2.10 ml/min
400 / 16	24.00 ml/min	2.40 ml/min
500 / 20	30.00 ml/min	-

### Valve body ratings

These are maximum working pressure ratings of the valve body only in accordance with ASME B16.34. The maximum allowed throttling differential pressure chart below, determines the differential pressure limitations according to specific service conditions.

Temperature	Maximum valve body rating — bar / psi	
	DIN PN 25	ASME Class 150
	Stainless Steel	Titanium
-30 to 27 °C / -20 to 100 °F	19.0 / 275	36.5 / 530
93 °C / 200 °F	16.6 / 240	30 / 435*
149 °C / 300 °F	14.8 / 215	—
204 °C / 400 °F	13.4 / 195	—
250 °C / 482 °F	12.0 / 174	—

\* Rating at 100°C / 212°F

### Maximum throttling differential pressure for steel valves

Note! Noise and cavitation should also be taken into account when determining the maximum pressure differential of a valve.

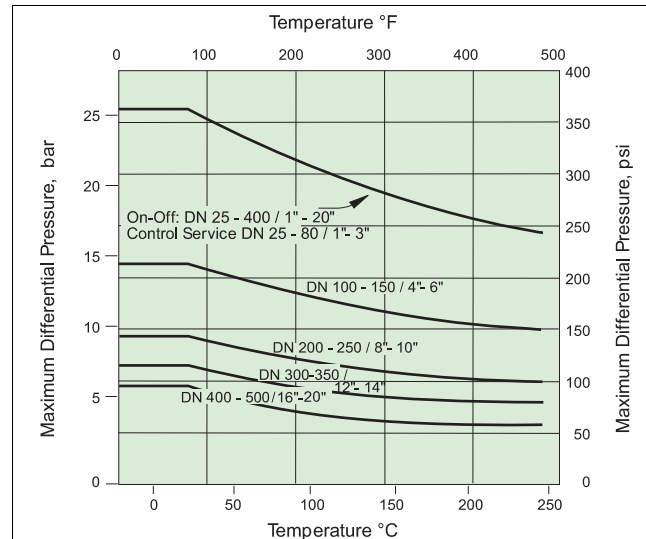

### Max. differential pressure ratings of titanium standard valves

Note! The maximum shut-off pressure differential of titanium segment valves is 19 bar / 275 psi.

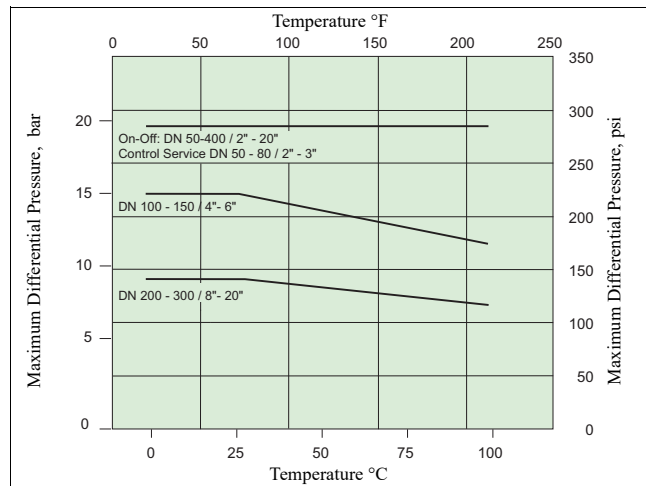

## Maximum $C_v$ and resistance coefficients for R2\_S series valves

Valve size DN	Valve size inch	Metal-seated valve			
		R2-S-valve			
		$C_v$ 100% 1)	$\xi$ 100 %	$C_v$ 70°	$\xi$ 70°
50	2	163	0.41	54	5.2
80	3	420	0.50	125	5.6
100	4	620	0.56	200	5.1
150	6	1260	0.68	370	7.8
200	8	2030	0.83	610	9.1
250	10	3210	0.81	970	9.0
300	12	4490	0.86	1380	9.0
350	14	6440	0.77	1775	10.2
400	16	8510	0.76	2375	9.7

1)  $C_v$  100 % corresponds to a 95° turning angle.

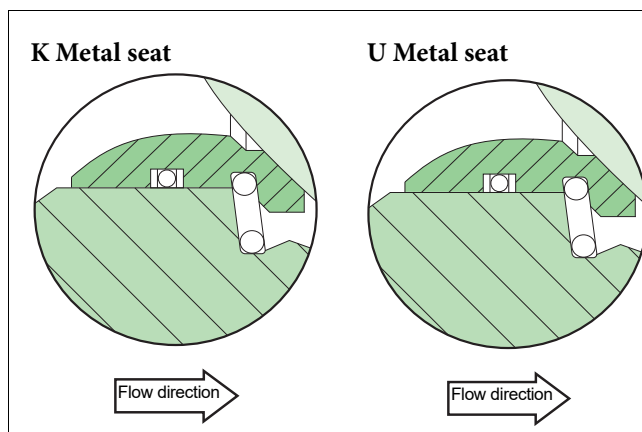

### Seats designs

#### K Metal seat

Seat:	316 SS + Cobalt based hard facing
Spring:	Inconel 625
Seat seal:	Filled PTFE lipseal / Elgiloy spring
Temp. range:	-40 °C... +260 °C / - 40 °F ...+500 °F
Service:	General service

#### U Metal seat

Seat:	Titanium
Spring:	Titanium
Seat seal:	Virgin PTFE lipseal / Titanium spring
Temp. range:	-40 °C... +120 °C / - 40 °F ...+250 °F
Service:	Specially for chloride applications except dry chlorine gas.

### ACTUATOR MOUNTING POSITIONS

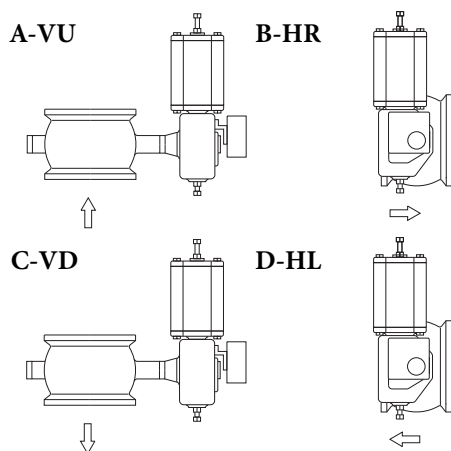

#### Note!

- The most common positions are shown here. Should you wish to use some other mounting position, please consult with your local automation expert at Valmet.
- The mounting position can be changed at the site without extra accessories. See bulletin 3 R 71 for mounting, operation and maintenance.
- If no mounting position is given, the actuator is mounted at the factory in position A-VU.
- Following mounting positions are not possible  
 A-VU, A-HU, A-HR, A-HL, A-VD, A-HD  
 for following valve units:  
 R2DS04/06-B1J10  
 R2DS10/12-B1J20  
 R2DS12/14-B1J25

**DIMENSIONS, R2\_S**

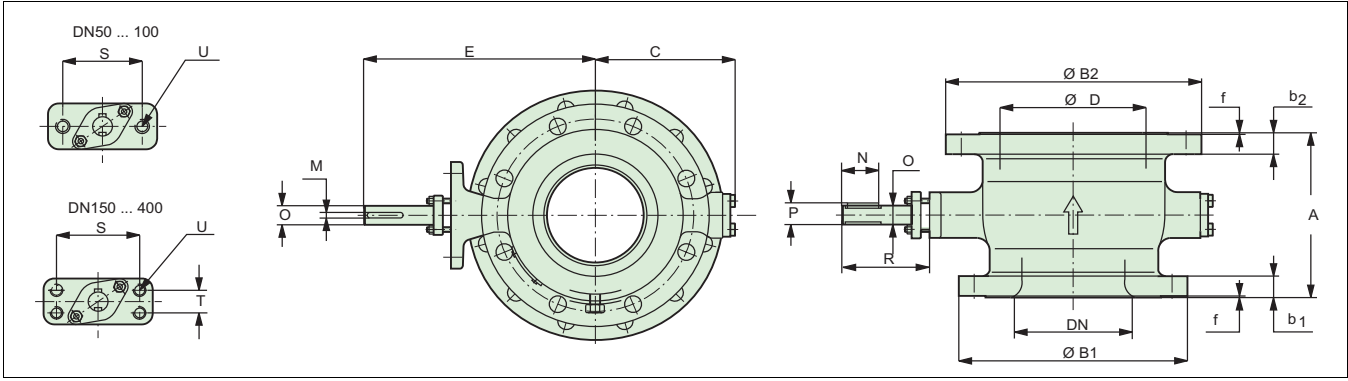

Size	Main dimensions, mm															
	DN	D	A	C	E	E'	S	T	O	R	R'	M	P	N	U UNC	Plug NPTF
50/80	50	80	165	92	170	205	70	-	15	70	105	4.8	17	25	3/8	1/2
80/100	80	102	165	108	196	241	90	-	20	79	124	4.8	22.2	35	1/2	1/2
100/150	100	136	163	117	205	250	90	-	20	80	125	4.8	22.2	35	1/2	1/2
150/200	150	190	207	177	295	325	110	32	25	110	140	6.4	27.8	46	1/2	1/2
200/250	200	240	248	200	346	362	130	32	25	140	156	6.4	27.8	46	1/2	3/4
250/300	250	296	297	250	390	420	130	32	35	141	171	9.5	39.1	58	1/2	3/4
300/350	300	336	338	270	462	497	160	40	40	165	200	9.5	44.2	68	5/8	3/4
350/400	350	390	400	311	513	513	160	40	45	200	200	12.7	50.4	80	M16	3/4
400/450	400	450	400	353	584	584	160	55	50	230	230	12.7	55.5	90	M20	3/4
500/600	500	660	508	420	727	727	230	90	70	292	292	19.05	78.2	119	M24	3/4

Size	Flange dimension S, mm																							
	R2JS PN 10						R2KS PN 16						R2LS PN 25						R2MS PN 40					
	B1	b1	B2	b2	F	kg	B1	b1	B2	b2	F	kg	B1	b1	B2	b2	F	kg	B1	b1	B2	b2	F	kg
50/80	165	20	200	20	2	12	165	20	200	20	2	12	165	20	200	20	3	12	-	-	-	-	-	-
80/100	200	20	220	20	2	16	200	20	220	20	2	16	200	24	235	24	2	18	-	-	-	-	-	-
100/150	220	20	285	22	2	24	220	20	285	22	2	24	235	24	300	28	2	30	-	-	-	-	-	-
150/200	285	22	340	24	2	43	285	22	340	24	2	43	300	28	360	30	2	52	-	-	-	-	-	-
200/250	340	24	395	26	2	68	340	24	405	26	2	69	360	30	425	32	2	80	-	-	-	-	-	-
250/300	395	26	445	26	2	98	405	26	460	28	2	100	425	32	485	34	2	110	-	-	-	-	-	-
300/350	445	26	505	26	2	145	460	28	520	30	2	155	485	34	555	38	2	175	-	-	-	-	-	-
350/400	505	26	565	26	2	162	520	30	580	32	2	172	555	38	620	40	2	201	580	46	660	50	2	244
400/450	565	26	615	28	2	196	580	32	640	40	2	219	620	40	670	46	2	249	660	50	685	57	2	298
500/600	670	26	780	28	2	289	715	42	840	40	2	325	730	46	845	46	2	361	755	57	890	60	2	398

Size	FLANGE DIMENSIONS, mm													
	R2CS ANSI 150							R2DS ANSI 300						
B1	b1	B2	b2	F	kg	B1	b1	B2	b2	F	kg			
50/80	150	26.3	190	19.5	2	13	165	22.7	210	29	2	19		
80/100	191	19.5	229	24.0	2	17	210	24	254	24	2	19		
100/150	229	24.0	279	25.5	2	27	254	24	318	28	2	30		
150/200	279	25.5	343	29.0	2	46	318	28	381	34	2	50		
200/250	343	26.0	406	30.5	2	74	381	34	450	38	2	82		
250/300	406	30.6	483	32.0	2	105	450	38	521	42	2	115		
300/350	483	32.0	534	35.0	2	170	521	42	584	42	2	190		
350/400	535	35.4	595	37	2	187	585	54.4	650	57.6	2	247		
400/450	595	37	635	40.1	2	225	650	57.6	710	60.8	2	308		
500/600	700	41.3	815	46.1	2	338	775	64	915	68.3	2	408		

Size	Flange dimensions, mm																	
	R2RS JIS 10 K						R2SS JIS 16 K						R2TS JIS 20 K					
	B1	b1	B2	b2	f	kg	B1	b1	B2	b2	f	kg	B1	b1	B2	b2	f	kg
50/80	155	16	185	18	2	9	155	16	200	20	2	11	155	18	200	22	2	13
80/100	185	18	210	18	2	14	200	20	225	22	2	17	200	22	225	24	2	20
100/150	210	18	280	22	2	23	225	22	305	24	2	28	225	24	305	28	2	34
150/200	280	22	330	22	2	41	305	24	350	26	2	49	305	28	350	30	2	59
200/250	330	22	400	24	2	65	350	26	430	28	2	78	350	30	430	34	2	94
250/300	400	24	445	24	2	98	430	28	480	30	2	118	430	34	480	36	2	142
300/350	445	24	490	26	3	165	480	30	540	34	3	150	480	36	540	40	3	180
350/400	490	26	560	28	3	159	540	34	605	38	3	192	540	40	605	46	3	201
400/450	560	28	620	30	3	201	605	38	675	40	3	247	605	46	675	48	3	260
500/600	675	30	795	32	3	298	730	42	845	46	3	360	730	50	845	54	3	378

R', E: Dimension with live loading construction

R2\_S-B1C

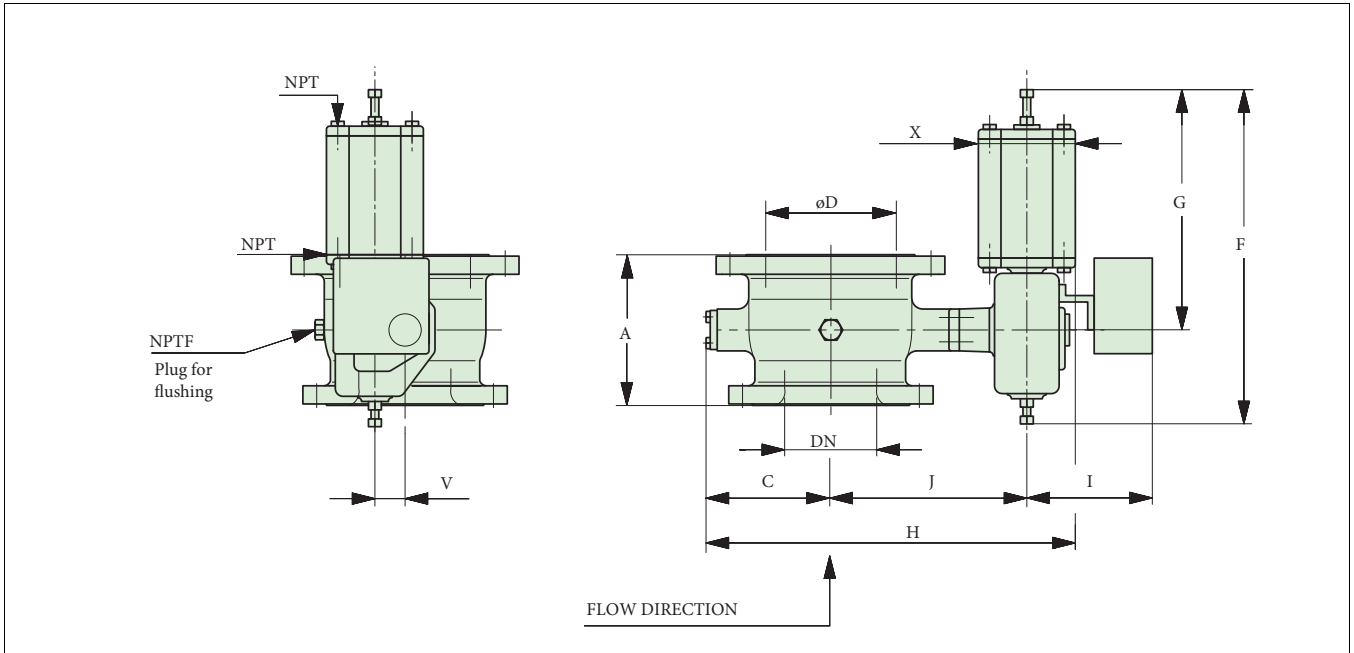

Type	Dimensions, mm													NPT	NPTF	kg
	DN	A	C	D	F	G	X	V	J	J'	H	H'	I			
R2_S 50/80-B1C 6	50	165	91	80	395	270	90	36	256	292	428	463	219	1/4	1/2	19
R2_S 80/100-B1C 9	80	165	108	102	455	315	110	43	221	266	405	450	220	1/4	1/2	30
R2_S100/150-B1C 9	100	163	117	136	455	315	110	43	229	274	425	470	220	1/4	1/2	42
R2_S150/200-B1C 11	150	207	177	190	540	375	135	51	310	340	570	600	225	3/8	1/2	69
R2_S200/250-B1C13	200	248	200	240	635	445	175	65	367	383	665	681	235	3/8	3/4	113
R2_S250/300-B1C17	250	298	252	296	700	470	175	78	420	450	760	790	260	1/2	3/4	170
R2_S300/350-B1C17	300	338	270	336	770	545	215	78	495	530	880	915	340	1/2	3/4	230
R2_S350/400-B1C17	350	400	311	390	770	545	215	78	582	582	1000	1000	340	1/2	3/4	260
R2_S350/400-B1C20	350	400	311	390	840	575	215	97	601	601	1020	1020	355	1/2	3/4	279
R2_S400/450-B1C25	400	400	353	450	1040	710	265	121	691	691	1177	1177	390	1/2	3/4	387
R2_S500/600-B1C25	500	660	508	600	1075	725	265	121	723	723	1286	1286	390	1/2	3/4	580

Note: In case of spring-return actuator need, please contact your local Valmet office

J', H': Dimension with live loading construction

## How to order

### Example:

R2	L	S	100/150	C	J	J	K
1.	2.	3.	4.	5.	6.	7.	8.

1.	Product series
R2	Flanged, reduced bore
2.	Pressure rating
J	PN 10
K	PN 16
L	PN 25
M	PN 40
C	AMSE 150
D	ASME 300
R	JIS 10 K
S	JIS 16 K
T	JIS 20 K
3.	Construction
S	High-consistency version, drive shaft with keyway
4.	Size
	050/080, 080/100, 100/150, 150/200, 200/250, 250/300, 300/350, 350/400, 400/450, 500/600 02/03, 03/04, 04/06, 06/08, 08/10, 10/12, 12/14, 14/16, 16/18, 20/24

5.	Body	Screws
C	CG8M (AISI 317)	A4-80 / B8M
T	Titanium	Titanium
U	CK3MCuN	CK3MCuN
6.	Segment	
J	SIS 2324 (AISI 329) + hard chrome plating	
C	CG8M (AISI 317) + hard chrome plating	
T	Titanium + ceramic coating	
U	CK3MCuN + ceramic coating	
7.	Shafts, pins / bearings	
J	SIS 2324 (AISI 329) / PTFE	
T	Titanium / PVDF	
U	254SMo / PTFE	
8.	Seat	
K	316 + Cobalt based hard facing, back seal PTFE lip seal	
U	Titanium, back seal virgin PTFE lip seal	

Subject to change without prior notice.

Neles, Neles Easyflow, Jamesbury, Stonel, Valcon and Flowrox, and certain other trademarks, are either registered trademarks or trademarks of Valmet Oyj or its subsidiaries in the United States and/or in other countries.

For more information [www.neles.com/trademarks](http://www.neles.com/trademarks)

### Valmet Flow Control Oy

Vanha Porvoontie 229, 01380 Vantaa, Finland.

Tel. +358 10 417 5000.

[www.valmet.com/flowcontrol](http://www.valmet.com/flowcontrol)

