

Neles™ Neldisc™ metal seated butterfly valves

Series L16, L17, L18 and L26, L27, L28

Installation, maintenance and
operating instructions

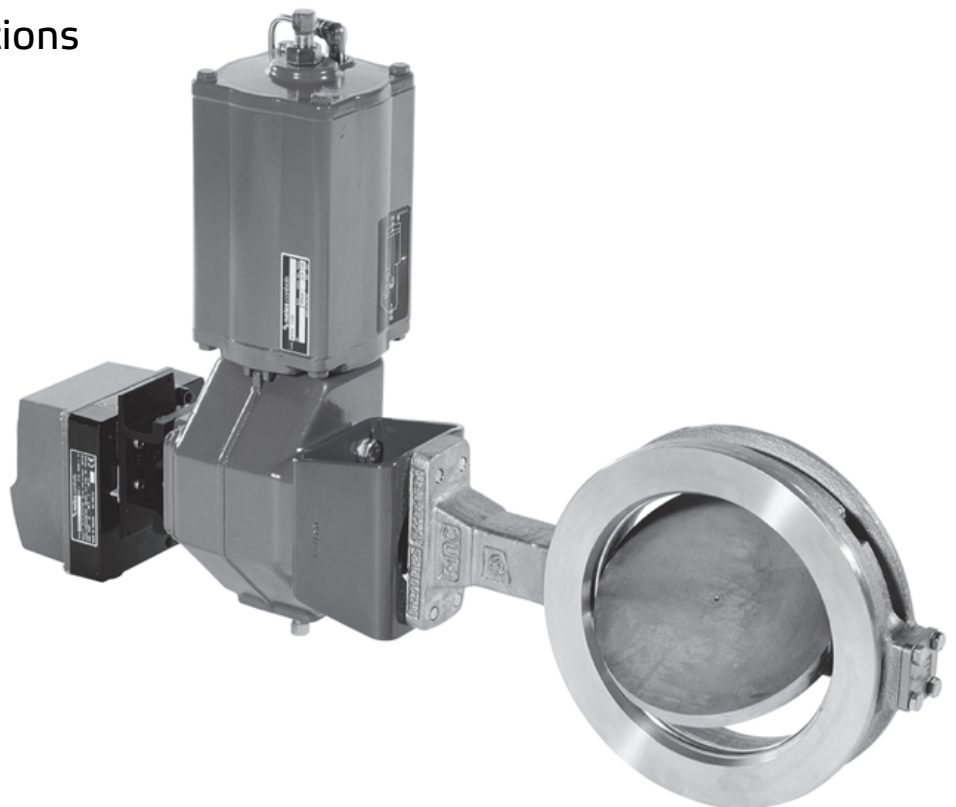

Table of Contents

GENERAL	3	DETACHING AND MOUNTING THE ACTUATOR	9
Scope of the manual	3	General	9
Valve description	3	Detaching the actuator	9
Valve markings	3	Mounting the actuator onto the valve	9
Technical specifications	3	Stop screw adjustment	9
Valve approvals	3	TOOLS	11
CE marking	3	ORDERING SPARE PARTS	11
Recycling and disposal	3	EXPLODED VIEW AND PARTS LIST	14
Safety precautions	3	DIMENSIONS AND WEIGHTS	15
Welding notes	4	TYPE CODE	23
TRANSPORTATION, RECEPTION AND STORAGE	4		
INSTALLATION	4		
General	4		
Mounting into the pipeline	4		
Actuator	6		
COMMISSIONING	6		
SERVICE	6		
General	6		
Removing the valve from the pipeline	6		
Replacing the gland packing	6		
Valve leakage	7		
Replacing the seat ring	7		
Replacing the disc, shafts and bearings	8		
Assembling the valve	8		

READ THESE INSTRUCTIONS FIRST!

These instructions provide information about safe handling and operation of the valve.
If you require additional assistance, please contact the manufacturer or manufacturer's representative.
Addresses and phone numbers are printed on the back cover.

SAVE THESE INSTRUCTIONS!

Subject to change without notice.

All trademarks are property of their respective owners.

1 GENERAL

1.1 Scope of the manual

This installation, operation and maintenance manual provides essential information on series L16, L17, L18, L26, L27 and L28 Neldisc™ butterfly valves. The actuators and instrumentation to be used with series L16, L17, L18, L26, L27 and L28 valves are also discussed briefly. Refer to the separate actuator and control equipment instruction manuals for further information.

NOTE:

Selection and use of the valve in a specific application requires close consideration of detailed aspects. Due to the nature of the product, this manual cannot cover all the individual situations that may occur when installing, using or servicing the valve.

If you are uncertain about the use of the valve or its suitability for your intended use, please contact Valmet for more information.

1.2 Valve description

Neles™ Neldisc™ series L16, L17 and L18 are wafer type and series L26, L27 and L28 are lug type metal seated butterfly valves.

The disc is elliptical and has a double eccentric mounting. When the valve is closed, the elliptical disc at the major axis displaces the seat ring outward, causing the seat ring to contact the disc at the minor axis. When the valve is opened, the contact is released and the seat ring returns to its original circular shape (see Fig. 1).

The disc is fitted to the shafts with pins and there are no holes through the disc.

Construction details of individual valves are included in the type code shown on the valve identification plate. To interpret the type code, please refer to Section 11.

The valve operates both in control and shut-off applications.

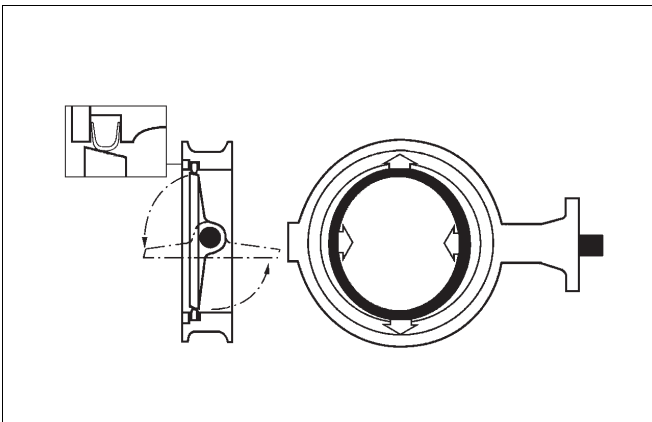

Fig. 1 Construction of a butterfly valve

1.3 Valve markings

Body markings are cast on the body. The valve also has an identification plate attached to it (see Fig. 2).

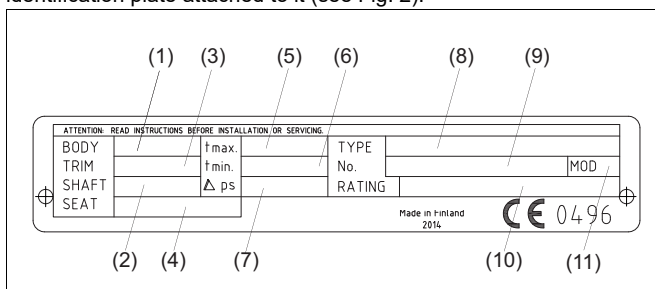

Fig. 2 Example of Identification plate

Identification plate marking:

1. Body material
2. Shaft material
3. Trim material
4. Seat material
5. Maximum operating temperature
6. Minimum operating temperature
7. Maximum shut-off pressure differential
8. Type designation
9. Valve manufacturing parts list no.
10. Pressure class
11. Model

1.4 Technical specifications

Type:	Full bore, metal seated butterfly valve
Pressure class	
Body:	L16L, L17L, L26L, L27L: DIN PN 25 L18M, L28M: ISO PN 50/DIN PN 40
Trim:	L16L, L17L, L26L, L27L, Sizes 80-150: DIN PN 25 Sizes 200-350: DIN PN 20 L18M, L28M: ISO PN 50/DIN PN 40
Temperature range:	-200 °C - +550 °C (for ambient temperatures > 550 °C, please contact the manufacturer)
Flow direction:	Free
Dimensions:	See p. 17-20
Weights:	See p. 17-20

1.5 Valve approvals

Baumuster/Bauteilprüfung (TRB 801 Nr. 45 and VdTÜV-Merkblatt 1065).

The valve meets the requirements of BS 6755, Part 2: 1987 and API 607, Fourth Edition, May 1993 on fire safety.

TA-Luft, chapter 3.1.8.4 approved design as standard (PTFE V-ring and graphite packing).

1.6 CE marking

The valve meets the requirements of the European Directive 2014/68/EU relating to pressure equipment, and has been marked according to the Directive.

1.7 Recycling and disposal

Most valve parts can be recycled if sorted according to material. Most parts have material marking. A material list is supplied with the valve. In addition, separate recycling and disposal instructions are available from the manufacturer. A valve can also be returned to the manufacturer for recycling and disposal against a fee.

1.8 Safety precautions

CAUTION:

Do not exceed the valve performance limitations!

Exceeding the limitations marked on the valve may cause damage and lead to uncontrolled pressure release.

Damage or personal injury may result.

CAUTION:

Do not dismantle the valve or remove it from the pipeline while the valve is pressurized!

Dismantling or removing a pressurized valve will result in uncontrolled pressure release. Always isolate the relevant part of the pipeline, release the pressure from the valve and remove the medium before dismantling the valve.

Be aware of the type of medium involved. Protect people and the environment from any harmful or poisonous substances. Make sure that no medium can enter the pipeline during valve maintenance. Failure to do this may result in damage or personal injury.

CAUTION:

Beware of the discs cutting movement!

Keep hands, other parts of the body, tools and other objects out of the open flow port. Leave no foreign objects inside the pipeline.

When the valve is actuated, the disc functions as a cutting device. The position of the disc can also be changed when moving the valve. Close and detach the actuator pressure supply pipeline for valve maintenance.

Failure to do this may result in damage or personal injury.

CAUTION:

Beware of noise emissions!

The valve may produce noise in the pipeline. The noise level depends on the application. It can be measured or calculated using Neles Nelprof computer program. Observe the relevant work environment regulations on noise emission.

CAUTION:

Beware of a very cold or hot valve!

The valve body may be very cold or very hot during use. Protect yourself against cold injuries or burns.

CAUTION:

When handling the valve or the valve package, bear in mind its weight!

Never lift the valve or valve package by the actuator, positioner, limit switch or their piping.

Place the lifting ropes securely around the valve body (see Fig. 3). Damage or personal injury may result from falling parts.

NOTE:

Do not turn the disc more than 90° as this could damage the seat. The valve is so constructed that the disc operates only between 0-90°.

1.9 WELDING NOTES

WARNING: Welding and/or grinding stainless steel and other alloys containing chromium metal may cause the release of hexavalent chromium. Hexavalent chromium(VI) or Cr(VI), is known to cause cancer. Be sure to use all appropriate personal protective equipment (PPE) when welding metals containing chromium.

NOTE: A qualified welder must do the installation welding. The welder and welding procedure should be qualified in accordance with the ASME Boiler and Pressure Vessel Code Section IX or other applicable regulation.

CAUTION: To prevent damage to the seat and seals, do not allow the temperature of the seat and body seal area to exceed 94 °C (200 °F). It is recommended that thermal chucks be used to check the temperature in these areas during welding.

CAUTION: Ensure that any weld splatter does not fall onto the valve closing members eg. ball or seats. This may damage critical seating surfaces and cause leaks.

2 TRANSPORTATION, RECEPTION AND STORAGE

Check the valve and the accompanying devices for any damage that may have occurred during transport.

Store the valve carefully before installation, preferably indoors in a dry place.

Do not take the valve to the intended location and do not remove the flow port protectors until the valve is installed.

The valve is delivered in the closed position. A valve equipped with a spring-return actuator is delivered in a position determined by the spring. During storage the valve must be lightly closed.

3 INSTALLATION

3.1 General

Remove the flow port protectors and check that the valve is undamaged and clean inside.

CAUTION:

When handling the valve or the valve package, bear in mind its weight!

Follow the lifting methods shown in Fig. 3.

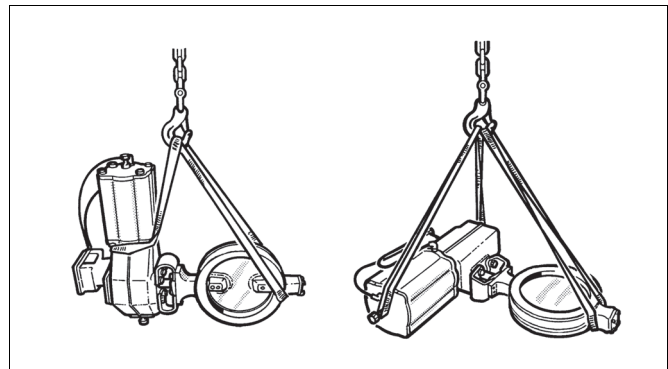

Fig. 3 Lifting of the valve

3.2 Mounting into the pipeline

Flush or blow the pipeline carefully before installing the valve. Foreign particles, such as sand or pieces of welding electrode, will damage the disc sealing surface and seat.

The valve may be installed in any position and offers tightness in both directions.

Install the valve in the pipeline so that the shaft is horizontal if possible. However, we do not recommend installing the valve with the actuator on the underside because dirt in the pipeline may then enter the body cavity and damage the gland packing.

If the valve is equipped with a flow balancing trim (type code S-...), it must be on the down stream side of the valve body. The valve must be mounted so that the perforated plate will not collect any impurities in the pipeline (see Fig. 4).

Select flange gaskets according to the operating conditions.

Do not attempt to correct pipeline misalignment by means of flange bolting.

It may be necessary to firmly support the pipeline to protect the valve from excess stress. Sufficient support will also reduce pipeline vibration and this ensures proper functioning of the positioner. Do not fasten supports to the flange bolting or to the actuator.

It is recommended that the length of any straight pipe preceding the control valve is at least 2 x pipe diameter.

The flow causes a so-called dynamic torque against the valve disc which attempts to close the valve. In a pipe elbow the pressure on the outer edge is higher than on the inner edge.

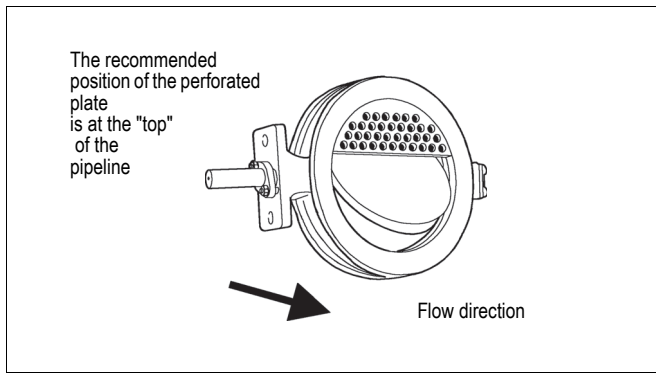

Fig. 4 Position of the flow balancing trim

When installing the butterfly valve immediately after a pipe elbow, the valve shaft must be directed toward the centre point of the pipe (see Fig. 5). This is especially important when the butterfly valve is used as a control valve.

The valve shaft of a butterfly valve mounted after the centrifugal pump must be perpendicular to the pump shaft (see Fig. 6).

When thus installed, the valve discs will be more evenly loaded and vibrations otherwise possible in the intermediate positions will be eliminated.

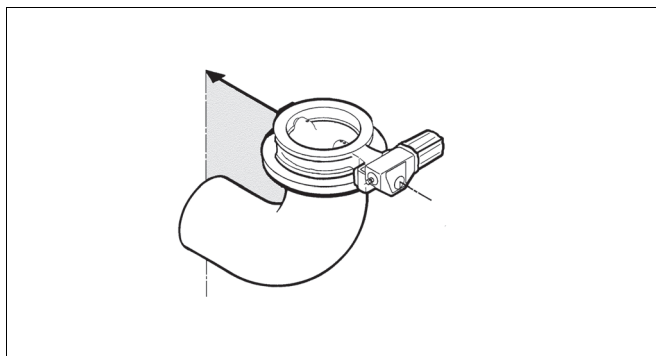

Fig. 5 Mounting after a pipe elbow

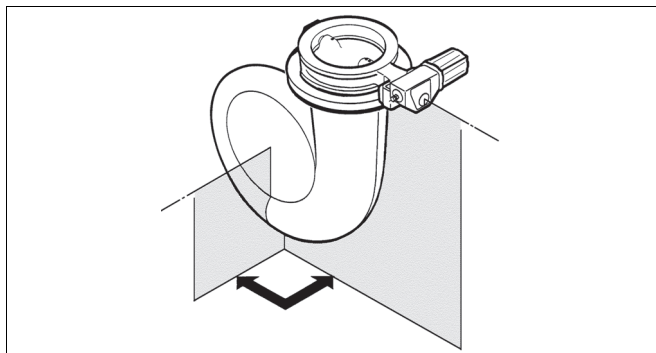

Fig. 6 Mounting after the centrifugal pump

Table 1 Mounting dimensions (mm)

Valve size	D	
	L16L, L17L, L26L, L27L	L18M, L28M
80	68	68
100	89	89
125	115	N.A.
150	142	136
200	190	188
250	242	227
300	288	281
350	327	317

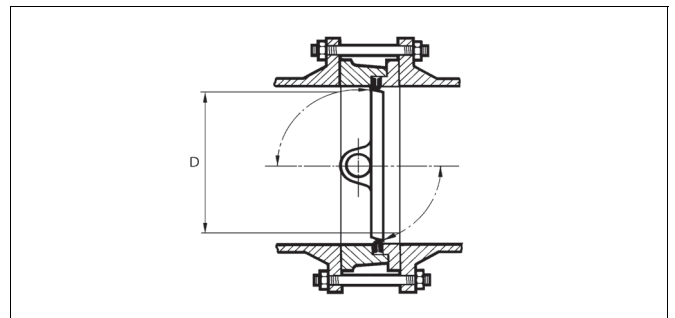

Fig. 7 Mounting dimensions

When mounting the valve it must be in a closed position and be carefully centred between the pipe flanges so that the turning disc does not touch the pipe edge or flange gaskets.

In valves with certain nominal sizes some flange bolts do not pass the valve body. The valve body is thus equipped with holes, see Fig. 2 and Tables 2...4.

Ensure that the disc can turn to the open position after preliminary tightening of the flange bolts. The actuators of control valves can be equipped with position stops which usually only allow the disc to open 80°.

Table 2 Mounting options

Valve type: L16L, L17L					Valve type: L18M			
DN	PN 10	PN 16	ISO PN 20	PN 25	DN	PN 25	PN 40	ISO
80	X	X	X	X				PN 50
100	X	X	X	X	80	X	X	X
125	X	X	X	X	100	X	X	X
150	X	X	X	X	150	X	X	X
200	X	X	X	X	200	UH	UH	UH
250	X	X	X	X	250	SB	SB	SB
300	X	X	X	X	300	SB	SB	SB
350	UH	UH	UH	UH	350	SB	UH	SB

Mounting options

- X Flange bolts pass the neck of the body
- UH Unthreaded holes at the neck of the body
- SB Stud bolts at the neck of the body

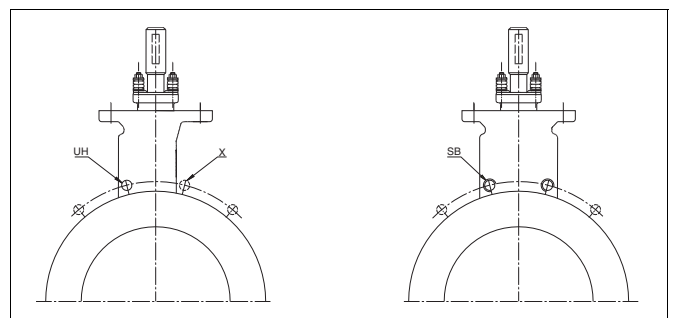

Fig. 8 Mounting options

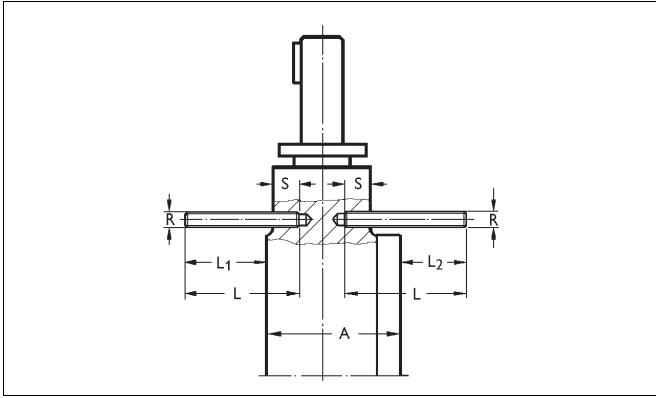

Fig. 9 Stud bolt mounting dimensions, mounting options SB

Table 3 Stud bolt dimensions (mm), mounting option SB

Valve type	A															
		R	L	L1	L2	S	R	L	L1	L2	S	R	L	L1	L2	S
L18M 250	114	M27	110	76	75	30	M30	120	86	84	30	M27	120	95	93	22
L18M 300	114	M27	110	85	78	20	M30	120	96	88	20	M30	130	106	95	20
L18M 350	127	M30	115	88	86	22	M33	125	98	96	22	M30	135	108	106	22

3.3 Actuator

When installing the actuator on the valve, make sure that the valve package functions properly. See instructions for installing in Section 6. Observe the space needed for removal of the actuator.

The upright position is recommended for the actuator cylinder.

The actuator must not touch the pipeline, because pipeline vibration may damage it or interfere with its operation.

In some cases, e.g. when a large-size actuator is used or when the pipeline vibrates heavily, supporting the actuator is recommended. Please contact Valmet for further information.

4 COMMISSIONING

Ensure that no dirt or foreign objects are left inside the valve or pipeline. Flush the pipeline carefully. Keep the valve 30-40° open during flushing.

When starting up the pump, ensure that the valve in the pipeline is closed or, at the very most, 20° open.

A waterhammer, which follows the start-up of high-capacity pumps, creates a torque peak in the disc. This can damage the pin connection between disc and shaft when the valve is 30-90° open.

The packing construction is live loaded. So tightening the packing screws during service is not necessary.

5 SERVICE

CAUTION:

Observe the safety precautions listed in Section 1.8 before starting work!

CAUTION:

For safety reasons the retaining plates **MUST** always be installed according to Section 5.2.



5.1 General

Butterfly valves require no regular maintenance. If the valve should require maintenance for some reason, a few simple service measures are normally sufficient.

The numbers in parentheses refer to the parts list and the exploded

view of the valve in Section 9.

NOTE:

If you send the valve to the manufacturer for repair, do not dismantle it. Clean the valve carefully, including the inside. For safety reasons, inform the manufacturer of the type of medium used in the valve.

NOTE:

Always use original spare parts to ensure that the valve functions as intended.

5.2 Removing the valve from the pipeline

CAUTION:

Do not dismantle the valve or remove it from the pipeline while the valve is pressurized!

It is generally most convenient to detach the actuator and its auxiliary devices (see Section 6), before removing the valve from the pipeline. If the valve package is small or difficult to access, it may be more practical to remove the entire package at the same time.

Ensure that the valve is not pressurized and the pipeline is empty. Ensure that the medium cannot flow into the section where servicing is to take place. The valve must be in a **closed position** when removing.

Support the valve carefully with a hoist. Place ropes carefully and unscrew the pipe flange bolts. Ensure that the ropes are positioned correctly (see Fig. 3). Lift valve correctly (see Fig. 3).

5.3 Replacing the gland packing

CAUTION:

Do not dismantle the valve or remove it from the pipeline while the valve is pressurized!

PTFE V-rings are used as a standard gland packing and graphite rings for high temperature constructions. The packing construction is live loaded as standard. So tightening the packing screws during service is not necessary.

The gland packing (20) must be changed if leakage occurs even after the hex nuts (25) have been tightened.

- Make sure the valve is not pressurized.
- Unfasten the nuts (25) and remove the TA-Luft kits (44), the retaining plates (42) and the gland (9).

- Remove old packing rings (20). Do not damage the surfaces of the packing ring counterbore and shaft. It is not necessary to change anti-extrusion ring (22) and sheet ring (21).
- Clean the gland packing and packing ring counterbore. Install new set of packings (V-ring or graphite). Slip the graphite rings onto the shaft. Ensure that there are no burrs in the keyway groove which could damage the packing.
- Install the gland.
- Mount the retaining plates with the text UPSIDE on top (see Fig. 10).

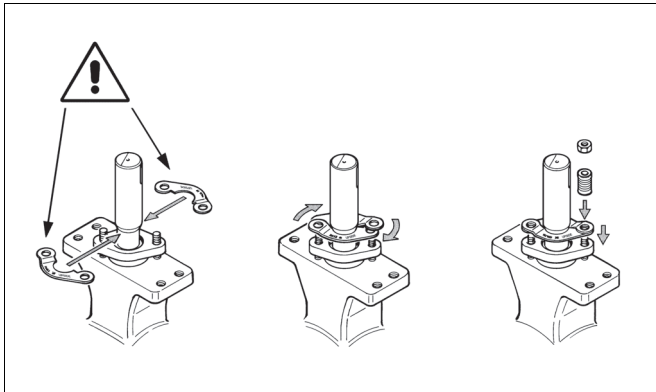

Fig. 10 Mounting the retaining plate

Table 4 Gland packing nut tightening torques

PTFE V-ring				
L16L, L26L, L17L, L27L	L18M, L28M	Shaft diameter	Thread	Torque
DN	DN	mm		Nm
80	80	15	M8	3.5
100, 125, 150	100	20	M8	4.3
200	150	25	M10	9.3
250	-	30	M10	10.8
300	200	35	M10	12.2
350	-	40	M10	13.7
	250	45	M12	21
	300	50	M12	23
	350	55	M12	25

Graphite packing				
L16L, L26L, L17L, L27L	L18M, L28M	Shaft diameter	Thread	Torque
DN	DN	mm		Nm
80	80	15	M8	7.4
100, 125, 150	100	20	M8	9.3
200	150	25	M10	13.3
250	-	30	M10	15.4
300	200	35	M10	17.5
350	-	40	M10	19.6
	250	45	M12	32.3
	300	50	M12	35.4
	350	55	M12	38.5

- Mount the TA-Luft kits.
- Place the nuts on the studs and tighten the gland packings while the valve is not pressurized. Use recommended torques, which are values of lubricated nuts (see Table 4).

5.4 Valve leakage

Valve leakage is not always caused by a damaged seat ring or disc. The reason can also be that the disc is not in the closed position.

- Check the position of the actuator relative to the valve. The screws may be loose or the bracket damaged.

- Check the adjustment in the closed position (see Section 6.4). The marking line parallel to the disc on the valve shaft head shows roughly the closed position of the disc (see Fig. 12).

Pressure chocks can cause loosening of the pin connection between disc and shaft; consequently the shaft moves while the disc remains in place and this prevents full closing of the disc.

If the reason for the leakage does not become apparent after doing the above, the valve must be disassembled

5.5 Replacing the seat ring

CAUTION:
Do not dismantle the valve or remove it from the pipeline while the valve is pressurized!

- Ensure that the valve is not pressurized.
- Remove the valve from the pipeline. The valve must be in a closed position during removal. Follow the lifting methods shown in Section 3.
- Remove the clamp ring (2) by untightening the screws (27).
- Remove the old body seal (19) and the seat ring (4). Change the seat ring if it is damaged.
- Clean all the surfaces of the seats and check the surface of the seat ring.
- Check also the condition of the disc. A damaged disc must be changed (see Section 5.5).
- Check the condition of the pin connection. Repair it if necessary (see Section 5.5).
- Mount a new, self-adhesive body seal (19) into the body. The surface must be clean and free of grease. Handle the ends of the seal according to Fig. 11.

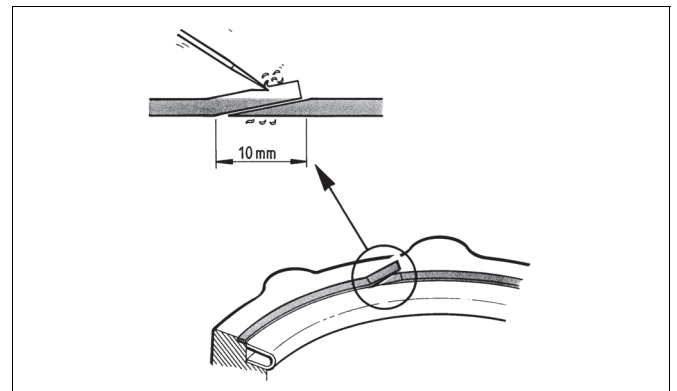

Fig. 11 Mounting the body seal

- Spray a thin layer of dry lubricating fluid, e.g. Molykote 321R or equivalent, into the seat groove, surfaces of the clamp ring and seat ring.
- Centre the seat ring (4) carefully into its groove and turn the disc to maintain light contact with the seat.
- Mount the clamp ring and tighten the screws (27) lightly.
- Turn the disc slightly open and pull it back to set the seat into the proper position.
- Tighten the screws (27) evenly. An unevenly tightened flange may damage the seat ring. The screw heads must be below the flange surface in lug type valves.
- Check the position between the seat ring and the disc. The valve closes clockwise (see Fig. 12).
- Mount the actuator into the valve. Adjust the closed position limit and check the open position limit (see Section 6.4).

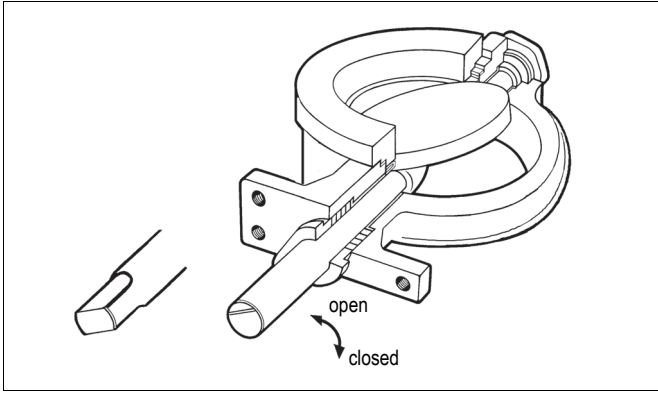

Fig. 12 Open and closed positions of the valve

5.6 Replacing the disc, shafts and bearings

Disassembling the valve

The pin connection of the disc must be opened by drilling for changing the disc (3), shafts (11, 12) and bearings (15, 16).

- Remove the valve from the pipeline and the actuator from the valve.
- Remove the clamp ring (2) and seat ring (4) according to section 5.4.
- Set the valve horizontally on a sturdy surface so that the flat side of the disc lays against the surface (see Fig. 13).

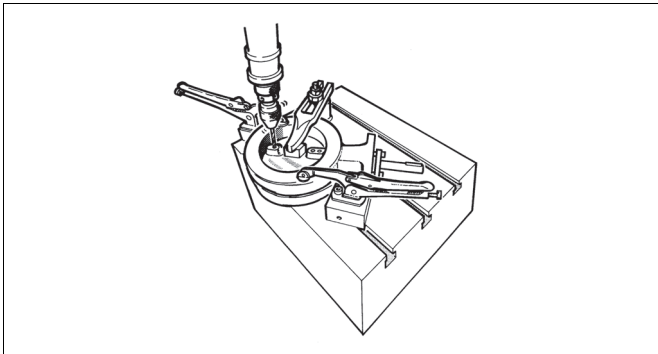

Fig. 13 Drilling the pins

- Drill the holes carefully to the centre of the pins (14). Choose a drill 0.2-0.5 mm smaller than the diameter of the pin.
- Drill the holes deep, but not enough to reach the disc.
- Pull the pins out.
- Dismantle the gland packing including anti-extrusionring (22) and sheet ring (21) according to Section 5.2.
- Detach the screws (26) and the blind flange (10) and remove the gasket (18).
- Place rubber strips or other protection between the disc edge and the body and remove the shafts (see Fig. 14).
- Remove the bearings (15, 16).
- Clean and check all parts carefully.

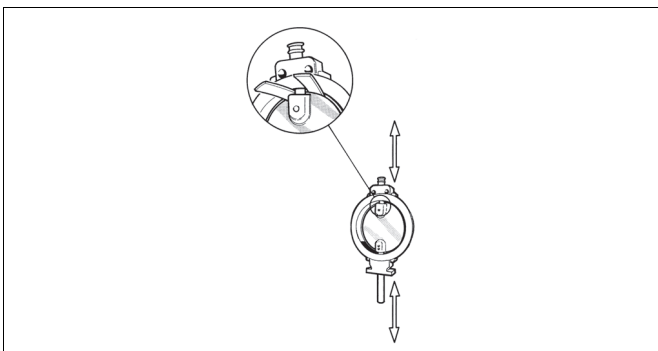

Fig. 14 Protecting the disc during disassembly and assembly

5.7 Assembling the valve

- Replace damaged parts with new ones.
- Set the disc and the shaft together beforehand. In case the pin holes have been damaged during removal of the old pins the holes can be drilled to a larger pin size. File off any burrs from the shafts.

The bearing material of the standard construction valves is PTFE-impregnated stainless steel net.

The bearings for the high temperature valves (N and H-constructions) are cobalt alloy bushings which are mounted into the body together with the shafts.

- Mount the bearings into the body (see Fig. 15).

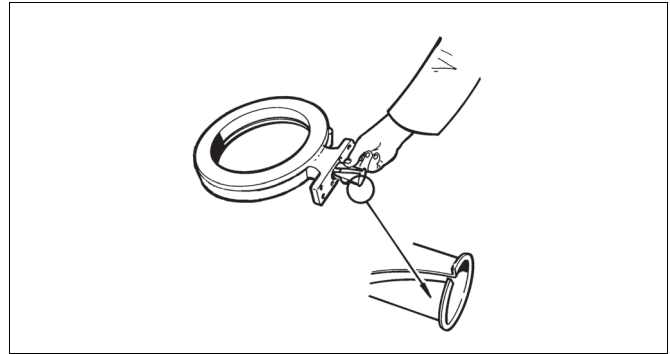

Fig. 15 Mounting the standard bearings

- **High temperature-construction:** Mount the bearing into the shaft. Spray a thin layer of dry lubricating fluid, e.g. Molykote 321R or equivalent, into the inside surface of the bushing and the shaft bearing groove. Press the bushing with a tightening ring into the shaft bearing groove and fit the shaft with the bearings carefully into the body through the tightening ring (see Fig. 16).
- Place the disc horizontally on a surface so that the flat side of the disc lays against the surface. Lift the body around the disc so that the shaft bores are aligned with the bores in the disc. Protect the disc (see Fig. 14).
- Press the shafts into the disc drillings. Align the pin holes. The shaft (11) position against the disc must be according to Fig. 12.

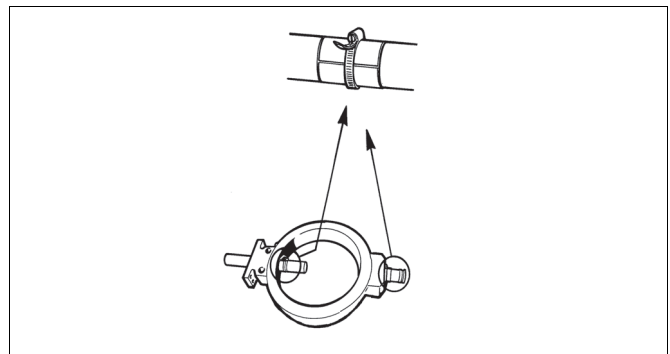

Fig. 16 Mounting the metal bearings

NOTE:

Use only pins supplied by the manufacturer!

NOTE:

The pins must be pressed with enough force to deform them so that the connection will be free from backlash.

- Support the disc well in a horizontal position during mounting of the pins. Push the new pins into the holes and press them in a press to final form (see Fig. 17). Use a smaller tool than the pin diameter. See Table 5 for forces.
- Install the gasket (18) and the blind flange (10).
- Screws of the blind flange must be tightened evenly. An unevenly tightened flange will damage the seat.
- Install the seat ring. See details in Section 5.4.

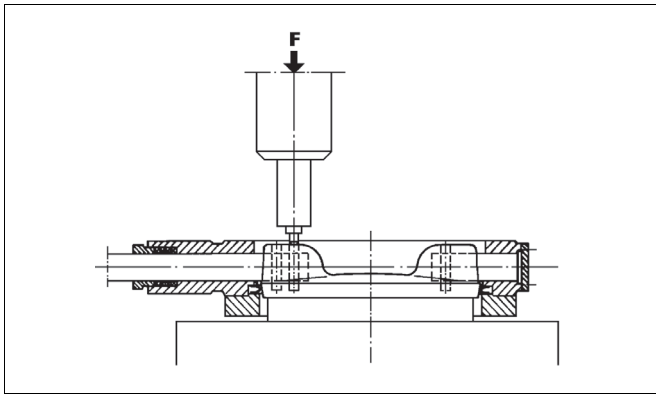

Fig. 17 Pressing the pins

Table 5 Pressing the pins, forces

Pin diameter, mm	Force, kN	Pin diameter, mm	Force, kN
5	45	10	125
6	60	12	180
8	80	15	280

- Install the body seal (19) and the clamp ring (2). See details in Section 5.4.
- Install the gland packing (see Section 5.2).
- Check the contact line between the seat ring and the disc (see Fig. 12).

6 DETACHING AND MOUNTING THE ACTUATOR

6.1 General

CAUTION:

When handling the valve or the valve package, bear in mind its weight!

NOTE:

Do not turn the disc more than 90° as this could damage the seat. The valve is so constructed that the disc operates only between 0-90°.

6.2 Detaching the actuator

CAUTION:

The actuator cannot be removed from the valve when the pipeline is under pressure as a result of dynamic torque!

NOTE:

Before dismantling, carefully observe the position of the valve with respect to the actuator and positioner/limit switch so as to ensure that the package can be properly reassembled.

The actuator is factory-mounted on the valve and the stroke limit stop screws are adjusted in advance. As a result of the dynamic torque the actuator can not be removed from the valve when the pipeline is under pressure.

- Disconnect the actuator from its power source; detach the air supply pipe and control signal cables or pipes from their connectors.
- Unscrew the bracket screws.
- Detach the actuator using a suitable extractor. The correct tool can be ordered from the manufacturer (see Fig. 18).
- Remove the bracket and coupling, if any.

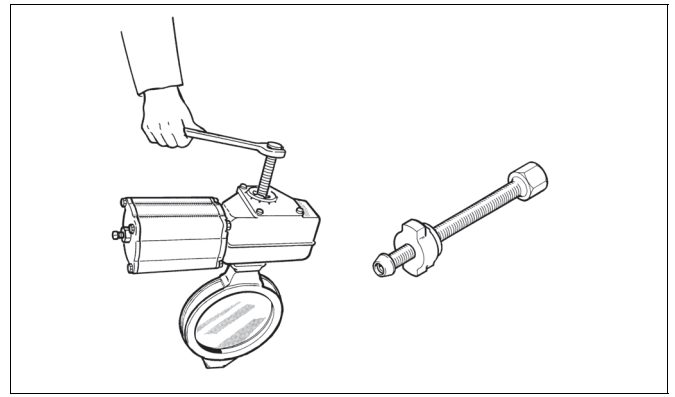

Fig. 18 Removing the actuator with an extractor

6.3 Mounting the actuator onto the valve

- Turn the valve to the closed position before mounting the actuator.
- Clean the shaft and the shaft bore and file off any burrs which could interfere with mounting. Protect the joint surfaces from corrosion, e.g. with Cortec VCI 369.
- If a bushing is required between the actuator shaft bore and the valve shaft, mount it first in the actuator shaft bore.
- The valve keyway is on the side opposite the flat side of the disc. The actuator shaft bore has two keyways set 90° apart.
- For double-acting cylinder actuator, B1C, and spring-return cylinder actuator, B1J (spring-to-close), choose the keyway which establishes the piston in its upper position (at the top end of the cylinder) when the valve is closed.

In the spring-return cylinder actuator B1JA (spring-toopen), choose the keyway which establishes the piston in its lower position when the valve is open.

In valves with manual operation the disc must be closed by turning the handwheel clockwise.

- Check visually that the actuator is correctly positioned relative to the valve. Tighten all the fastening screws as tightly as possible.
- Adjust the stop screws to the closed position (see Section 6.4).
- The opening angle in a control valve is usually limited by a bolt to 80°. The opening angle of a shut-off valve is 90°.
- When a shaft extension is required, the sizing of the shaft extension must be discussed with the valve manufacturer.

6.4 Stop screw adjustment

General

Close the metal seated butterfly valve by turning the disc with a torque against the seat. Choose the torque from Tables 7-8 for adjusting the stop screw to the closed position of the actuator.

Try not to exceed the given values since excessive torque would strain the seat and the joint between the disc and the shaft.

Always readjust the stop screw after changing the seat and after mounting the actuator.

Actuators other than tabulated

Close the valve as per the tabulated torque M_c and adjust the stops accordingly. Note the increased torque created by the actuator while the valve is closed.

NOTE:

Valmet accepts no responsibility for compatibility of actuators not installed by Valmet.

Changing the mounting position

CAUTION:
The actuator must not be removed from the valve in a pipeline under pressure as result of dynamic torque!

Always remove the actuator from the valve shaft before mounting it into another key groove. Readjust the closed position limit as instructed.

If manually operated, the valve should close when the handwheel is turned clockwise. In a double-action cylinder, the piston must be in the upper position of the cylinder when the valve is closed. In this position the actuator creates maximum torque. **Do not turn the disc more than 90° as this could damage the seat.**

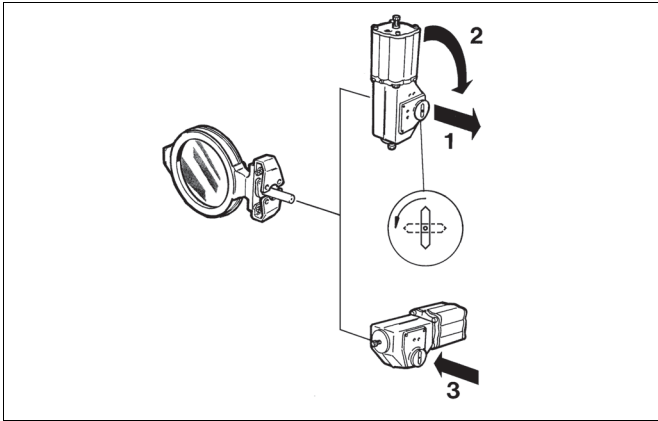

Fig. 19 Changing the mounting position

Double-acting cylinder actuator B1C

- Apply the tabulated shut-off pressure P_c to the air connection at the cylinder base.
- With the stop screw removed, check through the air connection hole that the piston does not touch the cylinder end. If it does, loosen the bracket screws and turn the actuator clockwise to increase the adjusting margin.
- Turn the closed position stop screw until it touches the piston, then turn back 1/4 turn and lock up. An O-ring is used for sealing of the screw.
- An extra long screw is needed for opening angles < 80°.

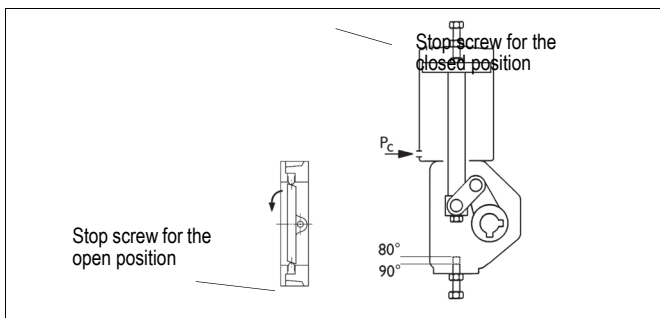

Fig. 20 Cylinder actuator, series B1C

M-series operator

- Close the valve as per the tabulated primary torque M1 (handwheel torque) given in Tables 7-8.
- Tighten the closed position stop screw until it touches the linkage, then turn back 1/4 turn and lock up with Loctite 225.

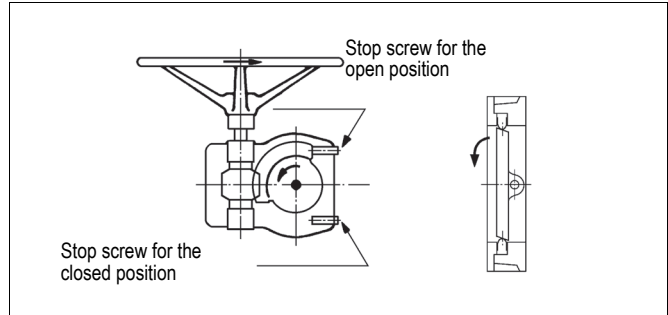

Fig. 21 Actuator, series M

Hand lever RH

- Mount the hand lever on the valve, but do not fasten hex screws (A). Turn the lever using force F in Table 6.
- When closing torque is applied, turn the housing (B) cog of the closing limit to contact with the lever arm. Fasten hex screws (A).

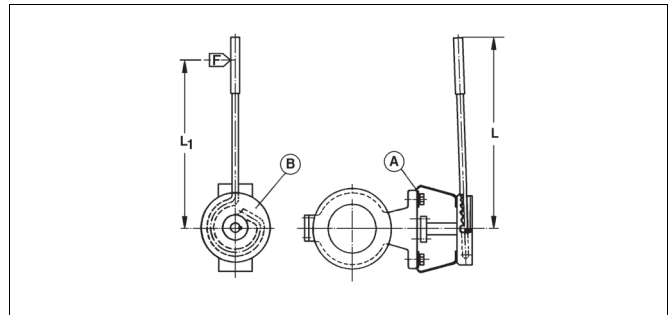

Fig. 22 Hand lever, series RH

Table 6 Hand lever RH, adjustment values

Size	L	L1	Torque		Force	
			Nm	Lbf ft	N	Lbf
80	400	350	40	30	115	26
100	400	350	70	52	200	45
125	400	350	100	74	285	63
150	500	450	135	100	300	67

Electric operator

Instructions for adjustment are given in a separate leaflet code D304568, which is available from the manufacturer.

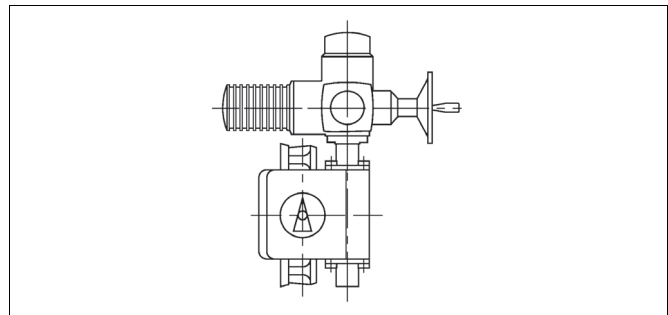

Fig. 23 Electric operator

Spring-return cylinder actuator B1J

Spring-to-close

- Before mounting the cylinder, screw in the closed position stop screw completely.
- The table overleaf indicates *) spring when the spring created torque does not exceed the maximum permitted closing torque M_c . Otherwise, apply the tabulated pressure P_c into the air connection at the cylinder end against the spring force. **The stop screw cannot be removed when the cylinder is pressurized!** Open the stop screw until it does not touch the piston.
- Turn the closed position stop screw until it touches the piston, then turn back 1/4 turn and lock up. An O-ring is used for sealing of the screw.
- After adjusting, check the adjusting margin through the air connection hole. The piston must not touch the cylinder end. If necessary, increase the margin by loosening the bracket screws and turning the actuator clockwise.
- En extra long screw is needed for opening angles $< 80^\circ$.

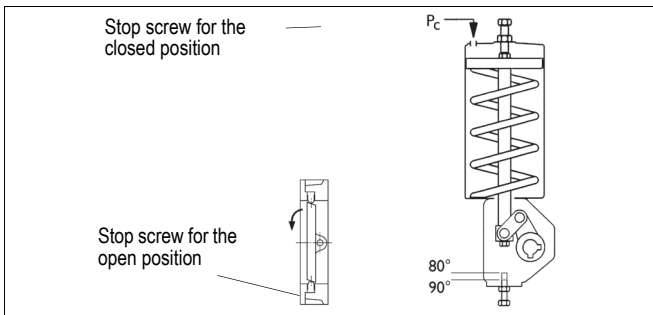

Fig. 24 Cylinder actuator, series B1J

Spring-return cylinder actuator B1JA

Spring to open

- The actuator being unpressurized the valve is open. Unscrew the close limit stop screw (actuator housing). Apply tabulated shut-off pressure P_c to the air connection at the cylinder bottom end against the spring force to close the valve.
- Check through the stop screw hole that the piston rod does not touch the cylinder top end. If it does, loosen the bracket screws and turn the actuator clockwise to increase the adjusting margin.
- Turn the closed position stop screw until it touches the piston, then turn back 1/4 turn and lock up. An O-ring is used for sealing of the screw.
- An extra long screw is needed for opening angles $< 80^\circ$.

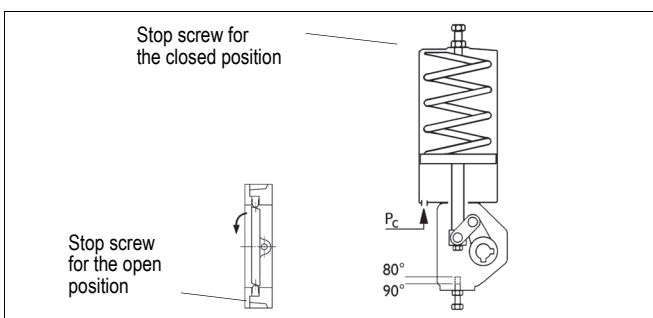

Fig. 25 Cylinder actuator, series B1JA

7 TOOLS

No special tools are needed for servicing the valve.

However, we recommend an extractor for removing the actuator from the valve. The tool can be ordered from the manufacturer.

8 ORDERING SPARE PARTS

When ordering spare parts, always include the following information:

- type code, sales order number, serial number (stamped on a valve body)
- number of the parts list, part number, name of the part and quantity required

This information can be found from the identification plate or documents.

Table 7 Series L16L, L17L, L26L and L27L, closing torques

Size	Closing torque Mc (Nm/lbf ft)	B1C and B1J actuator	B1C supply pressure Pc (bar/psi)	B1J spring-to-close Pc (bar/psi)	B1JA spring-to-open Pc (bar/psi)	B1JK spring-to-close Pc (bar/psi)	B1JKA spring-to-open Pc (bar/psi)	B1JV spring-to-close Pc (bar/psi)	B1JVA spring-to-open Pc (bar/psi)	Quadra-Powr			Manual operator	Primary torque M1 Handwheel (Nm / lbf ft)	
										actuator	spring-to-close Pc (bar / psi)	spring-to-open Pc (bar / psi)			
80	45 / 33	6	2.5 / 36	-	-	-	-	-	-	-	QP2C	0.6 / 9	3.6 / 52	M7	4 / 3
		8	2.1 / 30	0.7 / 10	3.3 / 48	0.3 / 4	2.8 / 41	1.1 / 16	4 / 58	QP3C	1.1 / 16	3.2 / 46			
		10	1.6 / 23	1.1 / 16	2.8 / 41	0.7 / 10	2.2 / 32	1.6 / 23	3.4 / 49						
100	75 / 55	6	4.1 / 59	-	-	-	-	-	-	-	QP2C	-	4.3 / 62	M7	7 / 5
		8	3.4 / 49	0.2 / 3	3.8 / 55	*) spring	3.3 / 48	0.6 / 9	4.6 / 68	QP3C	0.8 / 12	3.5 / 51			
		9	2.1 / 30	-	-	-	-	-	-	-	-	-			
		10	1.9 / 28	0.9 / 13	3.1 / 45	0.5 / 7	2.6 / 38	1.4 / 20	3.7 / 54						
		11	1.1 / 16	-	-	-	-	-	-	-	-	-			
125	110 / 80	6	6 / 87	-	-	-	-	-	-	-	QP3C	0.3 / 4	3.9 / 57	M7	10 / 7
		8	5 / 72	*) spring	4.5 / 65	-	3.8 / 55	*) spring	5.3 / 77	QP4C	1 / 14	3.3 / 48			
		9	3 / 43	-	-	-	-	-	-	-	-	-			
		10	2.4 / 35	0.6 / 9	3.4 / 49	0.2 / 3	2.9 / 42	1.1 / 16	4 / 58						
		11	1.5 / 22	-	-	-	-	-	-	-	-	-			
		12	1.3 / 19	1.1 / 16	3 / 43	0.7 / 10	2.2 / 32	1.6 / 23	3.7 / 54						
150	150 / 110	6	8.2 / 119	-	-	-	-	-	-	-	QP3C	-	4.3 / 62	M7	14 / 10
		9	4.1 / 59	0.2 / 3	3.8 / 55	*) spring	3.2 / 46	0.8 / 12	4.3 / 62	QP4C	0.8 / 12	3.5 / 51			
		10	3.3 / 48	-	-	-	-	-	-	-	-	-			
		11	2.1 / 30	-	-	-	-	-	-	-	-	-			
		12	1.6 / 23	0.9 / 13	3.1 / 45	0.5 / 7	2.6 / 38	1.5 / 22	3.9 / 81						
200	300 / 220	10	6.5 / 94	*) spring	5 / 72	-	4.4 / 64	*) spring	5.6 / 81	QP4C	-	4.3 / 62	M10	27 / 20	
		11	4.2 / 61	-	-	-	-	-	-	QP5C	0.8 / 12	3.5 / 51			
		12	3.3 / 48	0.2 / 3	3.8 / 55	*) spring	3.2 / 46	0.8 / 12	4.6 / 68						
		13	2.1 / 30	-	-	-	-	-	-	-	-	-			
		16	1.6 / 23	0.9 / 13	3.1 / 45	0.5 / 7	2.6 / 38	1.3 / 19	3.8 / 55						
250	500 / 370	12	5.5 / 80	*) spring	4.6 / 67	-	4 / 58	*) spring	5.5 / 80	QP5C	0.1 / 1	4.1 / 59	M12	44 / 32	
		13	3.5 / 51	-	-	-	-	-	-	-	-	-			
		16	2.8 / 41	0.5 / 7	3.6 / 52	*) spring	3 / 43	1 / 14	4.3 / 62						
		17	1.8 / 26	-	-	-	-	-	-	-	-	-			
300	825 / 610	13	5.8 / 84	-	-	-	-	-	-	-			M14	51 / 38	
		16	4.5 / 65	*) spring	4.2 / 61	-	3.6 / 52	0.3 / 4	5 / 73						
		17	3 / 43	-0.6 / 9	-	-	-	-	-	-	-	-			
		20	2.3 / 33	-	3.4 / 49	0.2 / 3	2.8 / 41	1.1 / 16	3.9 / 57						
350	1160 / 860	16	6.4 / 93	*) spring	4.9 / 71	-	4.3 / 62	*) spring	5.7 / 83				M14	72 / 53	
		17	4.2 / 61	-	-	-	-	-	-	-	-	-			
		20	3.3 / 48	0.3 / 4	3.7 / 54	*) spring	3.1 / 45	0.8 / 12	4.2 / 61						
		25	1.7 / 25	0.9 / 13	3.1 / 45	0.5 / 7	2.6 / 38	1.4 / 20	3.6 / 52						

*) Spring torque not adequate to achieve tightness according to DIN

3230 Part 3 Rate 2 (BN), ISO 5208 Rate C,

BS 6755 Part 1 Rate D, ANSI/FCI 70.2 Class V, IEC 534-4 or

MSSSP72 / 1970.

Table 8 Series L18M and L28M closing torques

Size	Closing torque Mc (Nm/lbf ft)	B1C and B1J actuator	B1C supply pressure Pc (bar/psi)	B1J spring-to- close Pc (bar/psi)	B1JA spring-to- open Pc (bar/psi)	B1JK spring-to- close Pc (bar/psi)	B1JKA spring-to- open Pc (bar/psi)	B1JV spring-to- close Pc (bar/psi)	B1JVA spring-to- open Pc (bar/psi)	Quadra-Powr			Manual operator	Primary torque M1 Handwheel (Nm / lbf ft)
										actuator	spring-to- close Pc (bar / psi)	spring-to- open Pc (bar / psi)		
80	45 / 33	6 8 10	2.5 / 36 2.1 / 30 1.6 / 23	- 0.7 / 10 1.1 / 16	- 3.3 / 48 2.8 / 41	- 0.3 / 4 0.7 / 10	- 2.8 / 41 2.2 / 32	- 1.1 / 16 1.6 / 23	- 4 / 58 3.4 / 49	QP2C QP3C	0.6 / 9 1.1 / 16	3.6 / 52 3.2 / 46	M7	4 / 3
100	75 / 55	6 8 9 10 11	4.1 / 59 3.4 / 49 2.1 / 30 1.9 / 28 1.1 / 16	- 0.2 / 3 - 0.9 / 13 -	- 3.8 / 55 - 3.1 / 45 -	*) spring - 0.5 / 7 -	- 3.3 / 48 - 2.6 / 38 -	- 0.6 / 9 - 1.4 / 20 -	- 4.6 / 68 - 3.7 / 54 -	QP2C QP3C	- 0.8 / 12	4.3 / 62 3.5 / 51	M7	7 / 5
150	230 / 170	10 11 12 13 16	5 / 72 3.2 / 46 2.5 / 36 1.6 / 23 1.3 / 19	*) spring - 0.5 / 7 - 0.9 / 13	4.4 / 64 - 3.5 / 51 - 3 / 43	- - 0.1 / 1 - 0.6 / 9	- 3.8 / 55 2.9 / 42 - 2.3 / 33	0.1 / 1 - 1.1 / 16 - 1.5 / 22	5 / 73 - 4.3 / 62 - 3.7 / 54	QP4C QP5C	0.3 / 4 1 / 14	3.9 / 57 3.3 / 48	M10	21 / 15
200	460 / 340	11 12 13 16 17 20	6.4 / 93 5 / 72 3.2 / 46 2.5 / 36 1.7 / 25 1.4 / 20	- *) spring - 0.5 / 7 - 1 / 14	- 4.4 / 64 - 3.5 / 51 - 2.9 / 42	- - 0.1 / 1 - 0.6 / 9	- 3.8 / 55 2.9 / 42 - 2.3 / 33	- 0.1 / 1 - 1 / 14 - 1.5 / 22	- 5.3 / 77 - 4.2 / 61 - 3.5 / 51	QP5C	0.3 / 4	3.9 / 57	M14	28 / 21
250	800 / 590	13 16 17 20	5.6 / 81 4.4 / 64 2.9 / 42 2.3 / 33	- *) spring - 0.7 / 10	- 4.2 / 61 - 3.3 / 48	- - 0.3 / 4	- 3.6 / 52 2.8 / 41	- 0.4 / 6 - 1.2 / 17	- 4.9 / 71 - 3.8 / 55				M14	49 / 36
300	1250 / 920	17 20 25	4.6 / 67 3.6 / 52 1.8 / 26	- 0.2 / 3 0.8 / 12	- 3.8 / 55 3.2 / 46	*) spring - 0.4 / 6	- 3.2 / 46 2.6 / 38	- 0.7 / 10 1.3 / 19	- 4.3 / 62 3.7 / 54				M15	61 / 45
350	1750 / 1290	17 20 25 32	6.4 / 93 5 / 72 2.6 / 38 1.3 / 19	- *) spring 0.6 / 9 1 / 14	- 4.3 / 62 3.4 / 49 2.9 / 42	- - 0.2 / 3 0.6 / 9	- 3.7 / 54 2.9 / 42 2.3 / 33	- 0.2 / 3 1.1 / 16 1.5 / 22	- 4.8 / 70 3.9 / 57 3.6 / 52				M15	85 / 63

*) Spring torque not adequate to achieve tightness according to DIN

3230 Part 3 Rate 2 (BN), ISO 5208 Rate C,

BS 6755 Part 1 Rate D, ANSI/FCI 70.2 Class V, IEC 534-4 or
MSSSP72 / 1970.

9 EXPLODED VIEW AND PARTS LIST

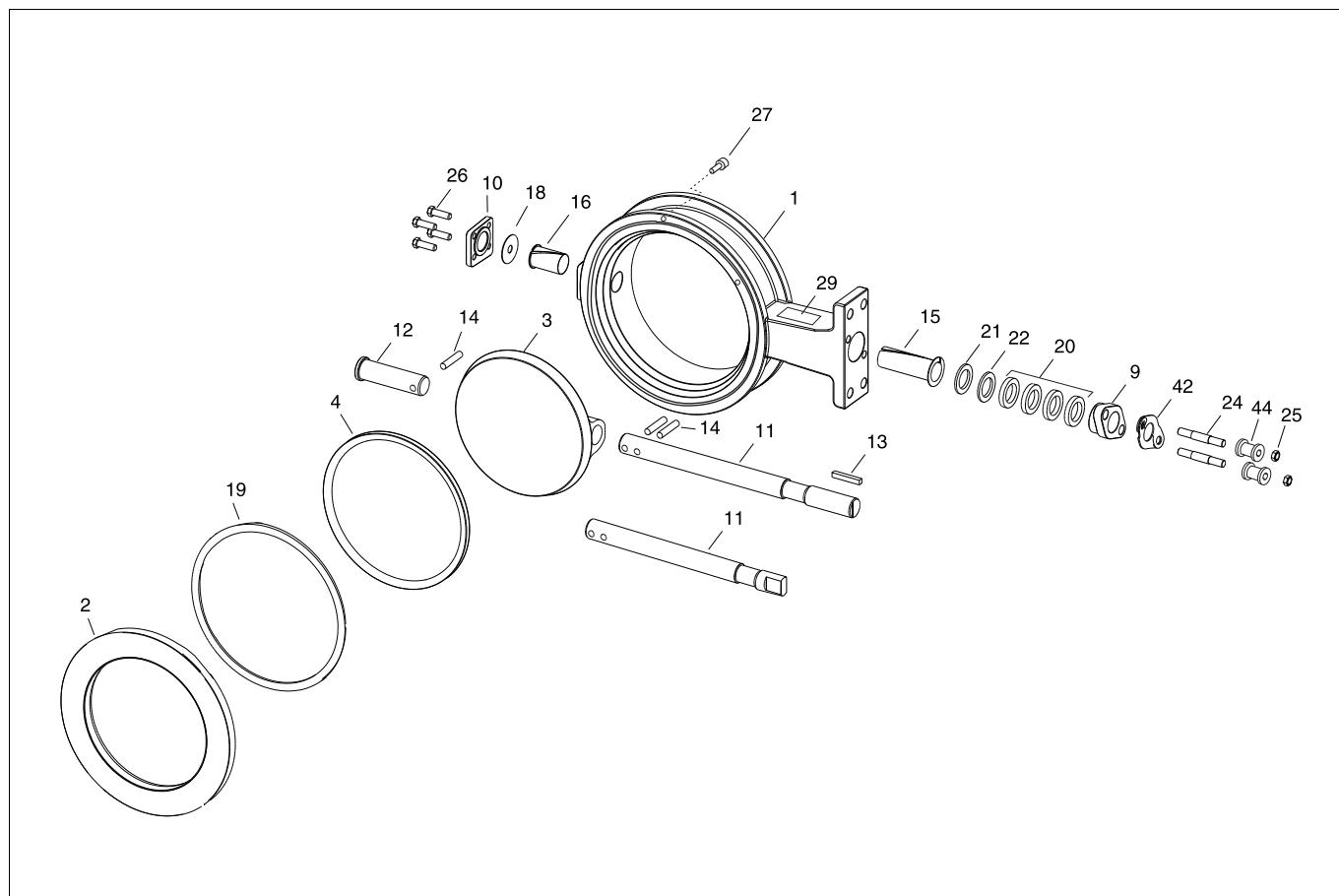

Item	Qty	Description	Recommended spare parts
1	1	Body	
2	1	Clamp ring	
3	1	Disc	
4	1	Seat ring	x
9	1	Gland	
10	1	Blind flange	
11	1	Drive shaft	
12	1	Shaft	
13	1	Key	
14	3	Pin	
15	1	Bearing	
16	1	Bearing	
18	1	Gasket	x
19	1	Body seal	x
20	1 set	Gland packing	x
21	1	Sheet ring	
22	1	Anti-extrusion ring	
24	2	Stud	
25	2	Hexagon nut	
26		Hexagon screw	
27		Hexagon socket screw	
29	1	Identification plate	
42	2	Retaining plate	
44	2	TA-Luft kit	

10 DIMENSIONS AND WEIGHTS

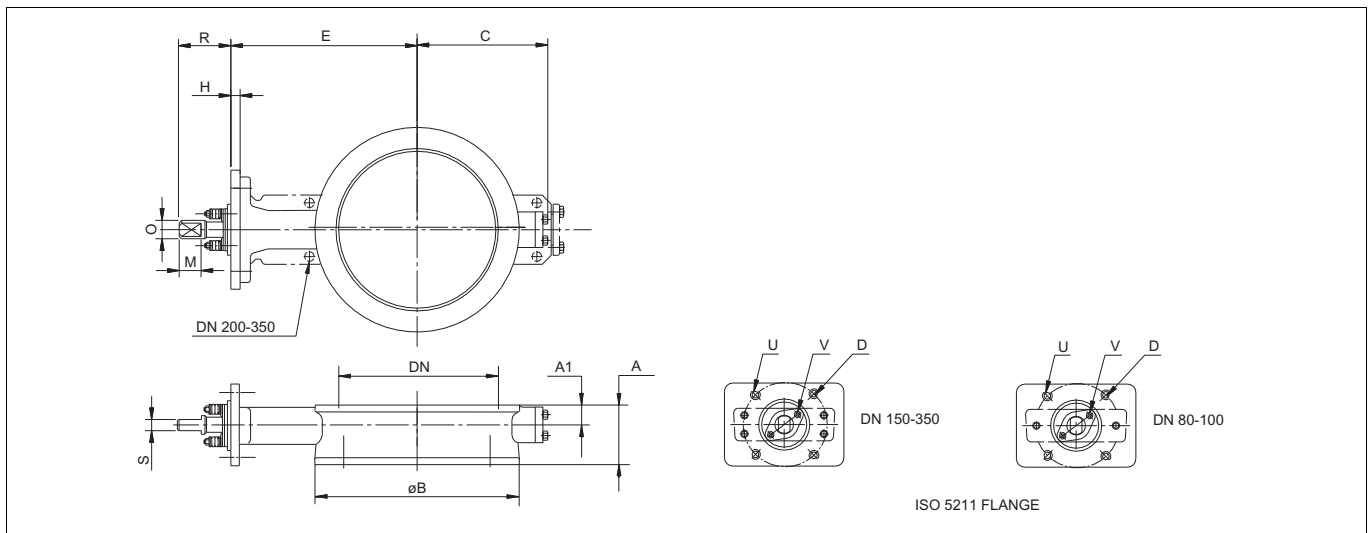

L16L, L17L/PN 25 with blade

DN	Dimensions, mm									U Thread	V Thread	Dimensions, mm				Weight kg
	A1	L16 A (K1)	L17 A (K2)	ø B	C	E	H	ISO 5211 Flange	D			O	R	M	S	
80	18	46	49	128	80	188	20	F10	102	M10	M8	14	55	11	11	4
100	20	52	56	158	100	202	20	F10	102	M10	M8	18	55	14	14	6
125	22	56	64	190	135	225	20	F10	102	M10	M8	18	55	14	14	9
150	23	56	70	212	150	247	20	F10	102	M10	M8	18	55	14	14	15
200	24	60	71	268	160	277	20	F12	125	M12	M10	22	70	17	17	20
250	29	68	76	320	210	310	20	F14	140	M16	M10	26	75	19	19	30
300	32	78	83	378	275	340	20	F14	140	M16	M10	33	80	24	24	45
350	36	78	92	438	290	385	30	F16	165	M20	M10	38	75	27	27	70

L18M/PN 50 with blade

DN	Dimensions, mm									U Thread	V Thread	Dimensions, mm				kg
	A1	A	ø B	C	E	H	ISO 5211 Flange	D	O			R	M	S		
80	18	64	128	80	188	20	F10	102	M10	M8	14	55	11	11	4	
100	20	64	158	100	202	20	F10	102	M10	M8	18	55	14	14	6	
150	28	76	218	145	252	20	F12	125	M12	M10	22	70	17	17	20	
200	35	89	278	205	294	20	F14	140	M16	M10	33	80	24	24	40	
250	56	114	335	260	350	30	F16	165	M20	M14	42	90	30	30	70	
300	53	114	395	300	390	30	F16	165	M20	M14	48	97	36	36	90	
350	62	127	450	330	430	30	F16	165	M20	M14	55	125	41	41	125	

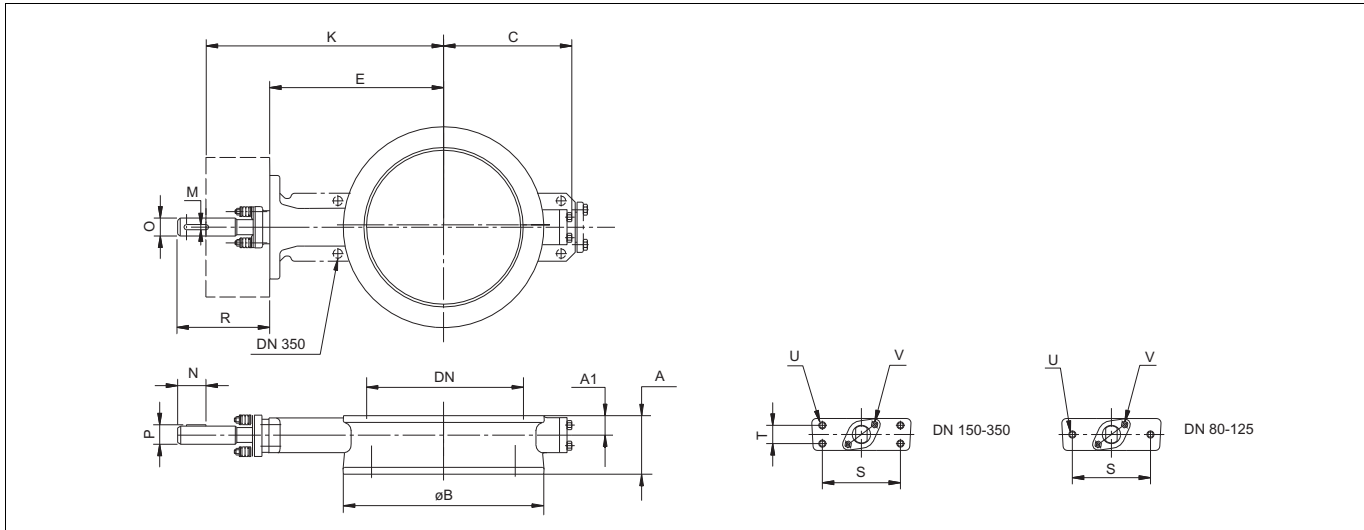
L16L, L17L/PN 25 with key way

DN	Dimensions, mm									U Thread	V Thread	Dimensions, mm					Weight kg
	A1	A (K1)	A (K2)	ø B	C	E	K	S	T			O	R	M	N	P	
80	18	46	49	128	80	168	248	70	-	M10	M8	15	105	4.76	25	17	4
100	20	52	56	158	100	182	272	90	-	M12	M8	20	125	4.76	35	22.2	6
125	22	56	64	190	135	205	295	90	-	M12	M8	20	125	4.76	35	22.2	9
150	23	56	70	212	150	227	317	110	32	M12	M8	20	125	4.76	35	22.2	15
200	24	60	71	268	160	257	347	110	32	M12	M10	25	135	6.35	46	27.8	20
250	29	68	76	320	210	290	400	130	32	M12	M10	30	160	6.35	51	32.9	30
300	32	78	83	378	275	320	430	130	32	M12	M10	35	160	9.52	58	39.1	45
350	36	78	92	438	290	355	475	160	40	M16	M10	40	188	9.52	68	44.2	70

L18M/PN 50 with key way

DN	Dimensions, mm								U Thread	V Thread	Dimensions, mm					Weight kg
	A	A (K3)	ø B	C	E	K	S	T			O	R	M	N	P	
80	18	64	128	80	168	248	70	-	M10	M8	15	105	4.76	25	17	4
100	20	64	158	100	182	272	90	-	M12	M8	20	125	4.76	35	22.2	6
150	28	76	218	145	232	322	110	32	M12	M10	25	135	6.35	46	27.8	20
200	35	89	278	205	274	364	130	32	M12	M10	35	146	9.52	58	39.1	40
250	56	114	335	260	320	440	160	40	M16	M14	45	200	12.7	80	50.4	70
300	53	114	395	300	360	500	160	55	M20	M14	50	230	12.7	90	55.5	90
350	62	127	450	330	400	540	160	55	M20	M14	55	230	12.7	90	60.6	125

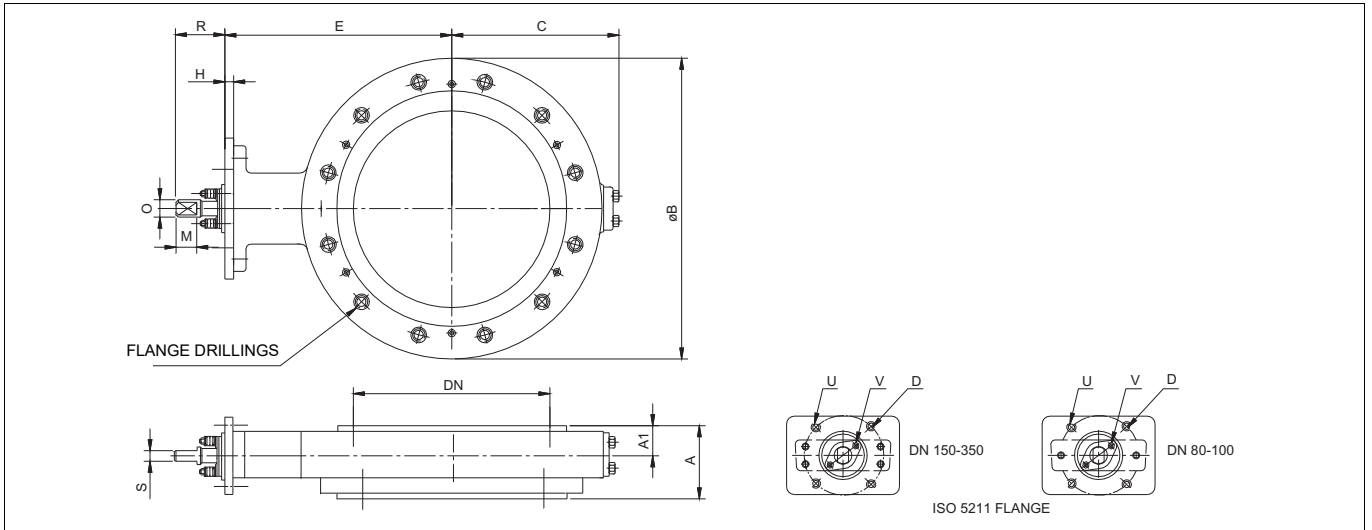

L26L, L27L/PN 25 with blade

DN	Dimensions, mm										U Thr.	V Thr.	Flange drillings								Dimensions, mm				Wt. kg
	A	A (K1)	A (K2)	ø B	C	E	H	ISO 5211 Flange	D	PN 10			PN 16		PN 25		ISO PN 20		O	R	M	S			
	Thr.	Qty	Thr.	Qty	Thr.	Qty	Thr.	Qty	Thr.	Qty			Thr.	Qty	Thr.	Qty	Thr.	Qty							
80	18	46	49	205	120	188	20	F10	102	M10	M8	M16	8	M16	8	M16	8	M16	4	14	55	11	11	10	
100	20	52	56	235	135	202	20	F10	102	M10	M8	M16	8	M16	8	M20	8	M16	8	18	55	14	14	12	
125	22	56	64	270	145	225	20	F10	102	M10	M8	M16	8	M16	8	M24	8	M20	8	18	55	14	14	20	
150	23	56	70	300	160	247	20	F10	102	M10	M8	M20	8	M20	8	M24	8	M20	8	18	55	14	14	30	
200	24	60	71	360	185	277	20	F12	125	M12	M10	M20	8	M20	12	M24	12	M20	8	22	70	17	17	50	
250	29	68	76	425	220	310	20	F14	140	M16	M10	M20	12	M24	12	M27	12	M24	12	26	75	19	19	80	
300	32	78	83	485	275	340	20	F14	160	M16	M10	M20	12	M24	12	M27	16	M24	12	33	80	24	24	110	
350	36	78	92	555	310	385	30	F16	165	M20	M10	M20	16	M24	16	M30	16	M27	12	38	75	27	27	150	

L28M/PN 50 with blade

DN	Dimensions, mm										U Thr.	V Thr.	Flange drillings								Dimensions, mm				Wt. kg
	A	A (K1)	ø B	C	E	H	ISO 5211 Flange	D	PN 25				PN 40		ISO PN 50		O	R	M	S					
	Thr.	Qty	Thr.	Qty	Thr.	Qty	Thr.	Qty	Thr.	Qty			Thr.	Qty	Thr.	Qty									
80	18	64	205	120	188	20	F10	102	M10	M8	M16	8	M16	8	M20	8	14	55	11	11	15				
100	20	64	235	135	202	20	F10	102	M10	M8	M20	8	M20	8	M20	8	18	55	14	14	20				
150	28	76	290	160	252	20	F12	125	M12	M10	M24	8	M24	8	M20	12	22	70	17	17	45				
200	35	89	365	200	294	20	F14	140	M16	M10	M24	12	M27	12	M24	12	33	80	24	24	80				
250	56	114	435	260	350	30	F16	165	M20	M14	M27	12	M30	12	M27	16	42	90	30	30	125				
300	53	114	500	296	390	30	F16	165	M20	M14	M27	16	M30	16	M30	16	48	97	36	36	180				
350	62	127	565	326	430	30	F16	165	M20	M14	M30	16	M33	16	M30	20	55	125	41	41	230				

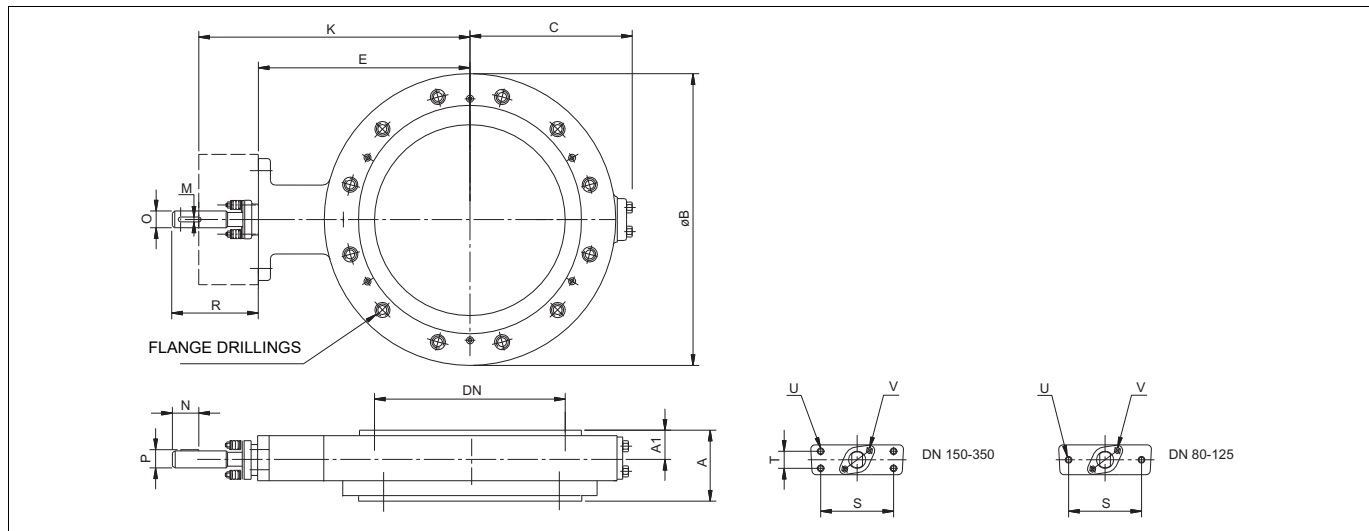

L26L, L27L/PN 25 with key way

DN	Dimensions, mm										Flange drillings								Dimensions, mm					Wt. kg	
	A	L26 A (K1)	L27 A (K2)	$\varnothing B$	C	E	K	S	T	U Thr.	V Thr.	PN 10		PN 16		PN 25		ISO PN 20		O	R	M	N		P
												Thr.	Qty	Thr.	Qty	Thr.	Qty	Thr.	Qty						
80	18	46	49	205	120	168	248	70	-	M10	M8	M16	8	M16	8	M16	8	M16	4	15	105	4.76	25	17	10
100	20	52	56	235	135	182	272	90	-	M12	M8	M16	8	M16	8	M20	8	M16	8	20	125	4.76	35	22.2	12
125	22	56	64	270	145	205	295	90	-	M12	M8	M16	8	M16	8	M24	8	M20	8	20	125	4.76	35	22.2	20
150	23	56	70	300	160	227	317	110	32	M12	M8	M20	8	M20	8	M24	8	M20	8	20	125	4.76	35	22.2	30
200	24	60	71	360	185	257	347	110	32	M12	M10	M20	8	M20	12	M24	12	M20	8	25	135	6.35	46	27.8	50
250	29	68	76	425	220	290	400	130	32	M12	M10	M20	12	M24	12	M27	12	M24	12	30	160	6.35	51	32.9	80
300	32	78	83	485	275	320	430	130	32	M12	M10	M20	12	M24	12	M27	16	M24	12	35	160	9.52	58	39.1	110
350	36	78	92	555	310	355	475	160	40	M16	M10	M20	16	M24	16	M30	16	M27	12	40	188	9.52	68	44.2	150

L28M/PN 50 with key way

DN	Dimensions, mm										Flange drillings						Dimensions, mm					kg
	A	A (K3)	$\varnothing B$	C	E	K	S	T	Thr.	Thr.	PN 25		PN 40		ISO PN 50		O	R	M	N	P	
											Thr.	Qty	Thr.	Qty	Thr.	Qty						
80	18	64	205	120	168	248	70	-	M10	M8	M16	8	M16	8	M20	8	15	105	4.76	25	17	15
100	20	64	235	135	182	272	90	-	M12	M8	M20	8	M20	8	M20	8	20	125	4.76	35	22.2	20
150	28	76	290	160	232	322	110	32	M12	M10	M24	8	M24	8	M20	12	25	135	6.35	46	27.8	45
200	35	89	365	200	274	364	130	32	M12	M10	M24	12	M27	12	M24	12	35	146	9.52	58	39.1	80
250	56	114	435	260	320	440	160	40	M16	M14	M27	12	M30	12	M27	16	45	200	12.7	80	50.4	125
300	53	114	500	296	360	500	160	55	M20	M14	M27	16	M30	16	M30	16	50	230	12.7	90	55.5	180
350	62	127	565	326	400	540	160	55	M20	M14	M30	16	M33	16	M30	20	55	230	12.7	90	60.6	230

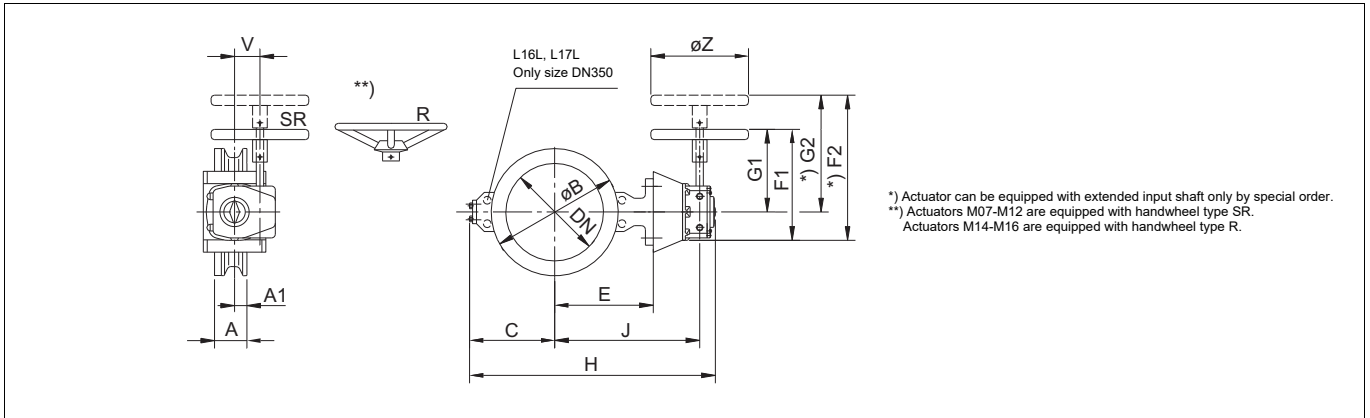

L16L, L17L + M-series

Type	DN	Actuator / Mounting ISO 5211	L16	L17	Dimensions, mm												Kg
			A (K1)	A (K2)	A1	ø B	C	E	F1	G1	*) F2	*) G2	H	J	V	ø Z	
L16L, L17L_80	80	M07/F07	46	49	18	128	80	168	196	152	-	-	390	275	39	125	8
L16L, L17L_100	100	M07/F07	52	56	20	158	100	182	196	152	-	-	435	299	39	125	10
L16L, L17L_125	125	M07/F07	56	64	22	190	135	205	196	152	-	-	495	322	39	125	13
L16L, L17L_150	150	M07/F07	56	70	23	212	150	227	196	152	-	-	530	344	39	125	19
L16L, L17L_200	200	M10/F10 or M10E/F10	60	71	24	268	160	257	227	169	297	239	580	382	52	200	26
L16L, L17L_250	250	M12/F12 or M12E/F12	68	76	29	320	210	290	285	210	357	282	695	442	67	250	42
L16L, L17L_300	300	M14/F14 or M14E/F14	78	83	32	378	275	320	378	279	453	354	805	480	90	457	66
L16L, L17L_350	350	M14/F16 or M14E/F16	78	92	36	438	290	355	378	279	453	354	865	525	90	457	94

L18M + M-series

Type	DN	Actuator / Mounting ISO 5211	L18	Dimensions, mm												Kg
			A (K3)	A1	ø B	C	E	F1	G1	*) F2	*) G2	H	J	V	ø Z	
L18M_80	80	M07/F07	64	18	128	80	168	196	152	-	-	390	275	39	125	8
L18M_100	100	M07/F07	64	20	158	100	182	196	152	-	-	435	299	39	125	10
L18M_150	150	M10/F10 or M10E/F10	76	28	218	145	232	227	169	297	239	540	357	52	200	26
L18M_200	200	M14/F14 or M14E/F14	89	35	278	205	274	378	279	453	354	670	414	90	457	60
L18M_250	250	M14/F16 or M14E/F16	114	56	335	260	320	378	279	453	354	800	490	90	457	91
L18M_300	300	M15/F16 or M15E/F16	114	53	395	300	360	457	331	532	406	910	550	123	457	125
L18M_350	350	M15/F16 or M15E/F16	127	62	450	330	400	457	331	532	406	980	590	123	457	160

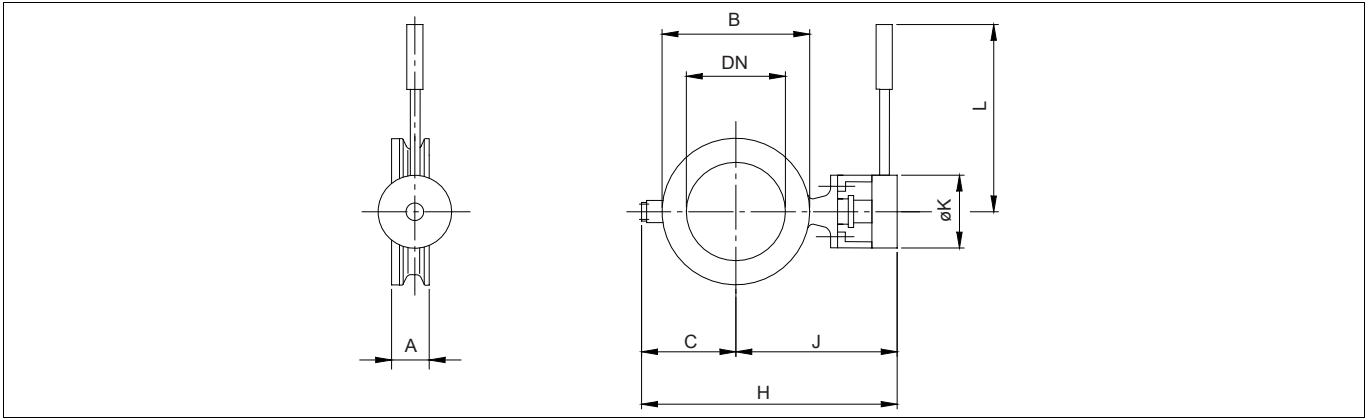
L16L, L17L + RH

Type	DN	L16	L17	Dimensions, mm								Kg
		A (K1)	A (K2)	A1	ø B	C	E	H	J	ø K	L	
L16L, L17L_80 - RH415	80	46	49	18	128	80	168	355	275	100	400	5
L16L, L17L_100 - RH420	100	52	56	20	158	100	182	410	310	100	400	8
L16L, L17L_125 - RH420	125	56	64	22	190	135	205	465	330	100	400	11
L16L, L17L_150 - RH520	150	56	70	23	212	150	227	520	370	130	500	19

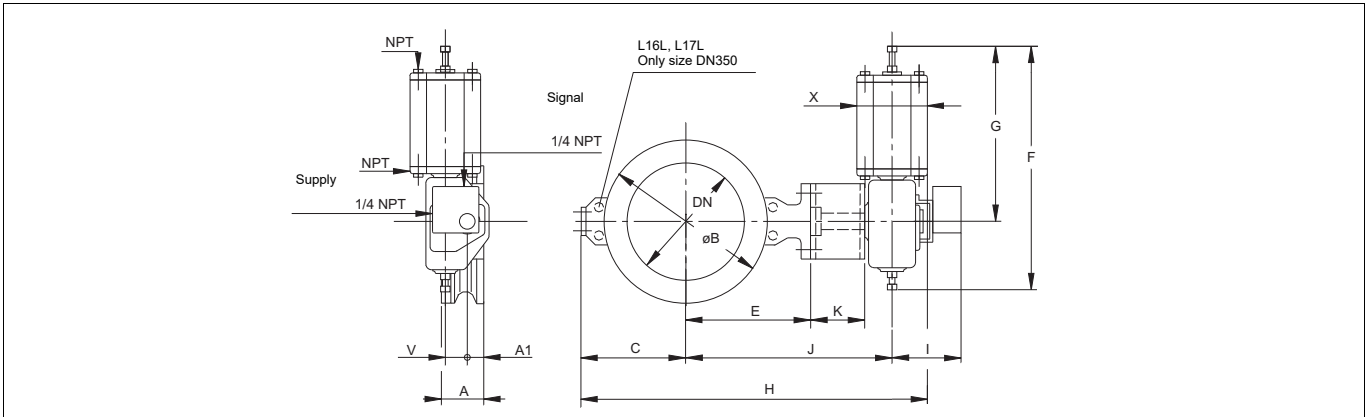

L16L, L17L + B1C

Type	DN	L16	L17	Dimensions, mm													NPT	Kg
		A (K1)	A (K2)	A1	øB	C	E	F	G	H	X	I	J	V	K			
L16L, L17L_80-B1C9	80	49	49	18	128	80	168	455	315	445	110	220	307	43	80	1/4	22	
L16L, L17L_100-B1C9	100	52	56	20	158	100	182	455	315	490	110	220	331	43	90	1/4	24	
L16L, L17L_100-B1C11	100	52	56	20	158	100	182	540	375	510	135	225	337	51	90	3/8	30	
L16L, L17L_125-B1C9	125	56	64	22	190	135	205	455	315	550	110	220	354	43	90	1/4	26	
L16L, L17L_125-B1C11	125	56	64	22	190	135	205	540	375	570	135	225	360	51	90	3/8	33	
L16L, L17L_150-B1C9	150	56	70	23	212	150	227	455	315	585	110	220	376	43	90	1/4	33	
L16L, L17L_150-B1C11	150	56	70	23	212	150	227	540	375	605	135	225	382	51	90	3/8	39	
L16L, L17L_150-B1C13	150	56	70	23	212	150	227	635	445	640	175	240	398	65	90	3/8	57	
L16L, L17L_200-B1C11	200	60	71	24	268	160	257	540	375	645	135	225	412	51	90	3/8	44	
L16L, L17L_200-B1C13	200	60	71	24	268	160	257	635	445	680	175	240	428	65	90	3/8	62	
L16L, L17L_200-B1C17	200	60	71	24	268	160	257	770	545	715	215	255	443	78	90	1/2	85	
L16L, L17L_250-B1C13	250	68	76	29	320	210	290	635	445	785	175	240	481	65	110	3/8	74	
L16L, L17L_250-B1C17	250	68	76	29	320	210	290	770	545	820	215	255	496	78	110	1/2	100	
L16L, L17L_300-B1C13	300	78	83	32	378	275	320	635	445	880	175	240	511	65	110	3/8	89	
L16L, L17L_300-B1C17	300	78	83	32	378	275	320	770	545	915	215	255	526	78	110	1/2	115	
L16L, L17L_300-B1C20	300	78	83	32	378	275	320	840	575	935	215	270	545	97	110	1/2	135	
L16L, L17L_350-B1C17	350	78	92	36	438	290	355	770	545	975	215	255	571	78	120	1/2	155	
L16L, L17L_350-B1C20	350	78	92	36	438	290	355	840	575	995	215	270	590	97	120	1/2	175	
L16L, L17L_350-B1C25	350	78	92	36	438	290	355	1040	710	1040	265	310	613	121	120	1/2	240	

L18M + B1C

Type	DN	L18	Dimensions, mm													NPT	Kg
		A (K3)	A1	øB	C	E	F	G	H	X	I	J	V	K			
L18M_80-B1C9	80	64	18	128	80	168	455	315	445	110	220	307	43	80	1/4	22	
L18M_100-B1C9	100	64	20	158	100	182	455	315	490	110	220	331	43	90	1/4	24	
L18M_100-B1C11	100	64	20	158	100	182	540	375	510	135	225	337	51	90	3/8	30	
L18M_150-B1C9	150	76	28	218	145	232	540	375	605	135	225	387	51	90	3/8	44	
L18M_150-B1C11	150	76	28	218	145	232	635	445	640	175	240	403	65	90	3/8	62	
L18M_150-B1C13	150	76	28	218	145	232	770	545	675	215	255	418	78	90	1/2	87	
L18M_200-B1C11	200	89	35	278	205	274	635	445	745	175	240	445	65	90	3/8	84	
L18M_200-B1C13	200	89	35	278	205	274	770	545	780	215	255	460	78	90	1/2	110	
L18M_200-B1C17	200	89	35	278	205	274	840	575	795	215	270	479	78	90	1/2	130	
L18M_250-B1C17	250	114	56	335	260	320	770	545	910	215	255	536	78	120	1/2	155	
L18M_250-B1C20	250	114	56	335	260	320	840	575	930	215	270	555	97	120	1/2	170	
L18M_250-B1C25	250	114	56	335	260	320	1040	710	975	265	310	578	121	120	1/2	230	
L18M_300-B1C20	300	114	53	395	300	360	840	575	1030	215	270	615	97	140	1/2	200	
L18M_300-B1C25	300	114	53	395	300	360	1040	710	1075	265	310	638	121	140	1/2	260	
L18M_350-B1C20	350	127	62	450	330	400	840	575	1100	215	270	655	97	140	1/2	240	
L18M_350-B1C25	350	127	62	450	330	400	1040	710	1145	265	310	678	121	140	1/2	295	

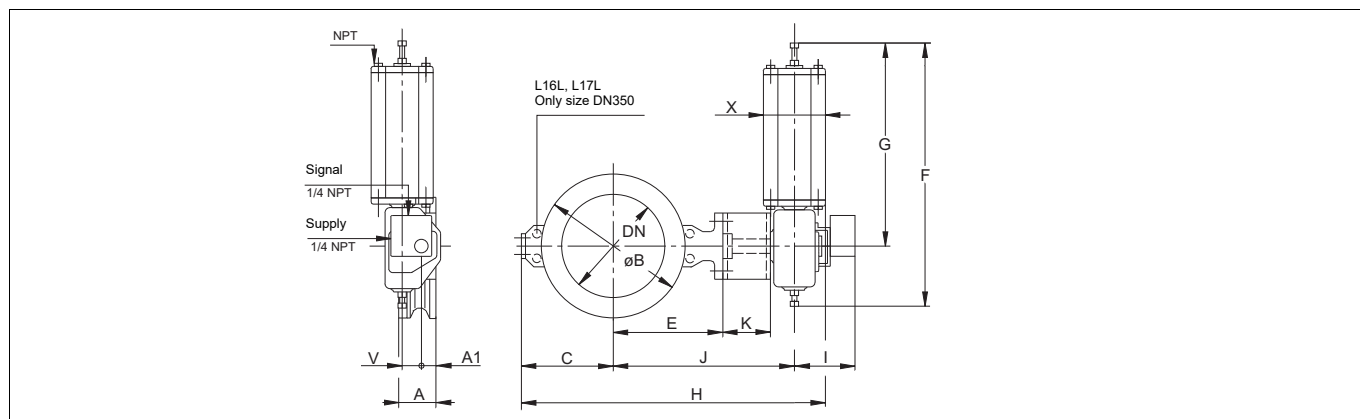

L16L, L17L + B1J/B1JA

Type	DN	L16	L17	Dimensions in mm												NPT	Kg
		A (K1)	A (K2)	A1	ø B	C	E	F	G	H	X	I	J	V	K		
L16L, L17L_80-B1J8	80	49	49	18	128	80	168	560	420	460	135	220	307	43	80	3/8	29
L16L, L17L_100-B1J8	100	52	56	20	158	100	182	560	420	505	135	220	331	43	90	3/8	31
L16L, L17L_100-B1J10	100	52	56	20	158	100	182	650	490	530	175	225	337	51	90	3/8	44
L16L, L17L_125-B1J8	125	56	64	22	190	135	205	560	420	560	135	220	354	43	90	3/8	34
L16L, L17L_125-B1J10	125	56	64	22	190	135	205	650	490	585	175	225	360	51	90	3/8	47
L16L, L17L_150-B1J8	150	56	70	23	212	150	227	560	420	600	135	220	376	43	90	3/8	40
L16L, L17L_150-B1J10	150	56	70	23	212	150	227	650	490	625	175	225	382	51	90	3/8	53
L16L, L17L_150-B1J12	150	56	70	23	212	150	227	800	620	660	215	240	398	65	90	1/2	83
L16L, L17L_200-B1J10	200	60	71	24	268	160	257	650	490	665	175	225	412	51	90	3/8	58
L16L, L17L_200-B1J12	200	60	71	24	268	160	257	800	620	700	215	240	428	65	90	1/2	88
L16L, L17L_200-B1J16	200	60	71	24	268	160	257	990	760	740	265	255	443	78	90	1/2	135
L16L, L17L_250-B1J12	250	68	76	29	320	210	290	800	620	805	215	240	481	65	110	1/2	100
L16L, L17L_250-B1J16	250	68	76	29	320	210	290	990	760	845	265	255	496	78	110	1/2	145
L16L, L17L_300-B1J12	300	78	83	32	378	275	320	800	620	900	215	240	511	65	110	1/2	120
L16L, L17L_300-B1J16	300	78	83	32	378	275	320	990	760	940	265	255	526	78	110	1/2	160
L16L, L17L_300-B1J20	300	78	83	32	378	275	320	1200	935	1025	395	270	545	97	110	3/4	235
L16L, L17L_350-B1J16	350	78	92	36	438	290	355	990	760	1000	265	255	571	78	120	1/2	200
L16L, L17L_350-B1J20	350	78	92	36	438	290	355	1200	935	1085	395	270	590	97	120	3/4	275
L16L, L17L_350-B1J25	350	78	92	36	438	290	355	1530	1200	1160	505	310	613	121	120	3/4	460

L18M + B1J/B1JA

Type	DN	L18	Dimensions, mm												NPT	Kg
		A (K3)	A1	ø B	C	E	F	G	H	X	I	J	V	K		
L18M_80-B1J8	80	64	18	128	80	168	560	420	460	135	220	307	43	80	3/8	29
L18M_100-B1J8	100	64	20	158	100	182	560	420	505	135	220	331	43	90	3/8	31
L18M_100-B1J10	100	64	20	158	100	182	650	490	530	175	225	337	51	90	3/8	44
L18M_150-B1J10	150	76	28	218	145	232	650	490	625	175	225	387	51	90	3/8	58
L18M_150-B1J12	150	76	28	218	145	232	800	620	660	215	240	403	65	90	1/2	88
L18M_150-B1J16	150	76	28	218	145	232	990	760	700	265	255	418	78	90	1/2	135
L18M_200-B1J12	200	89	35	278	205	274	800	620	765	215	240	445	65	90	1/2	112
L18M_200-B1J16	200	89	35	278	205	274	990	760	805	265	255	460	78	90	1/2	155
L18M_200-B1J20	200	89	35	278	205	274	1200	935	890	395	270	479	97	90	3/4	230
L18M_250-B1J16	250	114	56	335	260	320	990	760	935	265	255	536	78	120	1/2	200
L18M_250-B1J20	250	114	56	335	260	320	1200	935	1020	395	270	555	97	120	3/4	275
L18M_250-B1J25	250	114	56	335	260	320	1530	1200	1095	505	310	578	121	120	3/4	460
L18M_300-B1J20	300	114	53	395	300	360	1200	935	1120	395	270	615	97	140	3/4	305
L18M_300-B1J25	300	114	53	395	300	360	1530	1200	1195	505	310	638	121	140	3/4	480
L18M_350-B1J20	350	127	62	450	330	400	1200	935	1190	395	270	655	97	140	3/4	340
L18M_350-B1J25	350	127	62	450	330	400	1530	1200	1265	505	310	678	121	140	3/4	515

11 TYPE CODE

Neles™ Neldisc™ metal seated butterfly valves. Series L16, L17, L18, L26, L27, L28

1.	2.	3.	4.	5.	6.	7.	8.	9.	10.	11.	/	12.	13.
	L16	L	B	A	200	K	A	B	A	T		02	K

1.	S-DISC CONSTRUCTION
S-	Flow balancing trim on down stream side of body flow port

6.	SIZE
	080, 100, 125 (only body DIN PN 25), 150, 200, 250, 300, 350

2.	PRODUCT SERIES / DESIGN
L16	Wafer type / full bore / standard face to face: EN 558-part 1, table 5 / basic series 20, (DIN 3202-K1) body DIN PN 25
L17	Wafer type / full bore / optional face to face: EN 558-part 1, table 5 / basic series 25, (DIN 3202-K2) body DIN PN 25
L18	Wafer type / full bore / standard face to face: EN 558-part 1, table 5 / basic series 16, (DIN 3202-K3) body ISO PN 50
L26	Lug type / full bore / standard face to face: EN 558-part 1, table 5 / basic series 20, (DIN 3202-K1) body DIN PN 25
L27	Lug type / full bore / optional face to face: EN 558-part 1, table 5 / basic series 25, (DIN 3202-K2) body DIN PN 25
L28	Lug type / full bore / standard face to face: EN 558-part 1, table 5 / basic series 16, (DIN 3202-K3) body ISO PN 50

MATERIALS					
7.	BODY	8.	DISC	9.	SHAFT & PINS
K	1.4408, 1.4436 lug body only	A	F316	B	1.4418
R	1.0619, 1.0425 lug body only				

3.	PRESSURE RATING
L	Body DIN PN 25, sizes DN 080 - DN 150 full rated acc. to DIN PN 25 and sizes DN 200 - DN 350 full rated acc.to ISO PN 20
M	Body ISO PN 50, DIN PN 40, full rated

NON-STANDARD					
7.	BODY	8.	DISC	9.	SHAFT & PINS
B	1.4581	G	1.4581	N	Nitronic 50
		K	1.4401 or 1.4408		
		B	F 316 + cobalt based alloy		

4.	VALVE- ACTUATOR CONNECTION
B	Drive shaft with key way / ISO 5211 connection
E	Drive shaft with blade / ISO 5211 / NAMUR connection

10.	STANDARD SEAT	10.	NON-STANDARD SEAT
A	Incoloy 825, hard chrome plated	H	Nimonic 80A, hard chrome plated
		K	2.4681, UNS R31233 (ULTIMET)

5.	CONSTRUCTION
A	STANDARD, temperature range -50 °C...+260 °C - bearings AISI 316 + PTFE - body and blind flange gaskets graphite - live loaded TA-Luft packing with virgin PTFE V-ring - live loaded TA-Luft packing with graphite, fire-safe
C	CRYOGENIC, t_{min} -196 °C - extended bonnet and drive shaft - soft seals graphite - otherwise as construction A
N	HIGH TEMPERATURE DESIGN t_{max} +400 °C - shaft bearing surfaces coated - bearings cobalt based alloy - soft seals graphite - live loaded TA-Luft packing with graphite, fire-safe
H	HIGH TEMPERATURE DESIGN t_{max} +550 °C - shaft bearing surfaces coated - bearings cobalt based alloy - soft seals graphite - live loaded TA-Luft packing with graphite, fire-safe

11.	SPECIAL DESIGN
T	Live loaded PTFE V-ring packing with spring sets; TA-Luft tested and certified by TÜV
G	Live loaded graphite packing with disc spring sets; TA-Luft tested and certified by TÜV

12.	FLANGE FACING
02	DIN 2526 Form C (Ra 10-40), standard
03	DIN 2526 Form D (Ra 10)
04	DIN 2526 Form E (Ra 4)
07	DIN 2512 Form N (groove) (Ra 10)

13.	FLANGE DRILLING*
J	DIN PN 10
K	DIN PN 16
L	DIN PN 25
M	DIN PN 40
X	ISO PN 20
Z	ISO PN 50

Gland packing shall be specified with 11th sign.

Valmet Flow Control Oy

Vanha Porvoontie 229, 01380 Vantaa, Finland.

Tel. +358 10 417 5000.

www.valmet.com/flowcontrol

Subject to change without prior notice.

Neles, Neles Easyflow, Jamesbury, Stonel, Valvcon and Flowrox, and certain other trademarks, are either registered trademarks or trademarks of Valmet Oyj or its subsidiaries in the United States and/or in other countries.

For more information www.neles.com/trademarks

