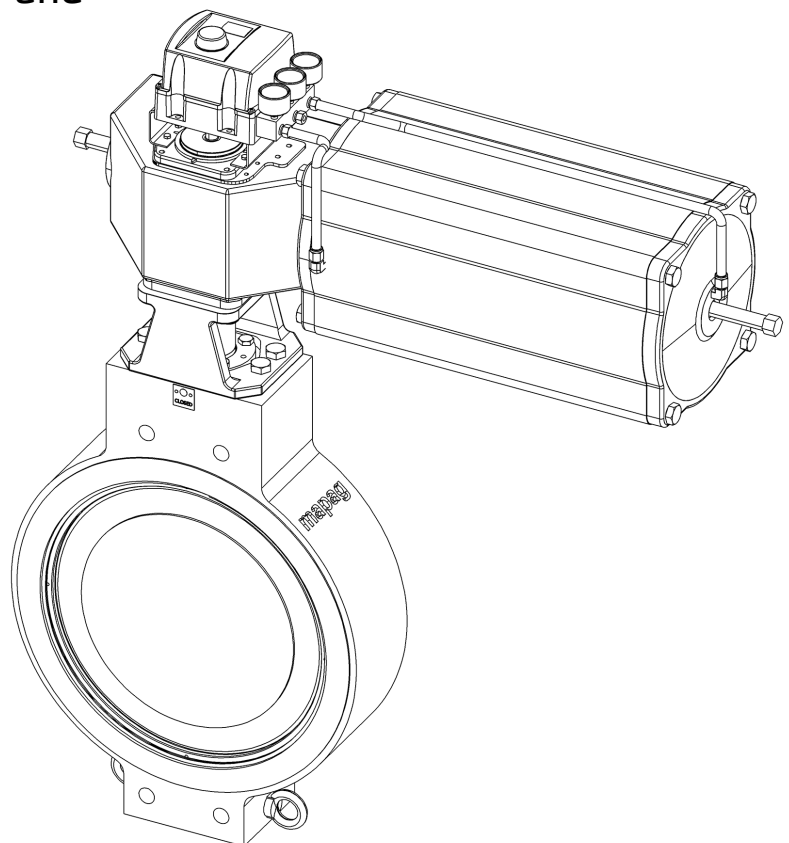


Neles™ double-eccentric butterfly valve

Series BN

Installation, maintenance and
operating instructions



CONTENTS

General information	3	Exploded view & BOM	15
Safety precautions	3	Weights and dimensions	17
Product & function description	3	Troubleshooting	20
Intended use	3	Safety instructions	20
Scope of delivery	4	Welding notes	20
Visual inspection	4	Maintenance	21
Marking and identification	4	Cleaning and maintenance	21
ATEX and CE marking	5	Preparation	21
Contact information	5	Dismounting	21
Transport, taking delivery and storage	5	Reinstallation	22
Installation	5	Replacing the sealing element	22
Planning the installation	5	Maximum permissible closing torque for valves	
Preparation	5	without actuator at 0 bar	26
Installation	6	Replacing worn parts	27
ATEX version	9	Valve screws – clamping torque	29
Dismounting the valve	9	Type code	30
Cleaning and maintenance intervals	10		
Tools	10		
Ordering spare parts	10		
Fitting and dismounting type A/F and B1C actuators	12		
General information	12		
Mounting preparations	12		
Mounting a type A/F actuator	12		
Dismounting preparation	13		
Dismounting type A/F	13		
Mounting a B1C type actuator to the valve	13		
Detaching the actuator from the valve	14		

READ THESE INSTRUCTIONS FIRST!

These instructions provide information about safe handling and operation of the valve.

If you require additional assistance, please contact the manufacturer or manufacturer's representative.

SAVE THESE INSTRUCTIONS!

Addresses and phone numbers are printed on the back cover.

1 General information

1.1 Safety precautions

CAUTION:

Do not exceed the valve performance limitations!

Exceeding the limitations marked on the valve may cause damage and lead to uncontrolled pressure release.

Damage or personal injury may result.

CAUTION:

Do not dismantle the valve or remove it from the pipeline while the valve is pressurised!

Dismantling or removing a pressurised valve will result in uncontrolled pressure release. Always isolate the relevant part of the pipeline, release the pressure from the valve and remove the medium before dismantling the valve. Be aware of the type of medium involved. Protect people and the environment from any harmful or poisonous substances. Ensure that no medium can enter the pipeline during valve maintenance.

Failure to do this may result in damage or personal injury.

CAUTION:

Beware of the disc's cutting movement!

Keep hands, other parts of the body, tools and other objects out of the open flow port. Leave no foreign objects inside the pipeline. When the valve is actuated, the disc behaves like a cutting device. The position of the disc can also be changed when moving the valve.

Close and detach the actuator pressure supply pipeline for valve maintenance.

Failure to do this may result in damage or personal injury.

CAUTION:

Beware of noise emissions!

The valve may produce noise in the pipeline. The noise level depends on the application. It can be measured or calculated using Neles Nelprof valve-sizing software.

Observe the relevant work environment regulations on noise emissions.

CAUTION:

When handling the valve or the valve package, bear in mind its weight!

Never lift the valve or valve package by the actuator, positioner, limit switch or their piping.

Valve sizes DN 400 and over are equipped with lifting eye bolts.

Place the lifting ropes securely around the valve body.

Damage or personal injury may result from falling parts.

Caution when lifting, the disc may turn.

1.2 Product & function description

BN series double eccentric butterfly valve, elastomer sealing elements, closing tight in both directions. BN series eccentric butterfly valve, thermoplastic sealing elements, closing tight in one direction.

Type of body:

- Type BN3** Flange
- Type BN4** Mono flange
- Type BN6** Wafer

Nominal size:

- DN 80, 100, 150, 200, 250, 300, 350, 400, 500, 600, 700, 800, 900, 1000, 1200, 1400, 1600
- NPS 3, 4, 6, 8, 10, 12, 14, 16, 20, 24, 28, 32, 36, 40, 48, 56, 64

Pressure rating:

- PN 10, 16, 25, 40, 63, 100
- CLASS 150, 300, 600

Temperature range:

- Operating temperature -29 °C to +200 °C
- Storage temperature -20 °C to +80 °C

Function description:

Neles BN series butterfly valves are used for shutting off pipelines and controlling product streams. Each butterfly valve is designed according to customer requirements.

The BN series butterfly valves are manufactured using a modular system and spare parts are generally available at short notice, modifying the valves for higher tightness in relation to the operating environment is possible.

Construction:

The shaft has a triple bearing. Operation of the butterfly valve is not compromised in any way even at a differential pressure (ΔP) of up to 10 bars.

The BN series butterfly valves are equipped with an elastic sealing element. Depending on the specifications for the valve, this sealing element is made either from an elastomer or from thermoplastic.

- Elastomer seals shut bubble tight on both sides. They can be used at temperatures between -10 and +200 °C depending on the medium.
- Thermoplastic seals can be used at temperatures between -40 and +250 °C. They are particularly chemically resistant and shut bubble tight on one side.

Please refer to your order-specific documentation for the exact operating range of your BN series butterfly valve.

In order to ensure the longevity of the sealing element, the disc is mounted double eccentrically. It shuts almost completely without friction.

1.3 Intended use

The supplied valve has been specially designed according to the requirements as outlined in the order-specific documentation. This applies in particular to the operating parameters pressure, temperature and medium. If a wrong medium, a higher pressure or higher or lower temperatures are used in the pipelines by mistake, the entire valve may be damaged. Defective parts must be replaced immediately.

The pipelines and the medium used must be free of dirt at all times. Otherwise the tightness of the valve may be adversely affected.

In order to ensure correct operation, operators, fitters and maintenance personnel must have read and understood this operating manual.

Only qualified personnel may perform the installation work.

Valmet does not assume liability for any structural modifications that have been carried out without the explicit consent of Valmet.

Please use original spare parts only.

Those should be fitted by Valmet service personnel.

1.4 Scope of delivery

The valve is supplied in one of three possible versions: flange, wafer or lug (mono flange).

The valve is usually supplied complete with actuator.

1.5 Visual inspection

Valve tightness and functionality were checked by the quality assurance team before leaving the Valmet plant and the valve has been calibrated for operation according to the order-specific documentation.

Please check the valve for possible transport damage before installation. Please notify our service personnel immediately should any of the supplied parts be damaged.

Please check the valve's functions before it is installed. Proceed as follows:

- Depending on size and weight of the valve you will need lifting ropes.

Always attach the ropes to the housing if the valve is transported in a horizontal position (see fig. 1). The shaft may be damaged if the ropes are attached to the actuator.

Caution: Danger of twisting!



Fig. 1 Rope position on the valve

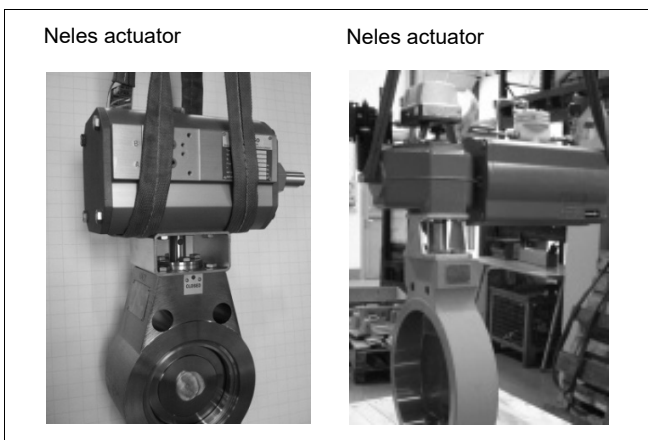


Fig. 2 Rope position on the actuator

- Visual inspection – all screws must be tightened correctly
 - Visual inspection for damage to the following parts:
 - Disc
 - Shaft
 - Actuator and tubing

- Gland packing
- Sealing element
- Sealing surfaces of the valve
- Bring the valve into a vertical position.

During the function test the valve might move in an uncontrolled fashion. There fore please ensure that the valve cannot move or even tilt, under any circumstances, during the function test.



- Now connect the energy supply. Ensure that the actuator opens in the correct direction of flow.

Generally:

Top view of the valve's driveshaft:

Counter-clockwise rotation = opening

Clockwise rotation = closing

(see fig. 4).

(This might change for specific orders.)

- Test if the valve functions correctly. Open and shut the valve several times. The actuator's end stop ensures that the disc cannot be turned further than into the "shut" position as calibrated in the factory.
- Disconnect the energy supply after testing.

Please contact our service team should the valve not operate correctly during the function test.

The following symptoms could indicate problems:

- The disc does not move at all, moves too slowly or does not move evenly
- The valve makes unusual running noises
- The disc does not move fully into position
- The disc does not completely open

1.6 Marking and identification



Fig. 3 Example of identification plate

The identification plate with the valve specifications is located on the valve body.

The unique ID number is needed to identify the valve for service calls. This number is also engraved on the valve body in case the identification plate cannot be located.

Further information:

Valmet	=	Valmet job number Valmet Flow Control GmbH
ID number	=	The unique ID number
Type	=	Valve type code
Body	=	Body material
Year	=	Year of manufacture
NPS or DN	=	Size
CL or PN	=	Pressure class
ID-No.	=	Customer identification number

Tag-No.	=	Valve Tag-number
TS	=	Valve operating temperature range in °C (medium)
PS	=	Valve max. design pressure at max. temp.
P.O.NO.	=	Customer order number / commission number
CV	=	Flow rate in gal / min
EX II 2G C Tx=	=	ATEX-marking
CE	=	CE0036 (notified body für PED)

To indicate the disc position when the valve is fitted, the following markings are provided (see fig. 4):

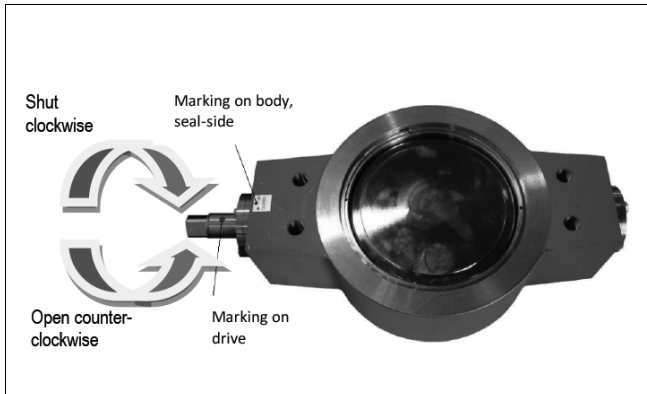


Fig. 4 Direction of shaft rotation and disc position

- SIGN CLOSED with coloured marking on body.
- Coloured marking on valve shaft.

When those two red markings are aligned, the disc is in the CLOSED position. The sealing element is located on the side of the body where the SIGN CLOSED is attached.

1.7 ATEX and CE marking

The valve meets the requirements set out in the European Pressure Equipment Directive 2014/68/EU and has been marked in accordance with this directive.

The ATEX and CE markings are located on the identification plate (see fig. 3, identification plate).

1.8 Contact information

Please contact your local Valmet partner. You can find contact details on: www.neles.com/valves

2 Transport, taking delivery and storage

Check the valve and all accessories for transport damage.
 Store the valve carefully indoors, in a dry area, before it is fitted.
 Storage temperature = -20... 80 °C Humidity 85% max. (non-condensing)
 The valve must be stored with the factory-fitted flow port protectors in place.
 The valve should only be transported to the operating area just before it is installed.
 The flow port protectors must be removed before the valve is fitted.
 The valve is supplied in the "closed" position.
 Valves equipped with spring-return actuators are supplied in the position determined by the spring (spring opens or spring closes).

3 Installation

Installation work on the valve may only be carried out by qualified personnel!



3.1 Planning the installation

Consider the following aspects before installing the valve:

- Ensure that you will have easy access to the actuator at all times when the valve is in place.
- For actuators that are operated by electrical, pneumatic or hydraulic energy, the energy supply must be connected after installation of the valve.
- The flange holes of both pipe ends must be exactly aligned, the sealing surfaces of the opposing flanges must be exactly parallel. The flange holes must not be twisted against each other in order to ensure that the installation does not cause stress to the valve.

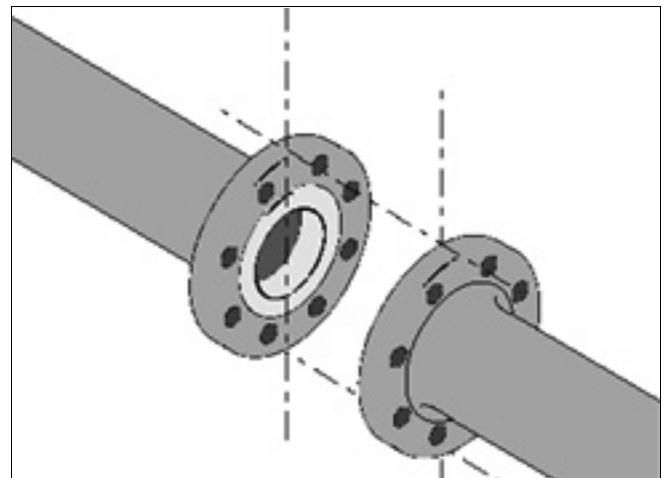


Fig. 5 Alignment of flanges

3.2 Preparation

Before fitting the valve, make sure that the pipes and flanges are completely free of dirt. Any impurities, such as welding residues, rust or dirt, may affect the valve's tightness and damage the sealing surface of the disc or the sealing elements. This applies especially when valves are installed in new sections of the system. It must also be ensured that the medium does not carry any contaminants that may settle in the sealing area.

Caution is advised when installing valves with safety position "spring-to-open"



If the disc protrudes from the valve in open position, the valve must be closed before installation (pneumatically, hydraulically etc.). Ensure that the energy supply is securely fastened and cannot be damaged or severed during installation under any circumstances.

If the energy supply is interrupted suddenly, the pre-stressed set of springs will open the valve abruptly. This may cause severe injuries and material damage.

For installing larger valves a hoist is required to lift the valve into position. The total weight of valve and actuator can be found in the order-specific documentation.

Always attach the lifting ropes to the valve body, never to the actuator or any parts or pipes belonging to it!



3.3 Installation

Install the valve as follows:

- Turn the valve in such a way that the arrow (P for pressure) on the body points in the process' direction of pressure (see fig. 6, direction of pressure).



Fig. 6 Direction of pressure

- Close the valve for installation. In the open position the sealing surface of the disc may protrude from the body and could be damaged during installation.
- Install the valve in the pipeline so that the shaft is horizontal or across horizontal. However, we do not recommend installing the valve with the actuator on the underside because valve will be damaged.
- Please note the minimum inside diameter of the pipe according to ASME B36.10M, ASME B36.19M or DIN EN 10305-2 and DIN EN 10305-5.
- Insert a flange gasket on both sides of the valve between the valve body and the flanges facing it. These two gaskets are not included in the standard scope of delivery. We can supply the required gaskets on request.
- For installation, refer to the bolt sizes listed in tables 1 – 12.

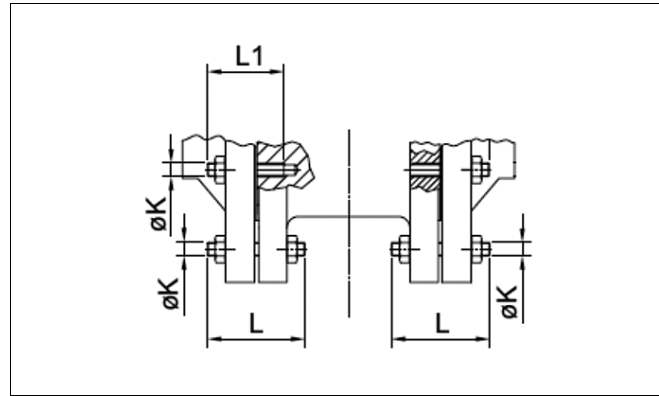


Fig. 7 Type BN3, BN4

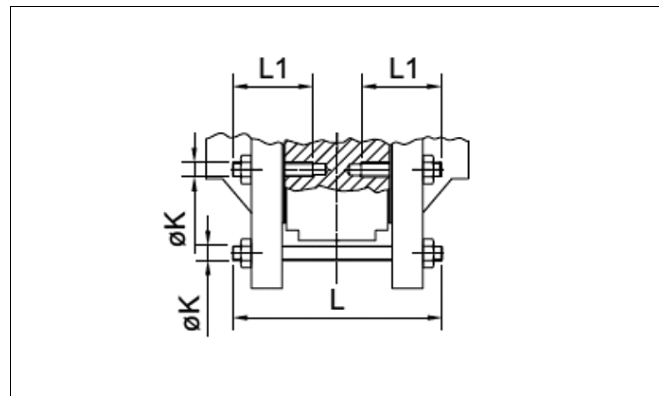


Fig. 8 Type BN6

Stud bolt dimensions ASME B16.47 / DIN EN 1092-1

Table 1-6 Stud bolts

Stud bolts BN3C - (double flange) up to 24 ASME B16.5 (Cl 150) 24"-56" ASME B16.47 Serie B (Cl 150)			
NPS	Thread K	L	
		Length	Quantity
3	5/8"-10UNC	100	8
4	5/8"-10UNC	100	16
6	3/4"-10UNC	110	16
8	3/4"-10UNC	120	16
10	7/8"-9UNC	130	24
12	7/8"-9UNC	135	24
14	1"-8UN	150	24
16	1"-8UN	155	32
20	1 1/8"-8UN	170	40
24	1 1/4"-8UN	195	40
28	3/4"-10UNC	150	80
32	3/4"-10UNC	150	96
36	7/8"-9UNC	175	88
40	1"-8UN	190	88
48	1 1/8"-8UN	215	88
56	1 1/8"-8UN	230	120

Stud bolts BN4C - (mono flange) up to 2" ASME B16.5 (Cl 150) 24"-56" ASME B16.47 Serie B (Cl 150)			
NPS	Thread K	L	
		Länge	Quantity
3	5/8"-10UNC	75	8
4	5/8"-10UNC	75	16
6	3/4"-10UNC	85	16
8	3/4"-10UNC	85	16
10	7/8"-9UNC	95	24
12	7/8"-9UNC	100	24
14	1"-8UN	110	24
16	1"-8UN	110	32
20	1 1/8"-8UN	125	40
24	1 1/4"-8UN	140	40
28	3/4"-10UNC	100	80
32	3/4"-10UNC	105	96
36	7/8"-9UNC	120	88
40	1"-8UN	130	88
48	1 1/8"-8UN	145	88
56	1 1/8"-8UN	155	120

Stud bolts BN6C - (wafer) up to 24" ASME B16.5 (Cl 150) 24"-56" ASME B16.47 Serie B (Cl 150)					
NPS	Thread K	L		L1	
		Length	Quantity	Length	Quantity
3	5/8"-10UNC	165	-	75	8
4	5/8"-10UNC	165	4	75	8
6	3/4"-10UNC	190	4	85	8
8	3/4"-10UNC	210	4	85	8
10	7/8"-9UNC	250	8	95	8
12	7/8"-9UNC	250	8	100	8
14	1"-8UN	280	8	110	8
16	1"-8UN	300	12	110	8
20	1 1/8"-8UN	325	16	125	8
24	1 1/4"-8UN	375	16	140	8
28	3/4"-10UNC	380	36	100	8
32	3/4"-10UNC	395	44	105	8
36	7/8"-9UNC	420	40	120	8
40	1"-8UN	495	36	130	16
48	1 1/8"-8UN	570	36	145	16
56	1 1/8"-8UN	625	52	155	16

Stud bolts BN3J - (double flange) EN 1092-1 (PN 10)			
DN	ThreadK	L	
		Length	Quantity
80	M16	95	8
100	M16	95	8
150	M20	110	8
200	M20	115	8
250	M20	120	12
300	M20	120	12
350	M20	120	16
400	M24	130	16
500	M24	135	20
600	M27	150	20
700	M27	160	24
800	M30	170	24
900	M30	170	28
1000	M33	195	28
1200	M36	220	32
1400	M39	250	36

Stud bolts BN4J - (mono flange) EN 1092-1 (PN 10)			
DN	Thread K	L	
		Länge	Quantity
80	M16	70	8
100	M16	70	8
150	M20	80	8
200	M20	85	8
250	M20	85	12
300	M20	85	12
350	M20	85	16
400	M24	100	16
500	M24	100	20
600	M27	110	20
700	M27	115	24
800	M30	125	24
900	M30	125	28
1000	M33	140	28
1200	M36	160	32
1400	M39	175	36

Stud bolts BN6J - (wafer) EN 1092-1 (PN 10)					
DN	Thread K	L		L1	
		Length	Quantity	Length	Quantity
80	M16	155	4	75	8
100	M16	155	4	75	8
150	M20	185	4	85	8
200	M20	200	4	85	8
250	M20	230	8	90	8
300	M20	230	8	90	8
350	M20	245	12	90	8
400	M24	265	12	100	8
500	M24	285	16	105	8
600	M27	325	16	115	8
700	M27	385	20	120	8
800	M30	405	20	130	8
900	M30	405	24	130	8
1000	M33	490	20	145	16
1200	M36	565	24	165	16
1400	M39	635	28	180	16

Stud bolt dimensions ASME B16.47 / DIN EN 1092-1

Table 7-12 Stud bolts

Stud bolts BN3K - (double flange) EN 1092-1 (PN 16)			
DN	Thread K	L	
		Length	Quantity
80	M16	95	8
100	M16	95	8
150	M20	110	8
200	M20	115	12
250	M24	125	12
300	M24	130	12
350	M24	135	16
400	M27	150	16
500	M30	160	20
600	M33	185	20
700	M33	185	24
800	M36	190	24
900	M36	200	28
1000	M39	235	28
1200	M45	280	32
1400	M45	300	36

Stud bolts BN3L - (double flange) EN 1092-1 (PN 25)			
DN	Thread K	L	
		Length	Quantity
80	M16	105	8
100	M20	110	8
150	M24	130	8
200	M24	135	12
250	M27	145	12
300	M27	150	16
350	M30	160	16
400	M33	180	16
500	M33	195	20
600	M36	200	20
700	M39	210	24
800	M45	225	24
900	M45	235	28
1000	M52	265	28
1200	-	-	-
1400	-	-	-

Stud bolts BN4K - (mono flange) EN 1092-1 (PN 16)			
DN	Thread K	L	
		Länge	Quantity
80	M16	70	8
100	M16	70	8
150	M20	80	8
200	M20	85	12
250	M24	85	12
300	M24	85	12
350	M24	85	16
400	M27	100	16
500	M30	100	20
600	M33	110	20
700	M33	115	24
800	M36	125	24
900	M36	125	28
1000	M39	140	28
1200	M45	160	32
1400	M45	175	36

Stud bolts BN4L - (mono flange) EN 1092-1 (PN 25)			
DN	Thread K	L	
		Length	Quantity
80	M16	75	8
100	M20	75	8
150	M24	90	8
200	M24	95	12
250	M27	100	12
300	M27	105	16
350	M30	105	16
400	M33	120	16
500	M33	130	20
600	M36	135	20
700	M39	140	24
800	M45	155	24
900	M45	155	28
1000	M52	175	28
1200	-	-	-
1400	-	-	-

Stud bolts BN6K - (wafer) EN 1092-1 (PN 16)					
DN	Thread K	L		L1	
		Length	Quantity	Length	Quantity
80	M16	155	4	75	8
100	M16	155	4	75	8
150	M20	185	4	85	8
200	M20	200	8	85	8
250	M20	235	8	95	8
300	M20	240	8	95	8
350	M20	255	12	100	8
400	M24	285	12	110	8
500	M24	305	16	115	8
600	M27	355	16	130	8
700	M27	405	20	130	8
800	M30	420	20	140	8
900	M30	435	24	145	8
1000	M33	525	20	165	16
1200	M36	625	24	195	16
1400	M39	680	28	205	16

Stud bolts BN6L - (wafer) EN 1092-1 (PN 25)					
DN	Thread K	L		L1	
		Length	Quantity	Length	Quantity
80	M16	195	4	75	8
100	M20	205	4	80	8
150	M24	240	4	95	8
200	M24	290	8	95	8
250	M27	310	8	105	8
300	M27	345	8	105	8
350	M30	385	12	110	8
400	M33	405	12	125	8
500	M33	470	16	135	8
600	M36	520	16	140	8
700	M39	-	20	145	8
800	M45	-	20	160	8
900	M45	-	24	160	8
1000	M52	-	20	180	16
1200	-	-	24	-	16
1400	-	-	28	-	16

Tighten the stud bolts or nuts opposite to each other crosswise and evenly in accordance with the operator's specifications using a torque wrench (see fig. 9)

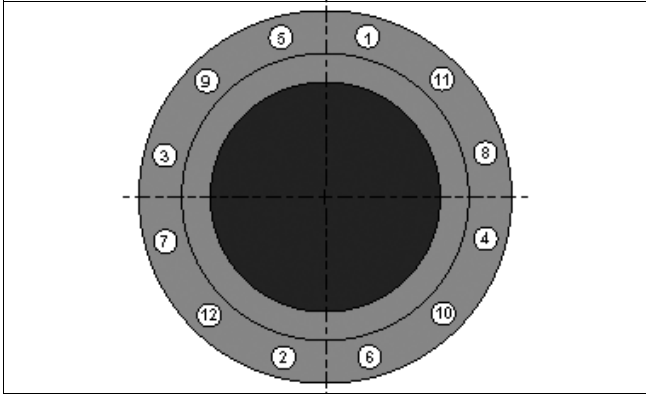


Fig. 9 Example for flange-mounting the pipelines with 12 flange holes in a crosswise fashion.

- Connect the energy supply last.

3.4 ATEX version

With ATEX valves the customer is responsible for grounding the valve correctly and in accordance with the regulations in the respective grounding. It is not permissible to operate the valve without adequate earthing. "The grounding connection is a marked screw with the Earthing symbol. This screw is a single, extra marked screw at, e.g., the body, flange or bracket. (see Fig. 10), Maintenance work on the valve may only be carried out by Valmet service staff or authorised personnel.

3.5 Dismounting the valve

Ensure that:

- The pipeline is unpressurised , empty and flushed.
- The relevant valve is disconnected from the process.
- The valve is in a defined position – usually closed.

Caution – danger of explosion! Follow all safety instructions provided by the operator!

Proceed as follows when dismounting the valve:

- Close the valve

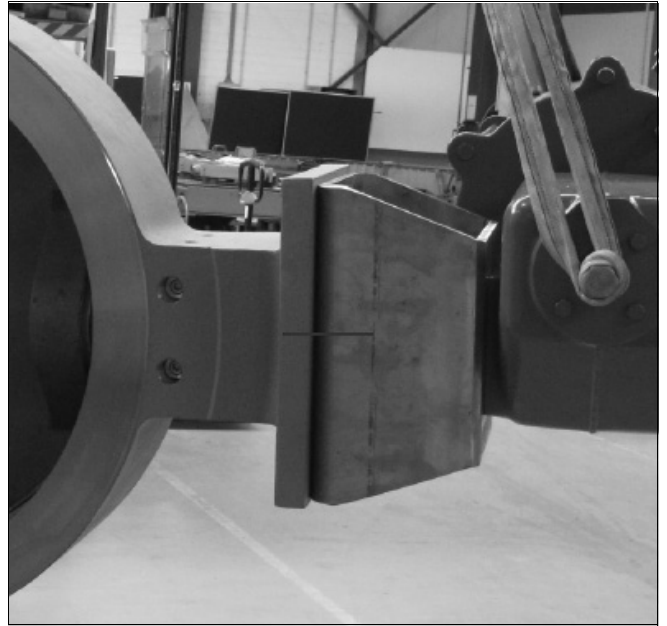


Fig. 10 Before detaching the actuator, mark its position in relation to the drive shaft and the disc on the bracket

If the actuator needs to be detached in order to dismount the valve, mark the position of the actuator on bracket and body with a permanent marker before detaching it (see fig. 11). In this way you can correctly position the actuator when refitting the valve and it cannot cause malfunction. Please see chapter 1 for further instructions on detaching the actuator.

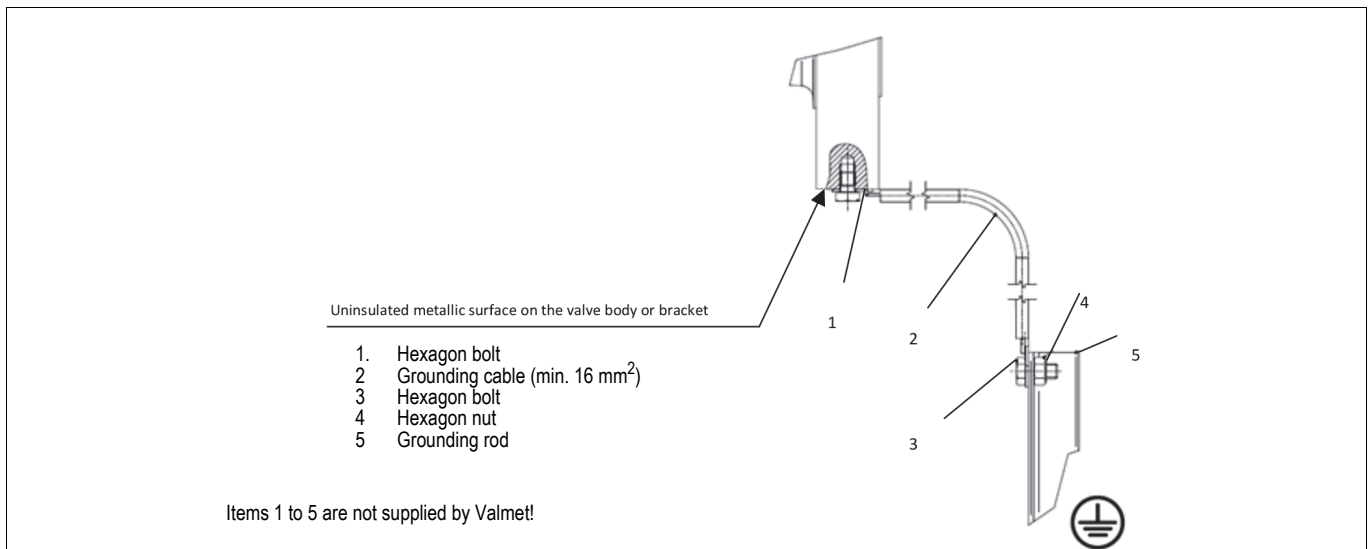


Fig. 11 Grounding

Switch off the energy supply to the actuator at the EMERGENCY-STOP switch for the actuator's energy supply or secure the remote control in such a way that nobody can switch the energy supply back on by mistake.

- Detach the actuator.
- Support the valve with safety ropes. Attach the ropes to the body (NOT the drive shaft) of the valve (see fig. 12).
- Dismount the valve by loosening the bolts or nuts opposite from each other in a crosswise fashion.
- Ensure that the valve is securely fastened during transport in order to protect it from damage.



Fig. 12 Securing the valve

3.6 Cleaning and maintenance intervals

CAUTION:
Observe the safety precautions mentioned in Section 1.1 before maintenance!

CAUTION:
When handling the valve or the valve package as a whole, bear in mind the weight of the valve or the entire package.

Although Neles valves are designed to work under severe conditions, proper preventative maintenance can significantly help to prevent unplanned downtime and in real terms reduce the total cost of ownership. Valmet recommends inspecting the valves regularly. Please see the preventive maintenance recommendations below.

The inspection and maintenance interval depends on the actual application and process condition.

The inspection and maintenance intervals can be specified together with your local Valmet experts. During this periodic inspection the parts detailed in the Spare Part Set(s) should be replaced.

Time in storage should be included in the inspection interval.

CAUTION:

Do not under any circumstances use pointy, abrasive or sharp tools (knives, files, screwdrivers etc.). And do not use any cleaning agents that might cause undesirable chemical reactions with the residues of the medium or might attack the sealing surface or the sealing element (320).

NOTE:

Check the valve's tightness regularly. We recommend replacing the elastomer sealing element (320) at least every two years or after 750 000 cycles.

Also check the condition of the O-ring seals (419, 470), the supporting rings (476), the shaft seal and the bushings (424) (see fig. 13).

NOTE:

At least every four years or after 1 500 000 cycles the high performance valve should be overhauled using the "Complete" spare part set. Please contact your Valmet service partner to arrange this.

NOTE:

When sending goods to the manufacturer for repair, do not disassemble them. Clean the valve carefully and flush the valve internals.

For safety reasons, inform the manufacturer of the type of medium used in the valve (include material safety datasheets (MSDS)).

NOTE:

In order to ensure safe and effective operation, always use original spare parts to make sure that the valve functions as intended.

NOTE:

For safety reasons, replace pressure retaining bolting if the threads are damaged, have been heated, stretched or corroded.

4 Tools

No special tools are required for maintenance work on the valve.

5 Ordering spare parts

The following information is required for ordering spare parts (from the identification plate, see fig. 3):

- The valve's serial number
- Plant name, date of commissioning
- The valve's type code
- A photo of the identification plate if possible
- ID number and quantity of the required spare part sets

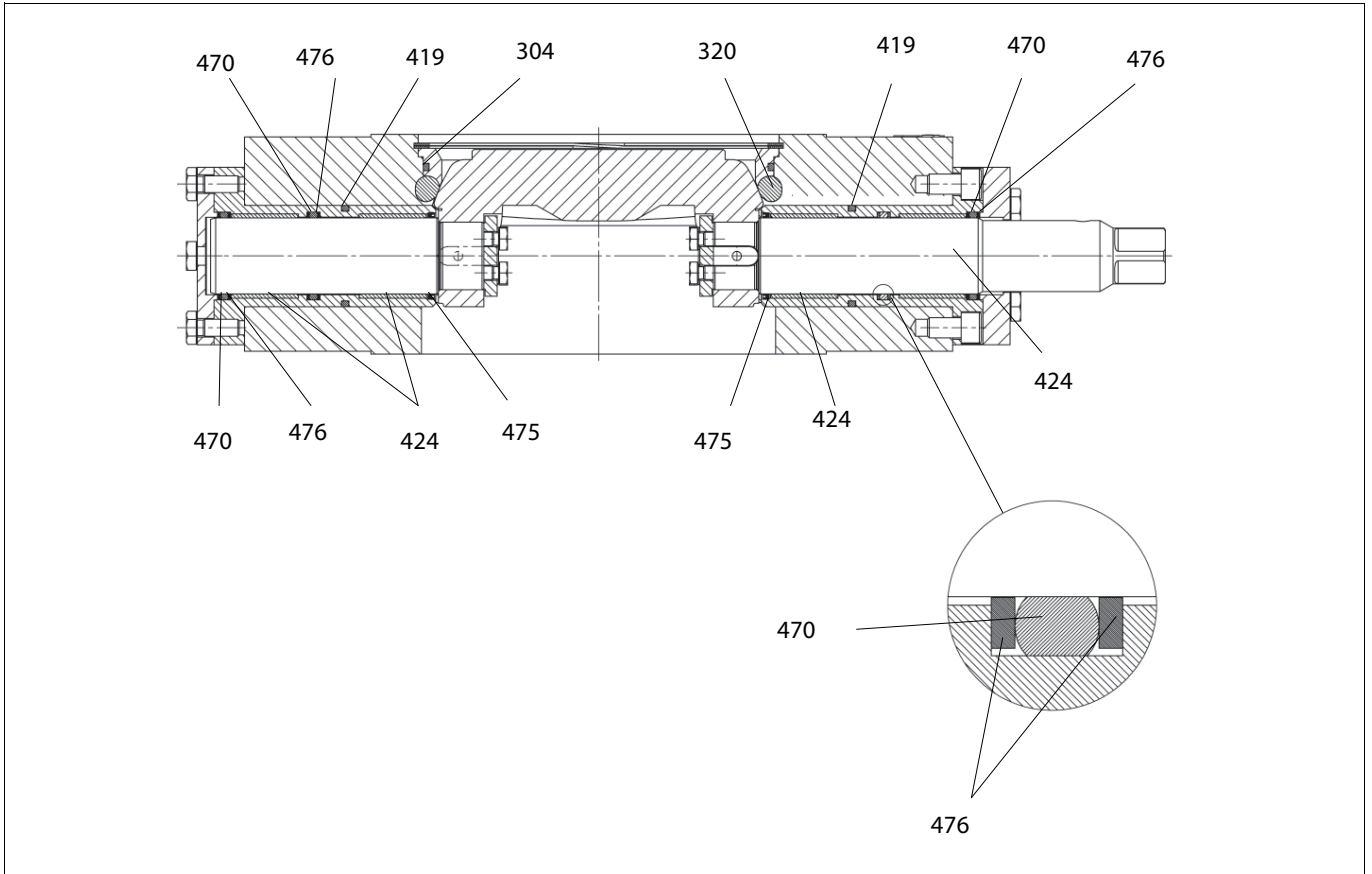


Fig. 13 Seals and bushings

6 Fitting and dismantling type A/F and B1C actuators

6.1 General information

CAUTION:

When handling the valve or the entire valve unit, bear in mind its weight!

The actuator must not be detached from the valve if the pipeline is under pressure due to dynamic torque! Do not dismantle a spring-return actuator without securing the spring with a stop screw first!

NOTE:

Before detaching the actuator, take note of the valve position in relation to actuator and positioner / limit switch to ensure that the unit can be reassembled correctly. The actuator must be positioned in such a way that it is always freely accessible, particularly for a potential manual emergency override

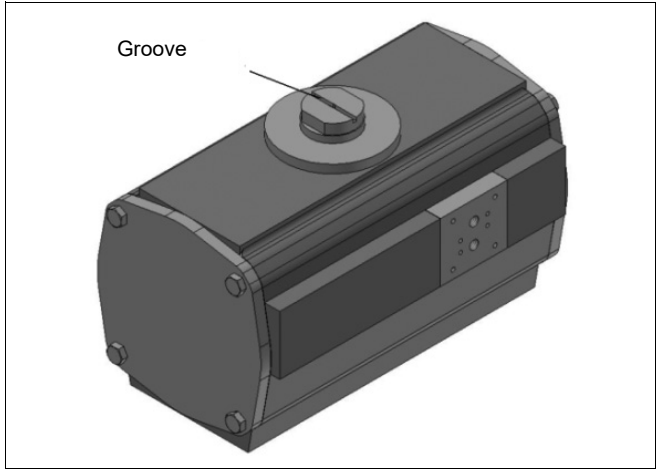


Fig. 15 The groove on the actuating shaft corresponds to the position of the disc

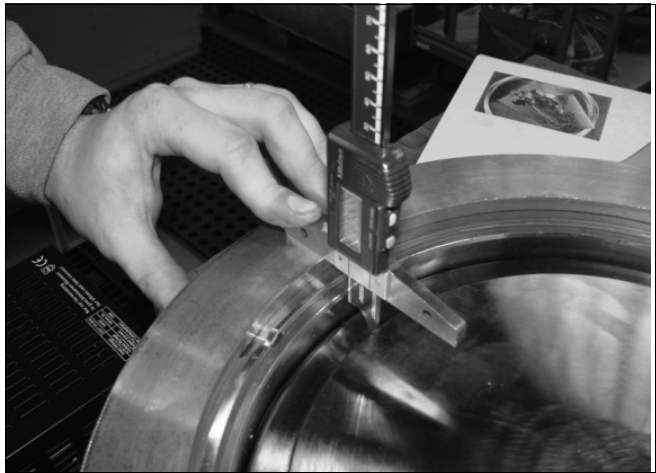


Fig. 16 Checking the closed position by measuring the depth



Fig. 14 Example of actuator F1 identification plate

Table 13 Actuator sizes

Actuator type	Actuator size											
	30	60	120	250	500							
Double-acting, type A (kg)	10	16	28	51	100							
Single-acting, type F (kg)	13	21	56	85	160							
Actuator type	B1C6	B1C9	B1C11	B1C13	B1C17	B1C20	B1C25	B1C32	B1C40	B1C50	B1C60	B1C75
Double-acting, type B1C (kg)	4,2	9,6	16	31	54	73	131	256	446	830	1080	1190
Actuator type	B1J, B1JA8	B1J, B1JA10	B1J, B1JA12	B1J, B1JA16	B1J, B1JA20	B1J, B1JA25	B1J, B1JA32					
Single-acting, type B1J, B1JA (kg)	17	30	57	100	175	350	671					

6.2 Mounting preparations

For larger actuators a hoist is required to lift the unit into place. The actuator type and the actuator size are specified on the identification plate (fig. 14, actuator identification plate). The actuator weight is indicated in the following table.

6.3 Mounting a type A/F actuator

When mounting the actuator, proceed as follows:

- Before attaching the actuator, turn the valve into the closed position.
- Carefully slip the actuating shaft onto the valve shaft. Make sure that the actuator is mounted flush to the bracket so that the drive shaft will not be subjected to any stress.
- Ensure that the notch on the actuating shaft corresponds to the position of the disc (see fig. 15).

- Attach the actuator to the bracket using four bolts and tighten those crosswise. Please note: the A/F actuator bodies are made from aluminium. Over-tightening of the bolts may cause damage to the mounting threads. See 12.8 for torque settings. Then re-check the valve's closed position by means of several depth measurements. The various measured values must not deviate by more than 0.3 mm from each other (see fig. 16).
- Lastly, connect the energy supply (see fig. 17).

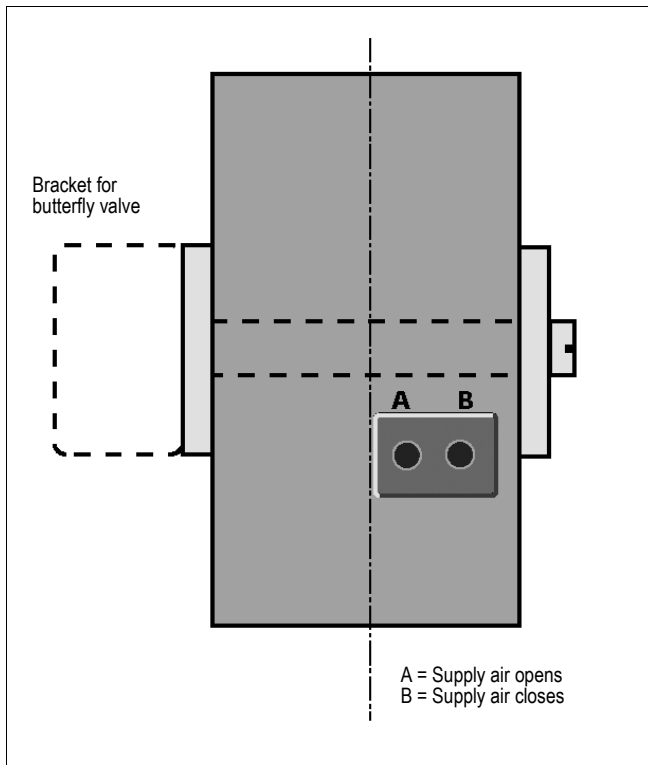


Fig. 17 Pneumatic connection

6.4 Dismounting preparation

If the actuator is fitted to a pipeline, the following conditions must be met before dismounting it:

- Ensure that detaching the actuator will not cause malfunction.
- Carefully check if a hot medium has flown through the pipeline and if the actuator has cooled sufficiently so that there is no further danger from extreme temperatures.
- Ensure that there is no danger for the service engineer from the medium that has flown through the valve last.

If you do not carry out the work yourself, please warn service personnel of potential hazards.

6.5 Dismounting type A/F

Proceed in the following sequence when detaching the actuator.

If the actuator of a valve that is installed in a pipeline is to be replaced, ensure that:

- The pipeline is depressurised and the relevant valve is uncoupled from the process.
- The valve is in a defined position – usually closed.
- Switch off the energy supply to the actuator at the EMERGENCY-STOP switch for the actuator's energy supply or secure the remote control in such a way that nobody can switch the energy supply back on by mistake.
- Support the actuator with safety ropes.
- Unscrew the bolts between bracket and actuator and carefully pull the actuator off the valve's drive shaft.

- Ensure that the actuator is securely fastened during transport in order to protect it from damage.

If you are using a remote control to operate the actuator, a mechanism for interrupting the energy supply (e.g. an EMERGENCY-STOP switch) must be fitted to the actuator.



6.6 Mounting a B1C type actuator to the valve

CAUTION:

When handling the actuator or the valve unit, bear in mind its weight!

CAUTION:

Beware of the disc's cutting movement!

The actuator is mounted directly via the actuator's shaft hole. Should the bore hole be wider than the shaft diameter, an intermediate shaft bushing must be used. The actuator shaft bore features two sets of grooves for the mounting brackets at an angle of 90° from each other. In this way the mounting position of the actuator in relation to the valve can be varied. The ends of Neles valve shafts are bevelled for easier mounting.

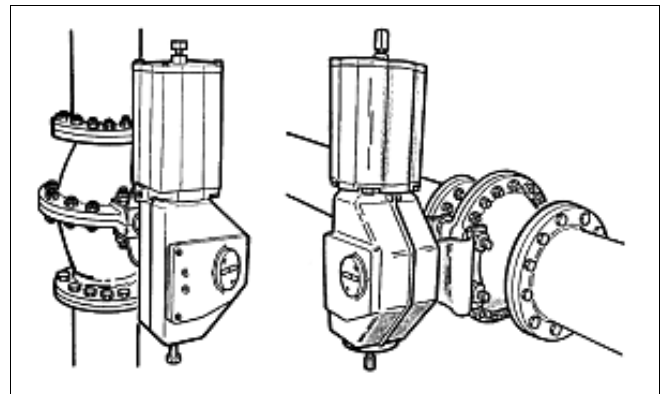


Fig. 18 Possible orientations of the actuator

The orientation of the actuator can be selected freely. However, Valmet recommends mounting the actuator with the cylinder in an upright position. In this way the actuator is optimally protected from possible damage due to impurities in the supply air or water. If the position of the actuator in relation to the valve is changed, the arrow of the position indicator must also be turned in order to reflect the actual operating mode of the valve.

If necessary, lubricate the actuator bore and the intermediate bushing with Cortec VCI 369 or a similar anti-corrosive lubricant in order to protect them from seizing due to corrosion.

The actuator should not touch the pipeline since pipeline vibrations might damage the actuator or impair its function.

In certain cases, e.g. with large actuators or extended shafts as well as strong pipeline vibrations, the actuator should be supported. Please contact Valmet division for further information and instructions.

Two adjusting screws on the actuator limit the travel in the end positions. The actuator creates 1.5 times more torque than nominal torque, when the piston is positioned at the top-end of the cylinder (see fig. 19). For some valve types, e.g. butterfly valves, closing torque and position are very exact. The stop screw on the cylinder must be adjusted correctly. An O-ring seal (33A) is used for sealing the stop screw at the cylinder end. More information on these settings can be found in the instructions for the individual valves.

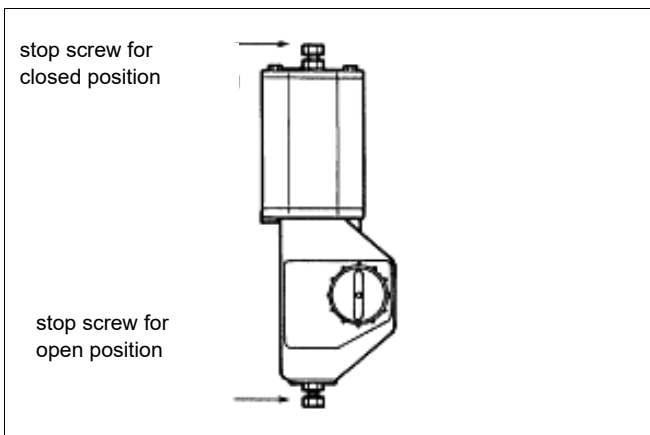


Fig. 19 The stop screws for the open and closed positions

6.7 Detaching the actuator from the valve

The actuator must be depressurised and the air supply pipe must be detached. Unscrew the bracket screws at the side of the actuator, take out the screws and pull the actuator of the valve shaft. Ideally, this should be done with a special pull-off device (see fig. 20). Mark the position of the valve in relation to the actuator in order to ensure correct function of the valve after reinstallation.

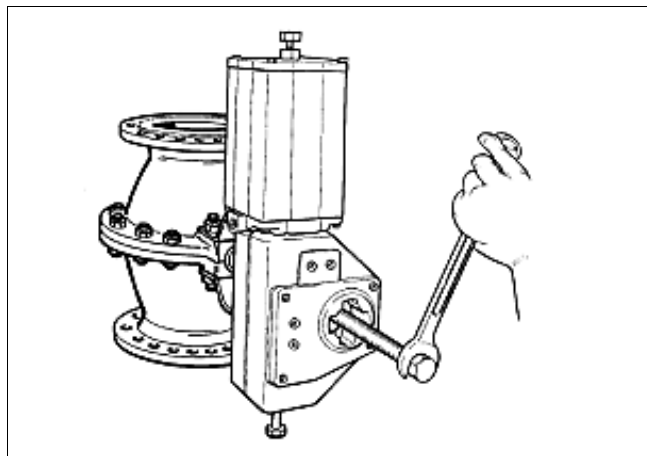
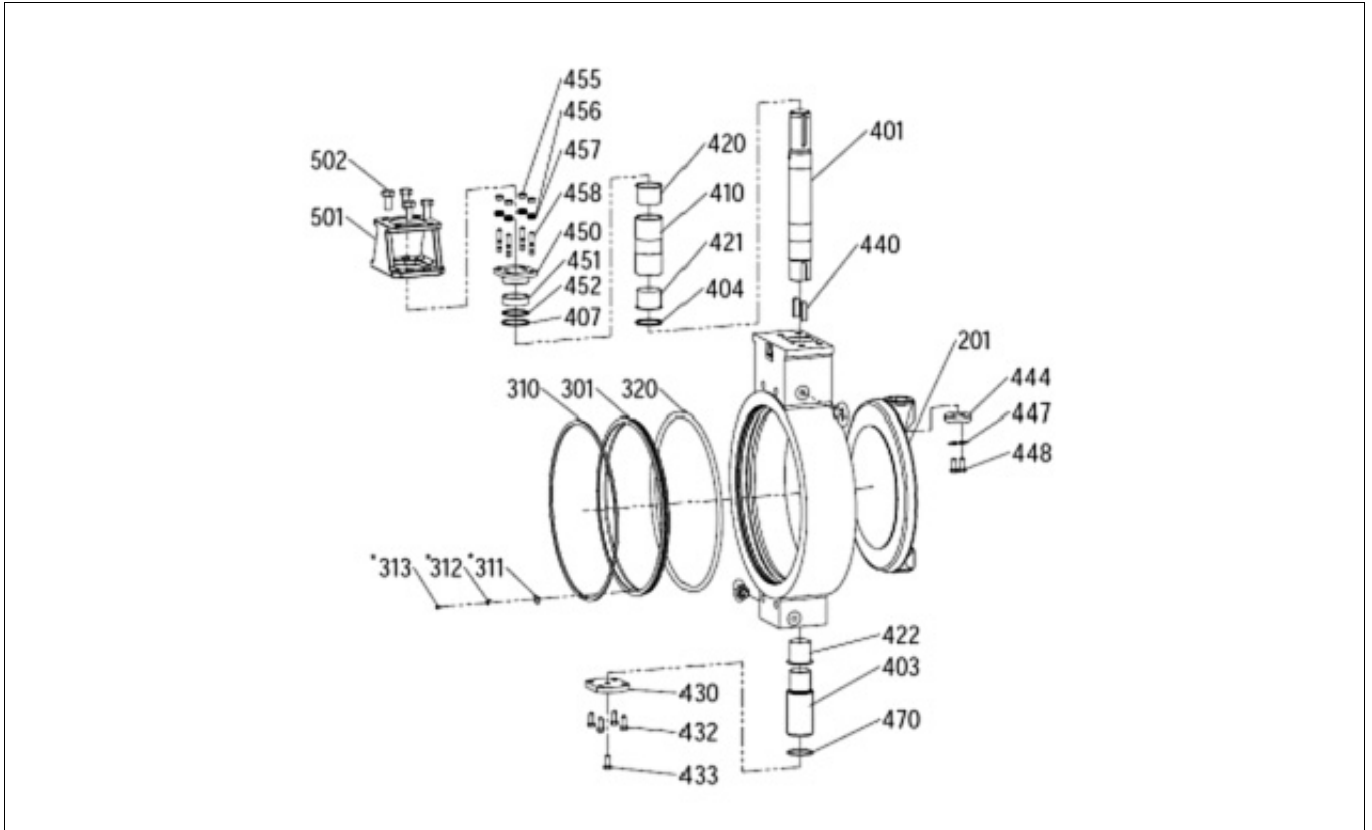


Fig. 20 Removing the actuator with a pull-off device

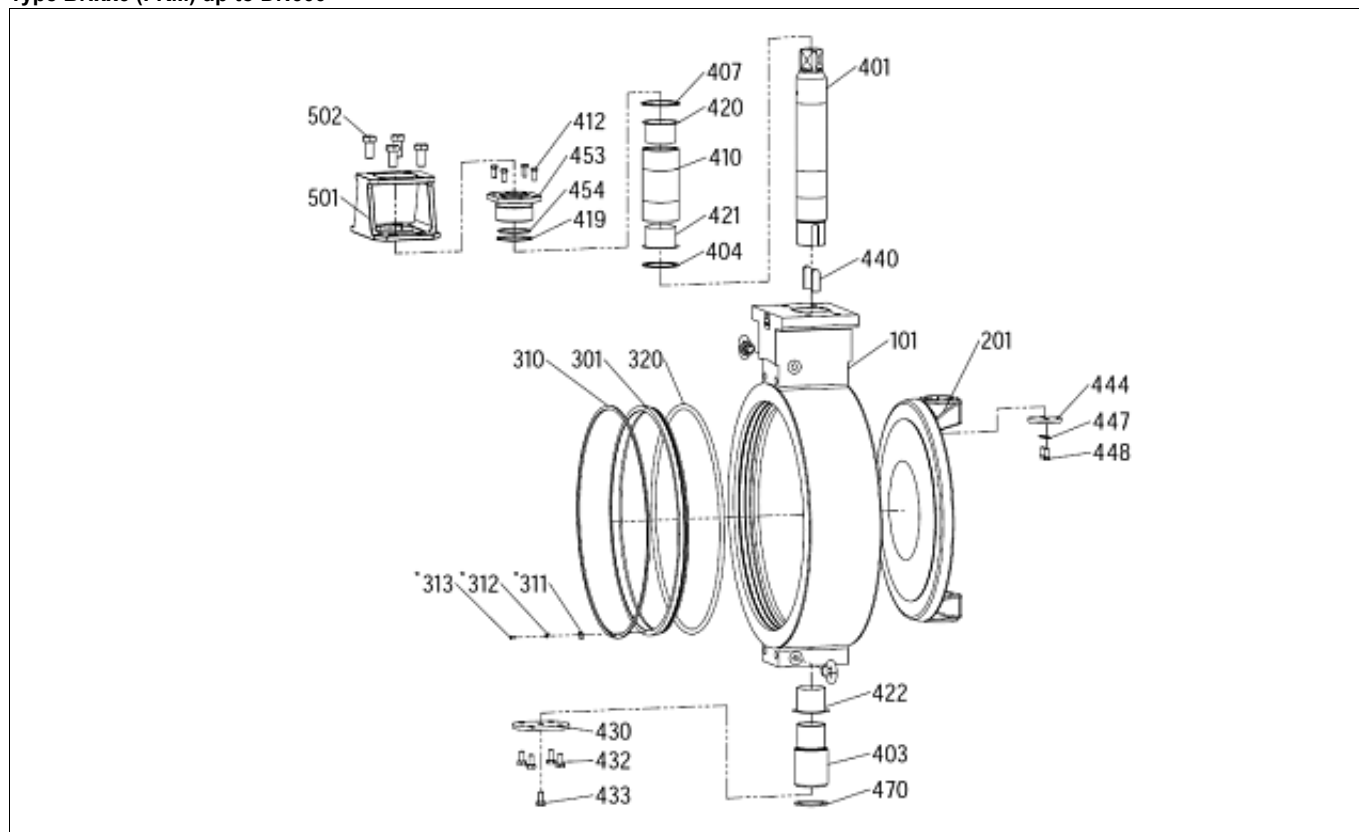
7 Exploded view & BOM

Type BNxx6 (PTFE) up to DN600



Position no.	Description	Comment
101	BODY	
117	SIGN CLOSED	
118	EYE BOLT	
201	DISC	
301	SEAL RING	
310	RETAINING RING	
311	CLAMPING SHOE	* only for bigger than DN600 / NPS24
312	LOCKING SHIM	* only for bigger than DN600 / NPS24
313	HEXAGON SCREW	* only for bigger than DN600 / NPS24
320	SEALING ELEMENT	
401	SHAFT	
403	TRUNNION	
404	THRUST WASHER	
407	RETAINING RING	
411	BEARING SLEEVE	
412	HEXAGON SCREW	
419	O-RING	
420	BEARING BUSHING	
421	BEARING BUSHING	
422	BEARING BUSHING	
430	COVER	
432	HEXAGON SCREW	
433	HEXAGON SCREW	
440	FEATHER KEY	
444	CLAMP DISC	
447	LOCKING SHIM	
448	HEXAGON SCREW	
453	SEALING FLANGE	
454	O-RING	
470	O-RING	
501	BRACKET	
502	HEXAGON SCREW	

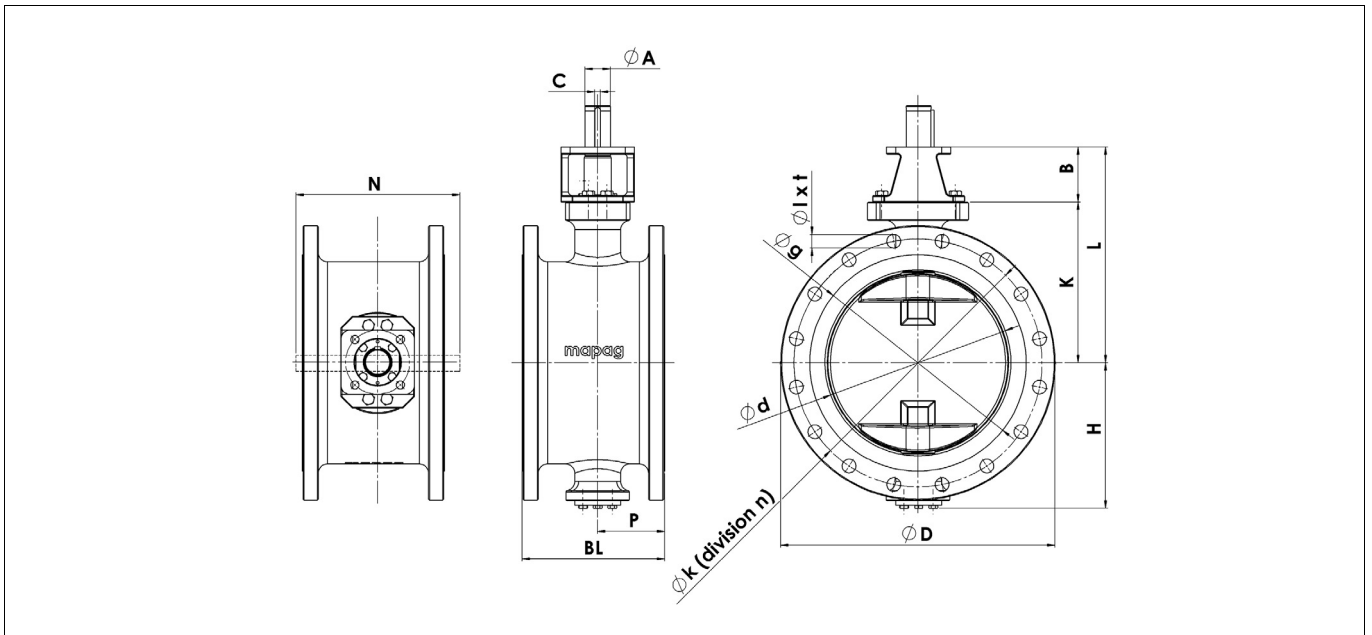
Type BNxx6 (FKM) up to DN600



Position no.	Description	Comment
101	BODY	
117	SIGN CLOSED	
118	EYE BOLT	
201	DISC	
301	SEAL RING	
310	RETAINING RING	
311	CLAMPING SHOE	* only for bigger than DN600 / NPS24
312	LOCKING SHIM	* only for bigger than DN600 / NPS24
313	HEXAGON SCREW	* only for bigger than DN600 / NPS24
320	SEALING ELEMENT	
401	SHAFT	
403	TRUNNION	
404	THRUST WASHER	
407	RETAINING RING	
411	BEARING SLEEVE	
412	HEXAGON SCREW	
419	O-RING	
420	BEARING BUSHING	
421	BEARING BUSHING	
422	BEARING BUSHING	
430	COVER	
432	HEXAGON SCREW	
433	HEXAGON SCREW	
440	FEATHER KEY	
444	CLAMP DISC	
447	LOCKING SHIM	
448	HEXAGON SCREW	
450	GLAND	
451	GLAND PACKING	
452	BOTTOM RING	
455	HEXAGON NUT	
456	WASHER	
457	DISC SPRING	
458	THREADED PIN	
470	O-RING	
501	BRACKET	
502	HEXAGON SCREW	

8 Weights and dimensions

Type BN3



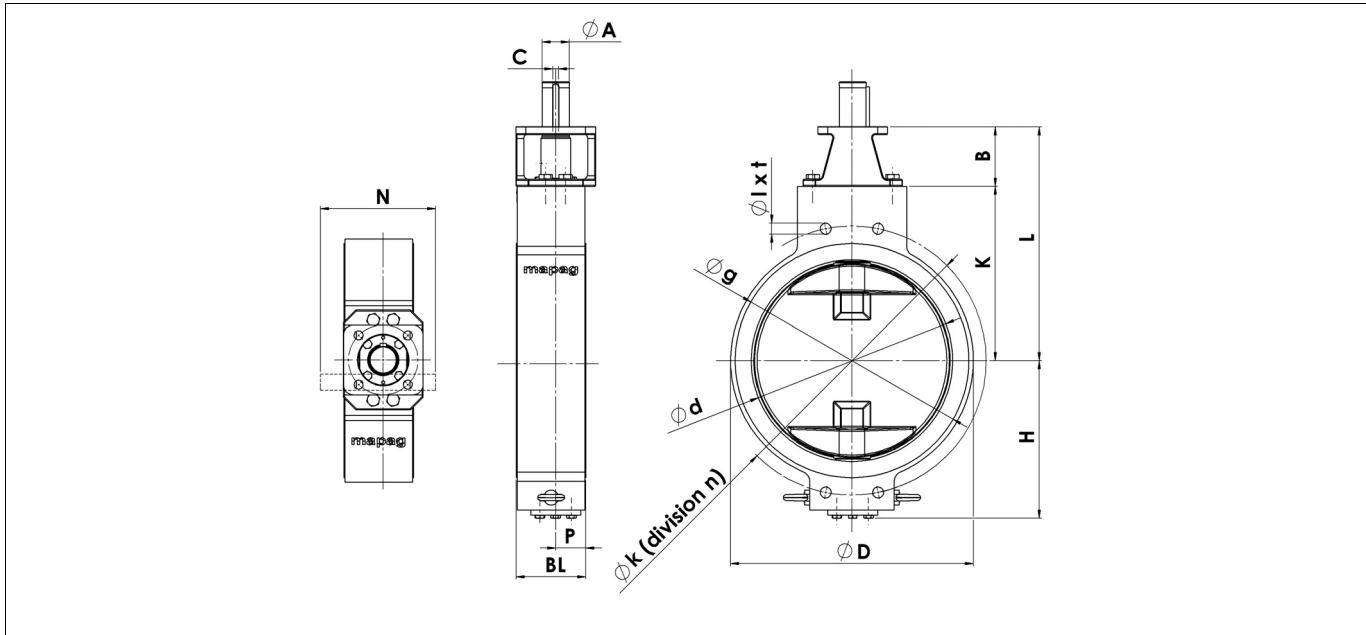
NPS	Standard Dimensions											ASME B 16.5 - Cl150				ASME B 16.47 Series B - Cl150			
	BL	ØD	H	K	B	L	P	N	Ød	ØA	C	Øg	Øk	n	Øl	Øg	Øk	n	Øl
3	180	190	120	130	90	220	90	81	92	20	3/16"	127,0	152,4	4	20				
4	190	230	130	145	90	235	95	103	110	20	3/16"	157,2	190,5	8	20				
6	210	280	155	180	90	270	105	146,5	160	25	1/4"	215,9	241,3	8	23				
8	230	345	200	210	110	320	115	198	210	30	1/4"	269,9	295,5	8	23				
10	250	405	220	260	110	370	125	244	255	35	3/8"	323,8	362,0	12	25,5				
12	270	485	265	300	110	410	135	290	302	40	3/8"	381,0	431,8	12	25,5				
14	290	535	290	320	120	440	145	337	350	45	1/2"	412,8	476,3	12	29				
16	310	595	330	350	120	470	155	392	405	50	1/2"	469,9	539,8	16	29				
20	350	700	400	440	140	580	175	487	505	65	5/8"	584,2	635,0	20	32				
24	390	815	455	535	180	715	195	591	610	70	3/4"	692,2	749,3	20	35				
28	430	835	480	620	180	800	215	672	700	75	3/4"					762	795,3	40	23
32	470	940	540	680	220	900	235	737	760	75	3/4"					864	900,1	48	23
36	510	1055	600	820	220	1040	255	869	900	85	7/8"					972	1009,6	44	25,5
40	550	1175	710	860	220	1080	275	947	966	95	7/8"					1080	1120,8	44	29
48	630	1390	750	800	220	1020	315	1156	1185	95	7/8"					1289	1335,1	44	32
56	710	1600	935	1025	220	1245	355	1346	1370	105	1"					1492	1543,0	60	32
64	790					0	395												

wird bei Auftragserteilung definiert

DN	Standard Dimensions											DIN EN 1092-1 PN10			
	BL	ØD	H	K	B	L	P	N	Ød	ØA	C	Øg	Øk	n	Øl
80	180	200	120	130	90	220	90	81	92	20	3/16"	138	160	8	18
100	190	220	130	145	90	235	95	103	110	20	3/16"	158	180	8	18
150	210	285	155	180	90	270	105	146,5	160	25	1/4"	212	240	8	22
200	230	340	200	210	110	320	115	198	210	30	1/4"	268	295	8	22
250	250	395	220	260	110	370	125	244	255	35	3/8"	320	350	12	22
300	270	445	265	300	110	410	135	290	302	40	3/8"	370	400	12	22
350	290	505	290	320	120	440	145	337	350	45	1/2"	430	460	16	22
400	310	565	330	350	120	470	155	392	405	50	1/2"	482	515	16	26
500	350	670	400	440	140	580	175	487	505	65	5/8"	585	620	20	26
600	390	780	455	535	180	715	195	591	610	70	3/4"	685	725	20	30
700	430	895	480	620	180	800	215	672	700	75	3/4"	800	840	24	30
800	470	1015	540	680	220	900	235	737	760	75	3/4"	905	950	24	33
900	510	1115	600	820	220	1040	255	869	900	85	7/8"	1005	1050	28	33
1000	550	1230	710	860	220	1080	275	947	966	95	7/8"	1110	1160	28	36
1200	630	1455	750	800	220	1020	315	1156	1185	95	7/8"	1330	1380	32	39
1400	710	1675	935	1025	220	1245	355	1346	1370	105	1"	1535	1590	36	42
1600	790	1915				0	395					1760	1820	40	48

DN	Standard Dimensions											DIN EN 1092-1 PN16			
	BL	ØD	H	K	B	L	P	N	Ød	ØA	C	Øg	Øk	n	Øl
80	180	200	120	130	90	220	90	81	92	20	3/16"	138	160	8	18
100	190	220	130	145	90	235	95	103	110	20	3/16"	158	180	8	18
150	210	285	155	180	90	270	105	146,5	160	25	1/4"	212	240	8	22
200	230	340	200	210	110	320	115	198	210	30	1/4"	268	295	12	22
250	250	405	220	260	110	370	125	244	255	35	3/8"	320	355	12	26
300	270	460	265	300	110	410	135	290	302	40	3/8"	378	410	12	26
350	290	520	290	320	120	440	145	337	350	45	1/2"	438	470	16	26
400	310	580	330	350	120	470	155	392	405	50	1/2"	490	525	16	30
500	350	715	400	440	140	580	175	487	505	65	5/8"	610	650	20	33
600	390	840	455	535	180	715	195	591	610	70	3/4"	725	770	20	36
700	430	910	480	620	180	800	215	672	700	75	3/4"	795	840	24	36
800	470	1025	540	680	220	900	235	737	760	75	3/4"	900	950	24	39
900	510	1125	600	820	220	1040	255	869	900	85	7/8"	1000	1050	28	39
1000	550	1255	710	860	220	1080	275	947	966	95	7/8"	1115	1170	28	42
1200	630	1485	750	800	220	1020	315	1156	1185	95	7/8"	1330	1390	32	48
1400	710	1685	935	1025	220	1245	355	1346	1370	105	1"	1530	1590	36	48
1600	790	1930				0	395					1750	1820	40	56

Type BN6

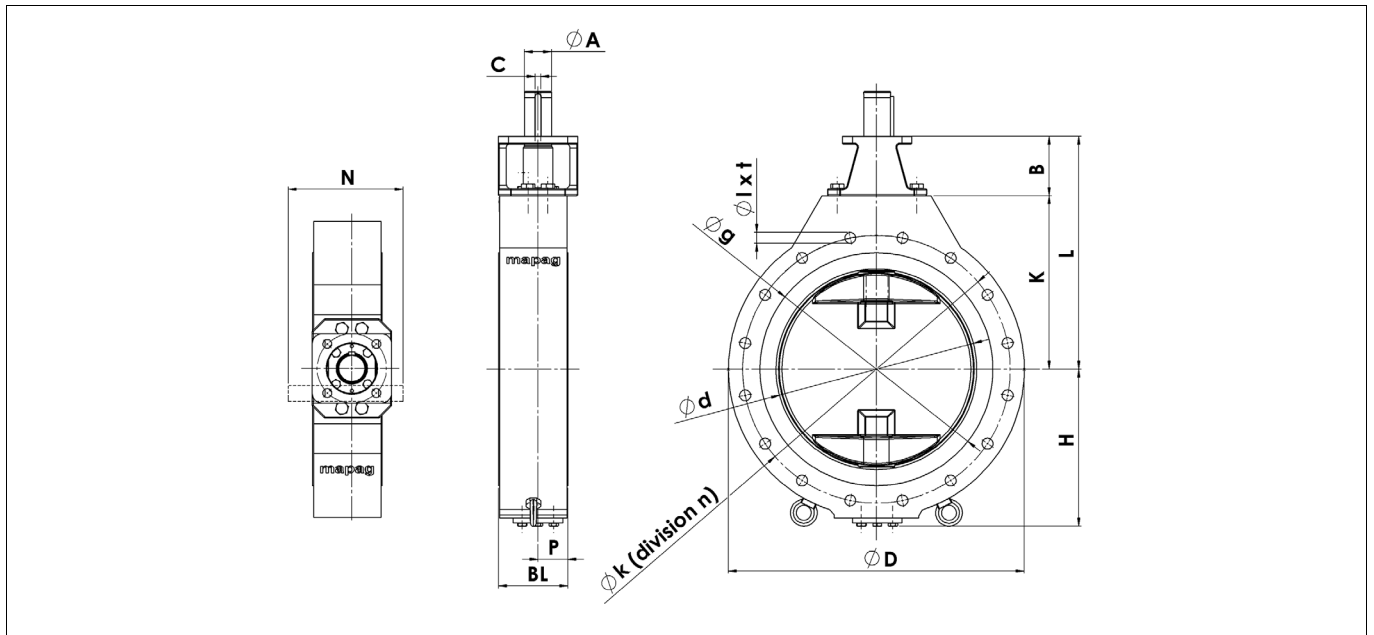


NPS	Standard Dimensions											ASME B 16.5 - Cl150				ASME B 16.47 Series B - Cl150			
	BL	ØD	H	K	B	L	P	N	Ød	ØA	C	Øg	Øk	n	Øl / thread	Øg	Øk	n	Øl / thread
3	64	190	120	130	90	220	36	81	92	20	3/16"	127,0	152,4	4	5/8"-UNC				
4	64	230	130	145	90	235	36	103	110	20	3/16"	157,2	190,5	8	5/8"-UNC				
6	76	280	155	180	90	270	47	146,5	160	25	1/4"	215,9	241,3	8	3/4"-UNC				
8	89	345	200	210	110	320	55	198	210	30	1/4"	269,9	298,5	8	3/4"-UNC				
10	114	405	220	260	110	370	73	244	255	35	3/8"	323,8	362,0	12	7/8"-UNC				
12	114	485	265	300	110	410	72	290	302	40	3/8"	381,0	431,8	12	7/8"-UNC				
14	127	535	290	320	120	440	83	337	350	45	1/2"	412,8	476,3	12	1"-8UN				
16	140	595	330	350	120	470	79,3	392	405	50	1/2"	469,9	539,8	16	1"-8UN				
20	152	700	400	440	140	580	98	487	505	65	5/8"	584,2	635,0	20	1 1/8"-8UN				
24	178	815	455	535	180	715	115	591	610	70	3/4"	692,2	749,3	20	1 1/4"-8UN				
28	229	835	480	620	180	800	134	672	700	75	3/4"				762	795,3	40	3/4"-UNC	
32	241	940	540	680	220	900	136	737	760	75	3/4"				864	900,1	48	3/4"-UNC	
36	241	1055	600	820	220	1040	145	869	900	85	7/8"				972	1009,6	44	7/8"-UNC	
40	300	1175	710	860	220	1080	155	947	966	95	7/8"				1080	1120,8	44	1"-8UN	
48	350	1390	750	900	220	1120	172,5	1156	1185	95	7/8"				1289	1335,1	44	1 1/8"-8UN	
56	390	1600	935	1025	220	1245	230	1346	1370	105	1"				1492	1543,0	60	1 1/8"-8UN	
64	440					0	230												wird bei Auftragserteilung definiert

DN	Standard Dimensions											DIN EN 1092-1 PN10			
	BL	ØD	H	K	B	L	P	N	Ød	ØA	C	Øg	Øk	n	Øl / thread
80	64	200	120	130	90	220	40	81	92	20	3/16"	138	160	8	M16
100	64	220	130	145	90	235	41	103	110	20	3/16"	158	180	8	M16
150	76	285	155	180	90	270	47	146,5	160	25	1/4"	212	240	8	M20
200	89	340	200	210	110	320	55	198	210	30	1/4"	268	295	8	M20
250	114	395	220	260	110	370	73	244	255	35	3/8"	320	350	12	M20
300	114	445	265	300	110	410	72	290	302	40	3/8"	370	400	12	M20
350	127	505	290	320	120	440	83	337	350	45	1/2"	430	460	16	M20
400	140	565	330	350	120	470	79,3	392	405	50	1/2"	482	515	16	M24
500	152	670	400	440	140	580	98	487	505	65	5/8"	585	620	20	M24
600	178	780	455	535	180	715	115	591	610	70	3/4"	685	725	20	M27
700	229	895	480	620	180	800	134	672	700	75	3/4"	800	840	24	M27
800	241	1015	540	680	220	900	136	737	760	75	3/4"	905	950	24	M30
900	241	1115	600	820	220	1040	145	869	900	85	7/8"	1005	1050	28	M30
1000	300	1230	710	860	220	1080	155	947	966	95	7/8"	1110	1160	28	M33
1200	350	1455	750	900	220	1020	172,5	1156	1185	95	7/8"	1330	1380	32	M36
1400	390	1675	935	1025	220	1245	230	1346	1370	105	1"	1535	1590	36	M39
1600	440	1915				0	230					1760	1820	40	M45

DN	Standard Dimensions											DIN EN 1092-1 PN16			
	BL	ØD	H	K	B	L	P	N	Ød	ØA	C	Øg	Øk	n	Øl / thread
80	64	200	120	130	90	220	40	81	92	20	3/16"	138	160	8	M16
100	64	220	130	145	90	235	41	103	110	20	3/16"	158	180	8	M16
150	76	285	155	180	90	270	47	146,5	160	25	1/4"	212	240	8	M20
200	89	340	200	210	110	320	55	198	210	30	1/4"	268	295	12	M20
250	114	405	220	260	110	370	73	244	255	35	3/8"	320	355	12	M24
300	114	460	265	300	110	410	72	290	302	40	3/8"	378	410	12	M24
350	127	520	290	320	120	440	83	337	350	45	1/2"	438	470	16	M24
400	140	580	330	350	120	470	79,3	392	405	50	1/2"	490	525	16	M27
500	152	715	400	440	140	580	98	487	505	65	5/8"	610	650	20	M30
600	178	840	455	535	180	715	115	591	610	70	3/4"	725	770	20	M33
700	229	910	480	620	180	800	134	672	700	75	3/4"	795	840	24	M33
800	241	1025	540	680	220	900	136	737	760	75	3/4"	900	950	24	M36
900	241	1125	600	820	220	1040	145	869	900	85	7/8"	1000	1050	28	M36
1000	300	1255	710	860	220	1080	155	947	966	95	7/8"	1115	1170	28	M39
1200	350	1485	750	900	220	1020	172,5	1156	1185	95	7/8"	1330	1390	32	M45
1400	390	1685	935	1025	220	1245	230	1346	1370	105	1"	1530	1590	36	M45
1600	440	1930				0	230					1750	1820	40	M52

Type BN4



NPS	Standard Dimensions										ASME B 16.5 - Cl150					ASME B 16.47 Series B - Cl150			
	BL	ØD	H	K	B	L	P	N	Ød	ØA	C	Øg	Øk	n	Øl / thread	Øg	Øk	n	Øl / thread
3	64	190	120	130	90	220	36	81	92	20	3/16"	127,0	152,4	4	20 / 5/8"-UNC				
4	64	230	130	145	90	235	36	103	110	20	3/16"	157,2	190,5	8	20 / 5/8"-UNC				
6	76	280	155	180	90	270	47	146,5	160	25	1/4"	215,9	241,3	8	23 / 3/4"-UNC				
8	89	345	200	210	110	320	55	198	210	30	1/4"	269,9	298,5	8	23 / 3/4"-UNC				
10	114	405	220	260	110	370	73	244	255	35	3/8"	323,8	362,0	12	25,5 / 7/8"-UNC				
12	114	485	265	300	110	410	72	290	302	40	3/8"	381,0	431,8	12	25,5 / 7/8"-UNC				
14	127	535	290	320	120	440	83	337	350	45	1/2"	412,8	476,3	12	29 / 1"-8UN				
16	140	595	330	350	120	470	79,3	392	405	50	1/2"	469,9	539,8	16	29 / 1"-8UN				
20	152	700	400	440	140	580	98	487	505	65	5/8"	584,2	635,0	20	32 / 1 1/8"-8UN				
24	178	815	455	535	180	715	115	591	610	70	3/4"	692,2	749,3	20	35 / 1 1/4"-8UN				
28	229	835	480	620	180	800	134	672	700	75	3/4"					762	795,3	40	23 / 3/4"-UNC
32	241	940	540	680	220	900	136	737	760	75	3/4"					864	900,1	48	23 / 3/4"-UNC
36	241	1055	600	820	220	1040	145	869	900	85	7/8"					972	1009,6	44	25,5 / 7/8"-UNC
40	300	1175	710	860	220	1080	155	947	966	95	7/8"					1080	1120,8	44	29 / 1"-8UN
48	350	1390	750	800	220	1020	172,5	1156	1185	95	7/8"					1289	1335,1	44	32 / 1 1/8"-8UN
56	390	1600	935	1025	220	1245	230	1346	1370	105	1"					1492	1543,0	60	32 / 1 1/8"-8UN
64	440					0	230												wird bei Auftragserteilung definiert

DN	Standard Dimensions										DIN EN 1092-1 PN10				
	BL	ØD	H	K	B	L	P	N	Ød	ØA	C	Øg	Øk	n	Øl / thread
80	64	200	120	130	90	220	40	81	92	20	3/16"	138	160	8	18 / M16
100	64	220	130	145	90	235	41	103	110	20	3/16"	158	180	8	18 / M16
150	76	285	155	180	90	270	47	146,5	160	25	1/4"	212	240	8	22 / M20
200	89	340	200	210	110	320	55	198	210	30	1/4"	268	295	8	22 / M20
250	114	395	220	260	110	370	73	244	255	35	3/8"	320	350	12	22 / M20
300	114	445	265	300	110	410	72	290	302	40	3/8"	370	400	12	22 / M20
350	127	505	290	320	120	440	83	337	350	45	1/2"	430	460	16	22 / M20
400	140	565	330	350	120	470	79,3	392	405	50	1/2"	482	515	16	26 / M24
500	152	670	400	440	140	580	98	487	505	65	5/8"	585	620	20	26 / M24
600	178	780	455	535	180	715	115	591	610	70	3/4"	685	725	20	30 / M27
700	229	895	480	620	180	800	134	672	700	75	3/4"	800	840	24	30 / M27
800	241	1015	540	680	220	900	136	737	760	75	3/4"	905	950	24	33 / M30
900	241	1115	600	820	220	1040	145	869	900	85	7/8"	1005	1050	28	33 / M30
1000	300	1230	710	860	220	1080	155	947	966	95	7/8"	1110	1160	28	36 / M33
1200	350	1455	750	800	220	1020	172,5	1156	1185	95	7/8"	1330	1380	32	39 / M36
1400	390	1675	935	1025	220	1245	230	1346	1370	105	1"	1535	1590	36	42 / M39
1600	440	1915				0	230					1760	1820	40	48 / M45

DN	Standard Dimensions										DIN EN 1092-1 PN16				
	BL	ØD	H	K	B	L	P	N	Ød	ØA	C	Øg	Øk	n	Øl / thread
80	64	200	120	130	90	220	40	81	92	20	3/16"	138	160	8	18 / M16
100	64	220	130	145	90	235	41	103	110	20	3/16"	158	180	8	18 / M16
150	76	285	155	180	90	270	47	146,5	160	25	1/4"	212	240	8	22 / M20
200	89	340	200	210	110	320	55	198	210	30	1/4"	268	295	12	22 / M20
250	114	405	220	260	110	370	73	244	255	35	3/8"	320	355	12	26 / M24
300	114	460	265	300	110	410	72	290	302	40	3/8"	378	410	12	26 / M24
350	127	520	290	320	120	440	83	337	350	45	1/2"	438	470	16	26 / M24
400	140	580	330	350	120	470	79,3	392	405	50	1/2"	490	525	16	30 / M27
500	152	715	400	440	140	580	98	487	505	65	5/8"	610	650	20	33 / M30
600	178	840	455	535	180	715	115	591	610	70	3/4"	725	770	20	36 / M33
700	229	910	480	620	180	800	134	672	700	75	3/4"	795	840	24	36 / M33
800	241	1025	540	680	220	900	136	737	760	75	3/4"	900	950	24	39 / M36
900	241	1125	600	820	220	1040	145	869	900	85	7/8"	1000	1050	28	39 / M36
1000	300	1255	710	860	220	1080	155	947	966	95	7/8"	1115	1170	28	42 / M39
1200	350	1485	750	800	220	1020	172,5	1156	1185	95	7/8"	1330	1390	32	48 / M45
1400	390	1685	935	1025	220	1245	230	1346	1370	105	1"	1530	1590	36	48 / M45
1600	440	1930				0	230					1750	1820	40	56 / M52

9 Troubleshooting

The disc does not shut tight

- Never close the disc by force. Irreparable damage may occur.
- Check if the energy supply is connected and switched on.
- Check if the actuator's closed position corresponds to the disc's closed position.
- Check the BN disc torque values using the following table (table 14).
- Check the disc's sealing surface and the elements for damage; take the disc out. Check if foreign bodies are stuck between disc and sealing elements. Remove foreign bodies or deposits if necessary.
- Replace damaged parts if necessary.

Please refer to the chapter on dismounting the disc in the maintenance appendix.

Please also refer to the chapter on "Cleaning and maintenance" in the maintenance appendix.

Fluid or gas escapes...

...from high performance butterfly valves with O-ring seals.

Check if the O-rings on the bearing sleeve are damaged. If necessary, replace the O-rings of the bearing sleeve as well as the O-ring and supporting rings of the shaft seal (see fig. 21).

Table 14 Maximum transmittable torque of the valve drive shaft in relation to the corresponding key width

Valve size [DN / inch]	Maximum transmittable torque	Shaft Ø at valve	Possible entrance Ø at actuator	Bushing required	Actuator
80 / 3"	105	20	20/25/35/40	o/x	B1J-10
100 / 4"	105	20	20/25/35/40	o/x	B1J-10
150 / 6"	158	25	20/25/35/40	o/x	B1J-10
200 / 8"	330	35	55	x	B1J-12
250 / 10"	435	35	55	x	B1J-12
300 / 12"	690	40	55	x	B1J-16
350 / 14"	833	45	55	x	B1J-16
400 / 16"	855	55	55	o	B1J-16
500 / 20"	1530	70	70	o	B1J-20
600 / 24"	2400	70	70	o	B1J-20
700 / 28"	2550	75	95	x	B1J-25
800 / 32"	4110	95	95	o	B1J-25
900 / 36"	6255	105	105	o	B1J-32
1000 / 40"	8288	105	105	o	B1J-32
1200 / 48"	15480	120	95/105/120	o	B1J-322
1400 / 56"	25050	120	95/105/120	o	B1J-322
1600 / 64"	25050	120	95/105/120	o	B1J-322

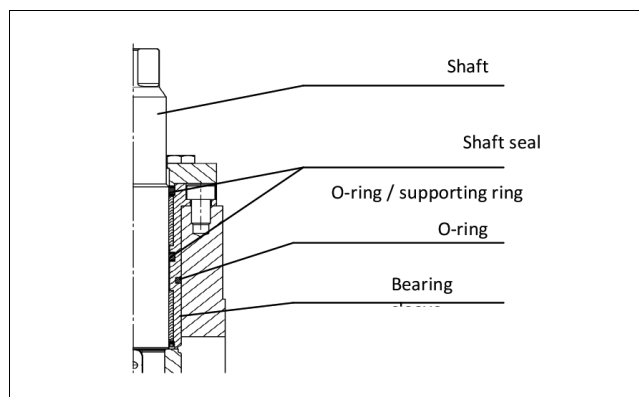


Fig. 21 O-ring seals

Fluid or gas escapes at the cover plate

Check if all cover screws are securely tightened. Replace the seal if necessary.

10 Safety instructions

Please observe the following safety instructions during installation, maintenance work and operation of the high performance butterfly valve:

1. For safety reasons, it is not permissible to make modifications to the high performance butterfly valve's mode of operation or its actuator.
2. Only qualified personnel may carry out installation work on the high performance butterfly valve.
3. During the function test the energy supply may cause the high performance butterfly valve to move in an uncontrolled fashion. Therefore please ensure that the valve cannot move or even tilt, under any circumstances, during the function test.
4. Caution is advised when installing valves with safety position "spring-to-open". If the disc protrudes from the valve in open position, the valve must be closed before installation (pneumatically, hydraulically etc.). Ensure that the energy supply is securely fastened and cannot be damaged or severed during installation under any circumstances. If the energy supply is interrupted suddenly, the valve will open abruptly. This may cause severe injuries and material damage.
5. During any maintenance work that is carried out, there is considerable risk of injury caused by accidental use of the remote control. If you plan to use a remote control during the work on the valve, an additional EMERGENCY-STOP switch is required as a locking mechanism on the actuator.
6. Ensure that cleaning agents in combination with possible deposits in the high performance valve cannot cause any undesired chemical reactions.
7. If you need to carry out work in close proximity to the sealing surface of the disc, secure the disc with wooden wedges to eliminate the risk of crushing injuries. Take care that the sealing surface of the disc is not damaged in the process.
8. If a medium that is too hot damages the seals, the medium might escape at the shafts.

10.1 Welding notes

WARNING: Welding and/or grinding stainless steel and other alloys containing chromium metal may cause the release of hexavalent chromium. Hexavalent chromium(VI) or Cr(VI), is known to cause cancer. Be sure to use all appropriate personal protective equipment (PPE) when welding metals containing chromium.

NOTE: A qualified welder must do the installation welding. The welder and welding procedure should be qualified in accordance with the ASME Boiler and Pressure Vessel Code Section IX or other applicable regulation.

CAUTION: To prevent damage to the seat and seals, do not allow the temperature of the seat and body seal area to exceed 94 °C (200 °F). It is recommended that thermal chalks be used to check the temperature in these areas during welding.

CAUTION: Ensure that any weld splatter does not fall onto the valve closing members eg. ball or seats. This may damage critical seating surfaces and cause leaks.

11 Maintenance

11.1 Cleaning and maintenance

Although Neles valves are designed to work under severe conditions, proper preventative maintenance can significantly help to prevent unplanned downtime and

in real terms reduce the total cost of ownership. Valmet recommends inspecting the valves regularly.

The inspection and maintenance interval depends on the actual application and process condition.

The inspection and maintenance intervals can be specified together with your local Valmet experts. During this periodic inspection the parts detailed in the Spare Part Set/Sets should be replaced.

Time in storage should be included in the inspection interval.

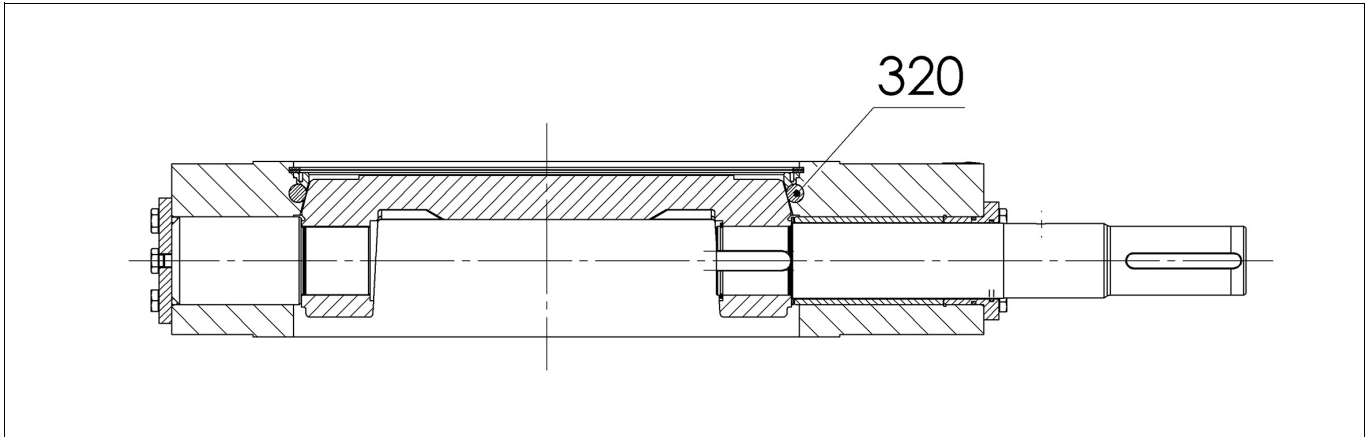


Fig. 22 Location of sealing element

If the medium carries contaminants that could impair the tightness of the valve, the sealing surfaces of the disc must be cleaned regularly. Contaminants may damage the sealing surface of the disc or the sealing element.

Agents that could corrode the sealing surface or the elastomer seal must not be used under any circumstances. Use water, soapsuds or other liquid solvents and a soft lint-free cloth.

CAUTION:

Do not under any circumstances use pointy, abrasive or sharp tools (knives, files, screwdrivers etc.). And do not use any cleaning agents that might cause undesirable chemical reactions with the residues of the medium or might attack the sealing surface or the sealing element (320).

NOTE:

When sending goods to the manufacturer for repair, do not disassemble them. Clean the valve carefully and flush the valve internals. For safety reasons, inform the manufacturer of the type of medium used in the valve (include material safety datasheets (MSDS)).

NOTE:

In order to ensure safe and effective operation, always use original spare parts to make sure that the valve functions as intended.

NOTE:

For safety reasons, replace pressure retaining bolting if the threads are damaged, have been heated, stretched or corroded.

11.2 Preparation

In order to avoid extended downtime periods during maintenance work, the appropriate spare part sets should be kept in store or ordered in time. Please take into account delivery and transport times. Before dismantling the valve, the following conditions must be met:

- Ensure that the pipelines are depressurised and free of process gases and fluids.

Check that the disc valve has cooled down or warmed up sufficiently to eliminate any risks as a result of extreme temperatures.



- Find out what was the last medium to flow through the valve. There may be residues in the valve. Ensure that there is no danger of poisoning or chemical burns when coming into contact with those residues. Use adequate protective clothing, goggles and respiratory equipment if necessary. The operators' safety instructions must be observed at all times.

If you do not dismantle the valve yourself, notify the qualified personnel of the risks and provide them with protective equipment if required. The valve must be closed during installation and dismantling in order to prevent potential damage.

11.3 Dismounting

Please see section 3.5 of this IMO for instructions on dismantling.

11.4 Reinstallation

In order to reinstall the butterfly valve, please proceed as follows:

- Close the butterfly valve.
At the end of the actuator shaft as well as the body there is a round marking. When reinstalling the valve, the two markings must be aligned.

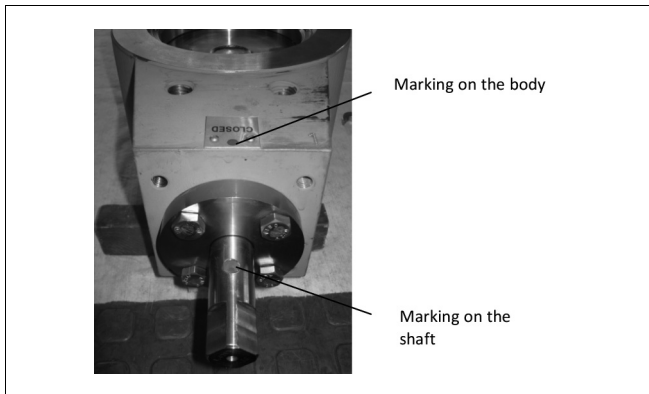


Fig. 23 Installation markings

- Set the actuator to the closed position.
- Make sure that the actuator is placed on the drive shaft in the correct position. Refer to the marking you made on the bracket and the actuator before dismantling the butterfly valve and align the markings across all elements (body – bracket – actuator) as precisely as possible.
- Install the butterfly valve between the pipe ends (see 4.3 and following chapters).

11.5 Replacing the sealing element

In order to replace the sealing element, please proceed as follows:

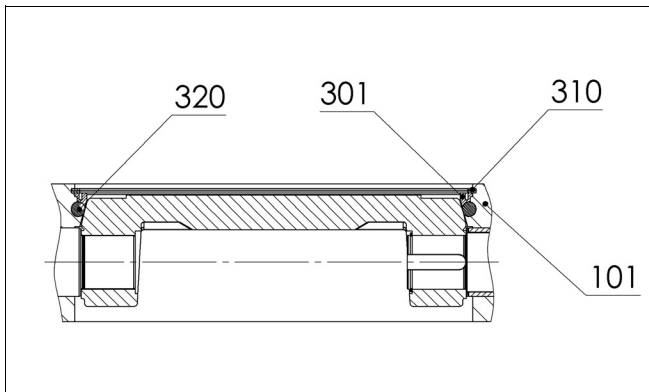


Fig. 24 Replacing the sealing element

1. Dismount the valve in the 0°-position (closed, see fig. 25) Please refer to chapter 3.5 of this IMO for instructions on dismantling the valve.
2. Place the valve securely on a solid base or workbench and ensure that it cannot slip or tilt.
3. Open the disc by turning the drive shaft counter-clockwise by 180° in order to access the sealing element (see fig. 26, disc swivelled by 180°). Secure the disc, for example using wooden wedges, to eliminate the risk of squeezing or crushing. Make sure that the sealing surface of the disc is not damaged in the process.

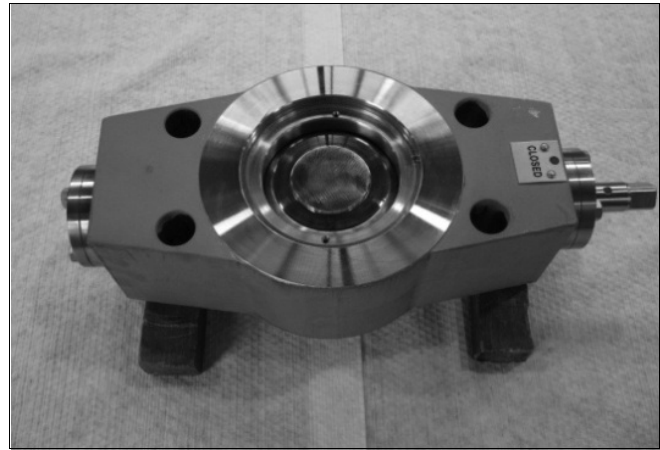


Fig. 25 Disc in 0°-position



Fig. 26 Disc swivelled by 180°

For disc size 3"-16"/DN80-400 in class CI300/PN40 and 3"/80DN in CI600/PN63

4. Remove the spiral retainer ring (310, see fig. 27 – 28). The seal ring (301) is now freely accessible and can be removed using an extraction tool (see fig. 29). For this purpose, the seal ring features two extraction threads.

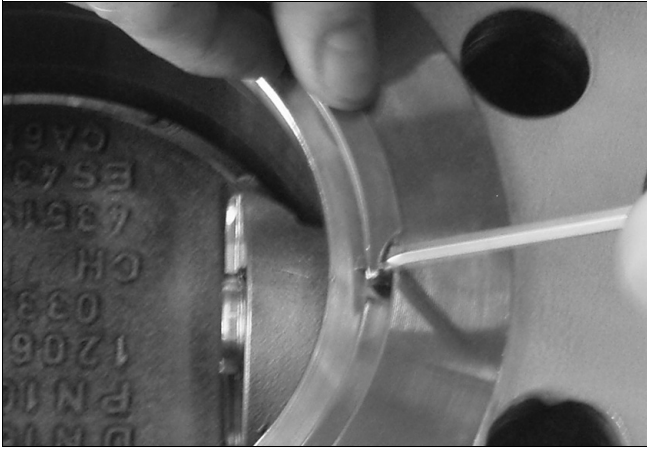


Fig. 27 Loosening the retainer ring

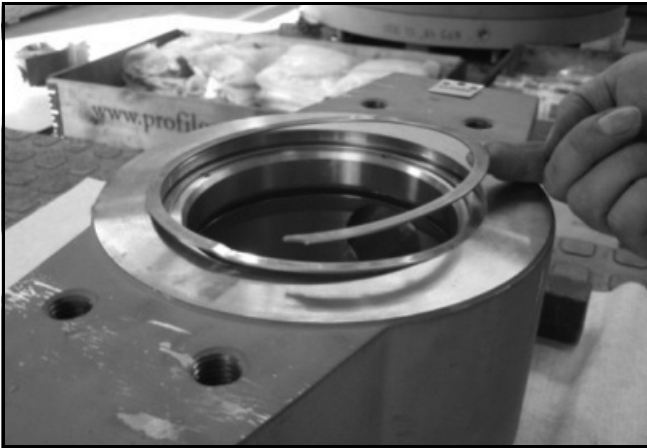


Fig. 28 Removing the retainer ring

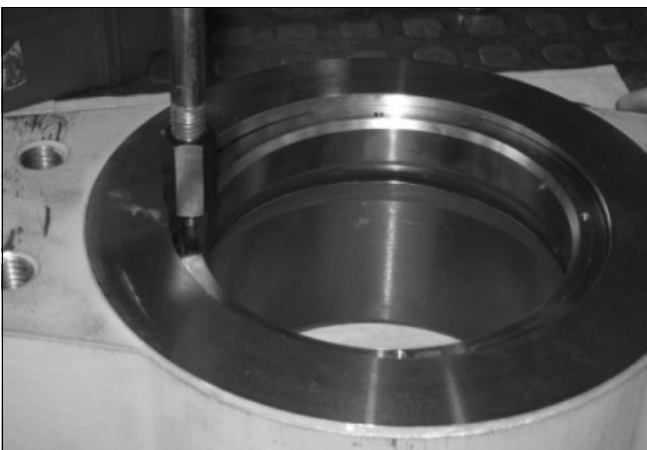


Fig. 29 Extracting the seal

5. The sealing element (320) and the O-ring seal (304) can now be replaced (see fig. 30 – 32).

Before the new seals are mounted, the sealing groove (101) and the seal ring (301) must be cleaned carefully. In order to prevent damage to the seals, care is advised when replacing the seal ring.

For disc sizes 3"-12"/DN80-300 in class CI300/PN40 and 3"/80DN in CI 600/PN63

Lastly, insert the retainer ring (310).

The retainer ring must be undamaged and free of any kinks. It must retain a clear spiral form following extraction; otherwise a new retainer ring must be used!

Ensure that the retainer ring fits snugly into the groove along its entire circumference. It must not be possible to move the retainer ring in circumferential direction manually.

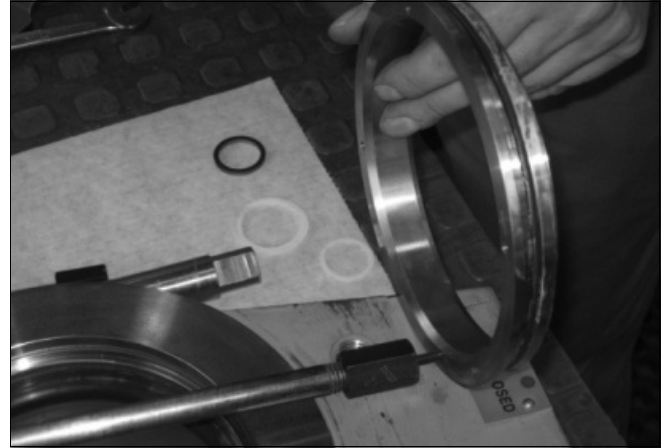


Fig. 30 Seal ring with O-ring

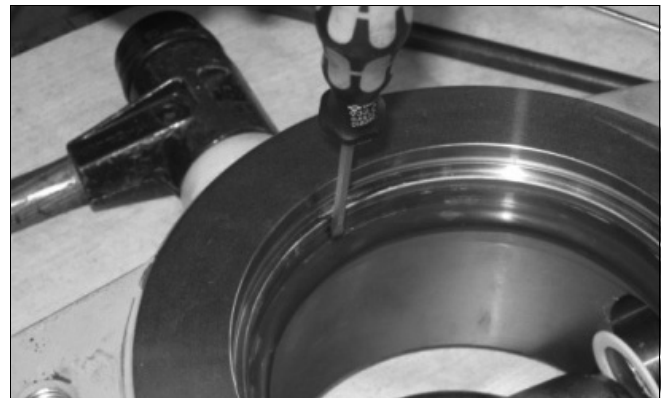


Fig. 31 Replacing the sealing element

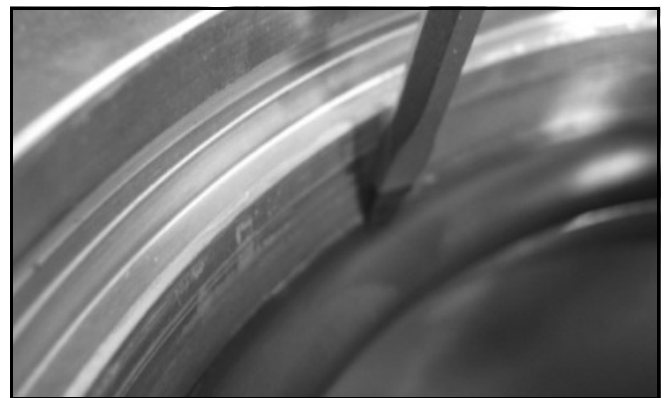


Fig. 32 Replacing the sealing element

For disc sizes 16", 20"/DN400, DN 500 in class CI300/PN40 and all sizes in CI600/PN63 except 3"/DN80

Put the retainer ring (310) and the clamping shoe (311) back in place. The retainer ring must be undamaged and free of any kinks; otherwise a new retainer ring must be used!

Lock the bolt (313) using a new locking shim and additionally with Loctite 2701 and Activator 7471 (see item 3).

Please note: Read the Loctite product instructions before use.

6. Check the high performance valve for tightness before reinstalling it. Refer to chapter 3.3 for installation instructions.

For disc sizes 20"-64"/DN500-1600 and in class CL150/PN10 to CL600/PN63

1. Dismount the valve in the 0°-position (closed, see fig. 33) Please refer to chapter 3.5 of this IMO for instructions on dismantling the valve.
2. Place the valve securely on a solid base or workbench and ensure that it cannot slip or tilt.
3. Open the disc by turning the drive shaft counter-clockwise by 180° in order to access the sealing element (see fig. 34, disc swivelled by 180°). Secure the disc, for example using wooden wedges, to eliminate the risk of squeezing or crushing. Make sure that the sealing surface of the disc is not damaged in the process.

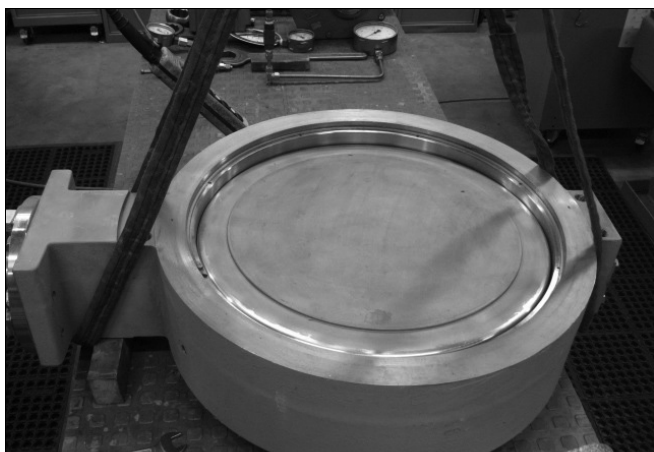


Fig. 33 Disc in 0°-position



Fig. 34 Disc in 180°-position

4. Release the clamping shoe with an open-ended or ring spanner (see fig. 35). The clamping shoe can then be extracted using a drift punch (see fig. 36).



Fig. 35 Releasing the clamping shoe



Fig. 36 Extracting the clamping shoe

5. The retainer ring (301) is now freely accessible and can be released using a drift punch (see fig. 37). Lift the retainer ring carefully from the groove (see fig. 38 and 39). Now the seal ring is free and can be lifted out. Depending on the size it might be necessary to use a hoist to lift the ring.



Fig. 37 Releasing the retainer ring using a drift punch

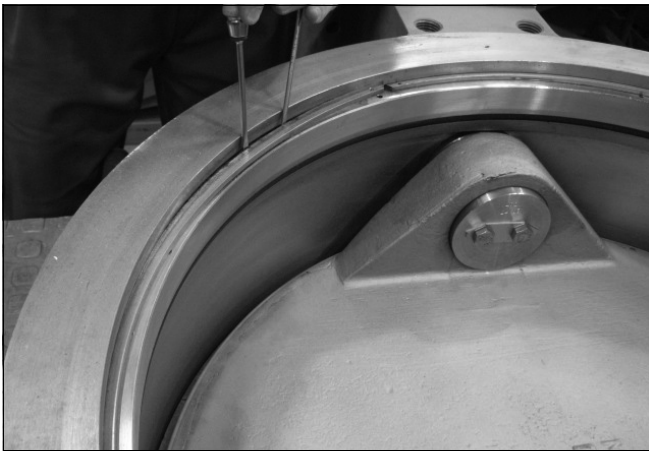


Fig. 38 Lifting the retainer ring



Fig. 39 Taking out the retainer ring



Fig. 40 Taking out the seal ring



Fig. 41 Taking out the seal ring

6. Unscrew the 4 bolts at the sealing flange (actuator shaft-side) using, for example, a 19 mm ring or open-ended spanner (fig. 42). Screw the 4 bolts into the extra holes so that the sealing flange is pressed out of its seat (see fig. 43). The clamping plate that is held in place with a locking shim and screws can now be unscrewed and taken out (see fig. 44).

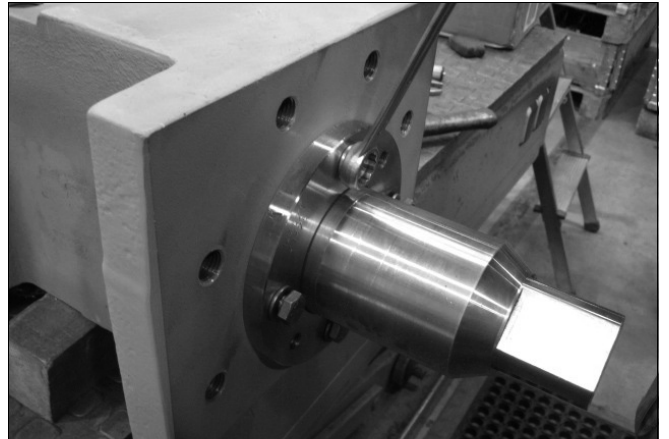


Fig. 42 Unscrewing the bolts on the sealing flange

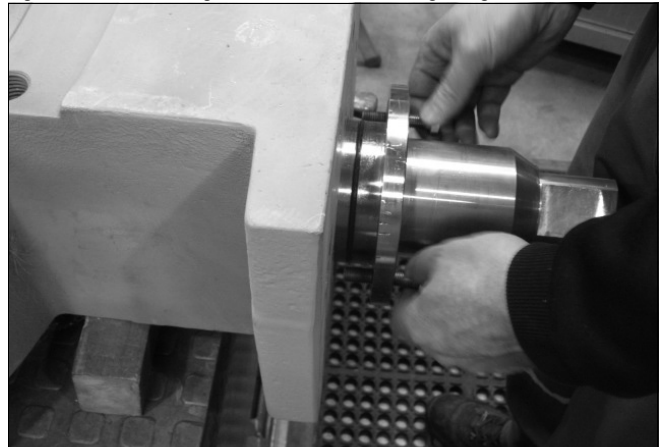


Fig. 43 Pressing out the flange



Fig. 44 Removing the clamping plate

- 7.

8. Now the bolts on the cover side of the bearing can be unscrewed and trunnion and O-ring can be removed. Pull out the shaft and the thrust ring attached to it carefully. The Metaloplast bearing on the inside can now be replaced (see fig. 45 to 49).



Fig. 45 Loosening the bolts

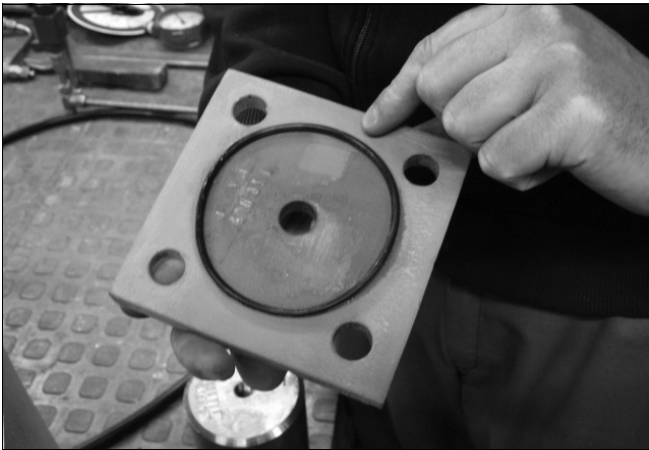


Fig. 46 Cover with O-ring



Fig. 47 Pulling out the shaft

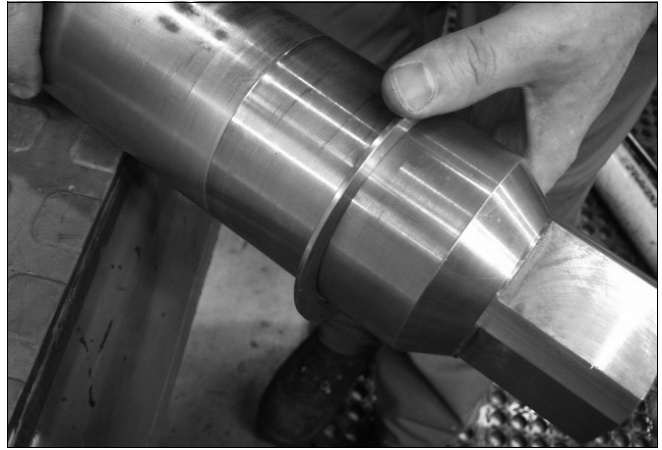


Fig. 48 Pushing the thrust ring off the shaft



Fig. 49 Replacing the Metaloplast bearing

11.6 Maximum permissible closing torque for valves without actuator at 0 bar

Table 15 Maximum permissible closing torque

Torque Mc in Nm

Pressure rating	Valve size	Closing torque
150	4" / 100	3
10		
16		
25		
150	6" / 150	5
10		
16		
25		
150	8" / 200	6
10		
16		
25		
150	10" / 250	6
10		
16		
150	12" / 300	9
10		
16		
150	14" / 350	10
10		
150	16" / 400	20
10		

Pressure rating	Valve size	Closing torque
150	20" / 500	25
10		
150	24" / 600	25
10		
150	28" / 700	30
10		
150	32" / 800	110
10		
150	36" / 900	130
10		
150	40" / 1000	130
10		
150	48" / 1200	185
10		
150	56" / 1400	200
10		
150	64" / 1600	220
10		

The torque may be diffused due to tolerances of the sealing element. The torque values apply to unlubricated sealing elements. The values must not be exceeded.

If possible, the disc should also be tested with a differential pressure into the seat.

Strongly deviating torque indicates impermissible bearing play or the sealing element not fitting correctly into the seat. Using a different sealing element might alleviate the problem in some cases.

11.7 Replacing worn parts

In order to replace worn parts, please proceed as follows (see fig. 50 to fig. 58):

1. First remove the actuator (600) and the bracket (501) by unscrewing the hexagon-head bolts (502).
2. Swivel the disc by 180° to access the sealing element. Secure the disc, for example using wooden wedges, to eliminate the risk of squeezing or crushing. Make sure that the sealing surface of the disc is not damaged in the process. In order to prevent accidental damage to the sealing element, it is recommended to follow the sequence for dismantling the sealing element described in chapter 12.5.

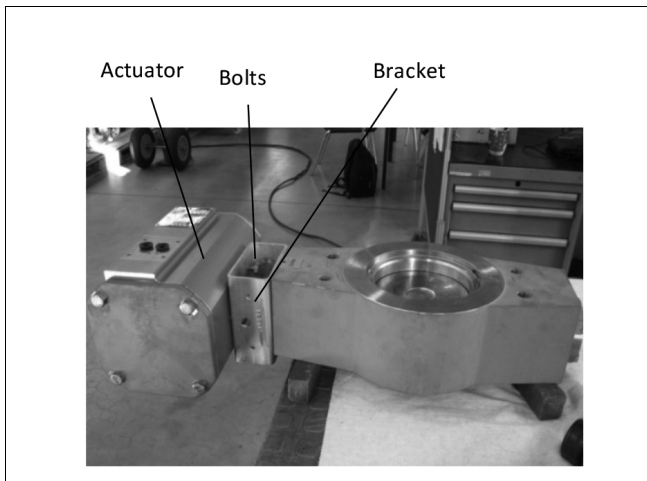


Fig. 50 Actuator – bolts – bracket



Fig. 51 Disc in 0°-position

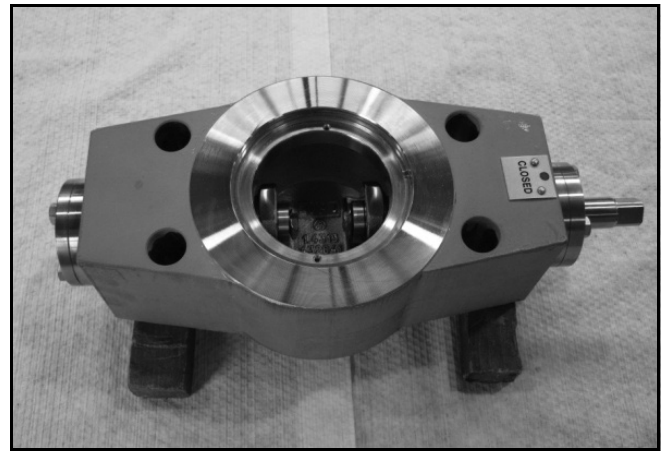


Fig. 52 Disc in 180°-position

Loosen the bolts (434) and remove the cover (430 and 437) on both sides of the valve.

Actuator side:



Fig. 53 4 bolts on the actuator side

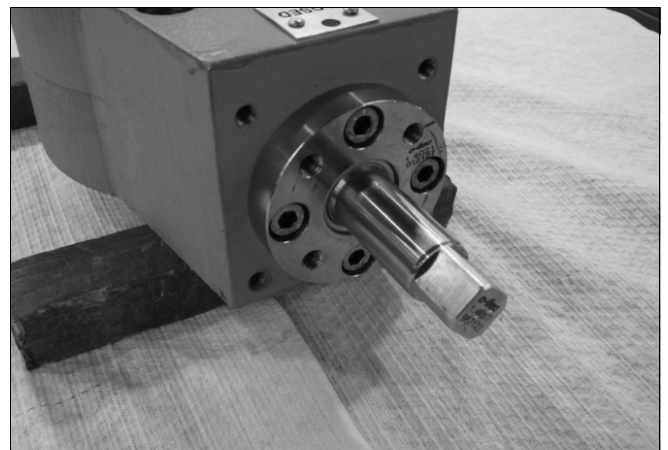


Fig. 54 Actuator side without cover

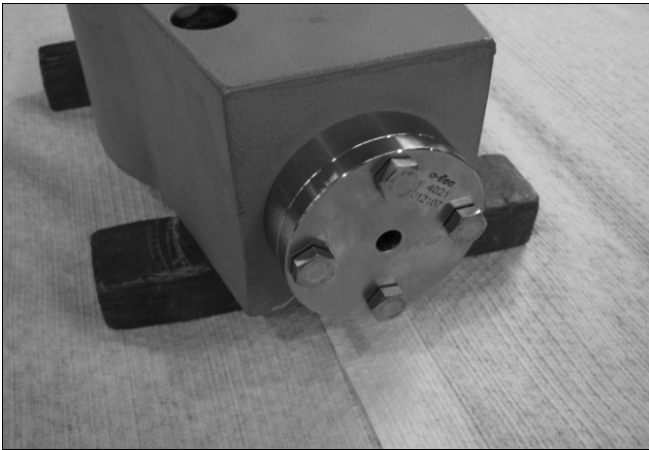
Bearing side:

Fig. 55 Cover on bearing side

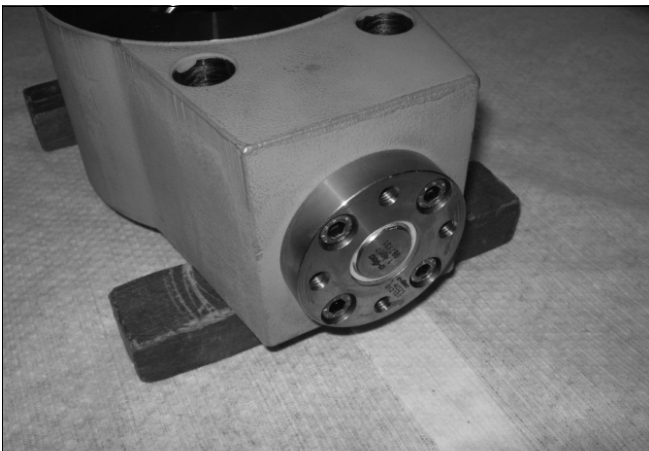


Fig. 56 Bearing side without cover

3. Insert an extraction tool into the extraction threads of the bearing sleeve and carefully pull out the bearing sleeve completely along the shaft that remains in the body.



Fig. 57 Pulling out the bearing sleeve

4. Then remove the retaining O-ring (438) and pull the shaft from the disc and the body.



Fig. 58 Pulling out the shaft

5. All parts must be cleaned thoroughly before reassembly.
6. Check the shaft for traces of wear. In case of scoring or other damage it is strongly recommended to replace the shafts (401 and 402) as well! The shafts are not included in the spare part sets and must be ordered separately.
7. Reassembly is to be carried out in reverse order. For an easier fitting of the bearing sleeve, the O-rings (419, 471) may be lubricated using a special PTFE lubricant (check suitability of lubricant in advance!). In order to prevent any damage to the seals, fit the complete bearing sleeve (410) with utmost care.
8. Fit supporting rings (406), O-rings (471) and covers (430, 437). The cover screws (434) must be tightened using a torque spanner according to the torque values specified in chapter 12.8.
9. Check the tightness of the high performance valve before reinstalling it. Please refer to chapter 3.3 for installation instructions.

The following parts can now be replaced using the recommended spare parts sets:

O-ring

Qty/ Valve	Description	Consists of
1	Spare part set 1	419, 454, 470
1	Spare part set 2a Seat set	312, 313, 320
1	Spare part set 2b Bolt set	412, 432
1	Spare part set 2c Bearing set	404, 420, 421, 422, 444, 446, 447, 448,
1	Spare part set 3	201, 301, 310, 311, 401, 403, 411, 430, 440, 453, 462*
(* not with square end at shaft)		

Packing

Qty/ Valve	Description	Consists of
1	Spare part set 1	451, 470
1	Spare part set 2a Seat set	312, 313, 320
1	Spare part set 2b Bolt set	412, 432
1	Spare part set 2c Bearing set	404, 407, 420, 421, 422, 444, 446, 447, 448, 452, 457
1	Spare part set 3	201, 301, 310, 311, 401, 403, 411, 430, 440, 450, 455, 456, 458, 462*
(* not with square end at shaft)		

11.8 Valve screws – clamping torque

Permissible clamping torque for steel group A2-70.2 and A4-70 steel group with regular metric thread in accordance with DIN 13, 70% utilisation of Rp 0.2, friction coefficient 0.16.

Table 16 Clamping torque

Ø	Stressed cross section	Stress ¹⁾ Force on shaft		Preload force N	Clamping torque Nm
	AS in mm ²	R _{p0.2} in N	R _m in N		
M4	8.8	3951	6146	2489	2.13
M5	14.2	6390	9940	4026	4.19
M6	20.1	9045	14070	5698	7.3
M8	36.6	16470	25620	10376	17.5
M10	58.0	26100	40600	16443	35.2
M12	84.3	37935	59010	23899	60.3
M14	115.0	51750	80500	32603	95.8
M16	157.0	70650	109900	44510	146.2
M18	192.0	86400	134400	54432	203.1
M20	245.0	110250	171500	69458	285.7
M22	303.0	75750	151500	47723	212.4
M24	353.0	88250	176500	55598	273.9
M27	459.0	114750	229500	72293	405.3
M30	561.0	140250	280500	85358	549.0

1) Values correspond to 100% of the 0.2% yield strength

12 Type code

Standard selection:

BN6K-300PN = WCB body & disc, PN16, FKM O-ring seal, wafer, size DN300

1	2	3	4	5	6	7	8	9
-	BN	6	K	-	300	P	N	-

1	
-	

2	Product series / design
BN	Double-eccentric, soft-sealing Neles butterfly valve

3	Body construction
3	Double flange
4	Mono flange, lug
6	Wafer
Y	Special, special body designs are specified in more detail

4	Body pressure rating
C	ASME class 150
D	ASME class 300
F	ASME class 600
J	DIN PN 10
K	DIN PN 16
L	DIN PN 25
M	DIN PN 40
N	DIN PN 63
P	DIN PN 100

5	Bearing and design
-	Soft bearing (DU-bearing)
A	Same as without code, but with ATEX earthing, ATEX II 3 G c certified valve without actuator, ATEX II 2G c certified with B-series actuator
Y	Special design, is specified in more detail

6	Size Please note: pressure rating = ASME -> inch sizes Pressure rating = DIN -> metric sizes From DN250 / 10" to DN1600 / 64" maxΔP = 10 bar
	Inch: 03, 04, 06, 08, 10, 12, 14, 16, 20, 24, 28, 32, 36, 40, 48, 56, 64 Metric: 80, 100, 150, 200, 250, 300, 350, 400, 500, 600, 700, 800, 900, 1000, 1200, 1400, 1600

7	Body & disc material
P	Body and disc: ASTM A216 gr. WCB / EN 10213- 1.0619 (doubly certified) or equivalent disc material Disc: Sealing surface of the disc stainless steel coated (AISI 304/316 or equivalent material)
P1	Body: ASTM A216 gr. WCB / EN 10213- 1.0619 (doubly certified) or equivalent material Disc: EN 10028 1.4317 / A487 gr. CA6NM (double certified) or equivalent material
A	Body: A351 gr. CF8M / EN 10213 – 1.4408 (doubly certified) or equivalent material Disc: EN 10028 1.4317 / A487 gr. CA6NM (doubly certified) or equivalent material
A1	Body: A351 gr. CF8M / EN 10213 – 1.4408 (doubly certified) or equivalent material Disc: EN 10213 – 1.4308 / A351 gr. CF8 (doubly certified) or equivalent material
Y	SPECIAL, special designs are specified in more detail

8	Seat, packing & shaft material
N	Shaft seal: FKM (VITON) Sealing element: FKM (VITON) Shaft: EN 1.4021 or equivalent T = -10 °C ... 200 °C
T	Shaft seal: PTFE packing Sealing element: Reinforced PTFE Shaft: EN 1.4313 or equivalent T = -10 °C ... 200 °C
	Shaft seal: graphite Sealing element: FKM (VITON) Shaft: EN 1.4021 or equivalent T = -10 °C ... 200 °C
Y	SPECIAL, special designs are specified in more detail

9	Face-to-face length and flange sealing surfaces For "Y" always check suitability with Neles
-	Without code, the flange sealing surfaces are suitable for the respective body pressure rating DIN standard - EN1092-1 ASME standard - ASME B 16.5 for sizes of 4" – 24" - ASME B16.47, B series #150 – 600 for sizes 26" and bigger Larger flange dimensions must be agreed with the manufacturer Please note: double flange ASME B 16.47, A series is available as "Y" code FACE-TO-FACE LENGTH DOUBLE FLANGE: For PN10/16, CI150: DIN EN 558 basic series 13 For PN25-63, CI300/600: API 609 ED6 (double flange, short pattern) Please note: gate valve face-to-face lengths for PN16 / ASME #150 available as "Y" code (according to EN 558-1 series 14) Lug, mono flange: PN10/16, CI150: DIN EN 558 basic series 16 PN25-63, CI300/600: PFIN-3105GB Wafer: PN10/16, CI150: DIN EN 558 basic series 16 PN25-63, CI300/600: PFIN-3105GB
Y	SPECIAL, special designs are specified in more detail

Valmet Flow Control Oy

Vanha Porvoontie 229, 01380 Vantaa, Finland.

Tel. +358 10 417 5000.

www.valmet.com/flowcontrol

Subject to change without prior notice.

Neles, Neles Easyflow, Jamesbury, Stonel, Valvcon and Flowrox, and certain other trademarks, are either registered trademarks or trademarks of Valmet Oyj or its subsidiaries in the United States and/or in other countries.

For more information www.neles.com/trademarks

