

Neles™ RotaryGlobe Rotary control valve Series ZX

Installation, maintenance and
operating instructions

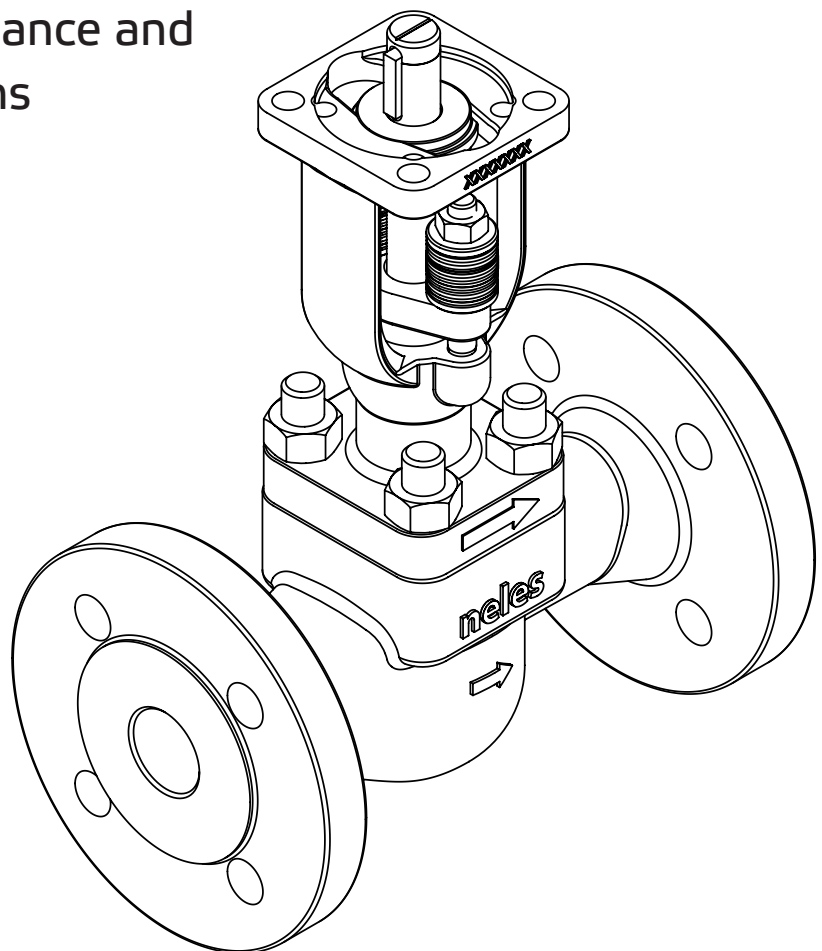

Table of contents

GENERAL	3	TOOLS	8
Scope of the manual	3	ORDERING SPARE PARTS	8
Valve construction	3	TROUBLE SHOOTING TABLE	8
Valve markings	3	EXPLODED VIEW AND PARTS LIST	9
Technical specifications	3	DIMENSIONS AND WEIGHTS	10
Valve approvals	3	EU DECLARATION OF CONFORMITY FOR ATEX APPROVED VALVES	12
CE and Atex marking	4	TYPE CODE	13
Recycling and disposal	4	GENERAL SAFETY WARNINGS AND DISCLAIMERS	14
Safety precautions	4	General safety warnings	14
Welding notes	4	General disclaimers	14
TRANSPORTATION, RECEPTION AND STORAGE	5		
VALVE INSTALLATION	5		
General	5		
Installation into the pipeline	5		
Control valve assembly	5		
Valve insulation	5		
MAINTENANCE	5		
Maintenance general	5		
Gland packing adjustment	6		
Replacing the gland packing	6		
Replacing the trim	7		
TESTING THE VALVE	7		
MOUNTING THE ACTUATOR	8		

Subject to change without notice.

All trademarks are property of their respective owners.



This product meets the requirements set by the Customs Union of the Republic of Belarus, the Republic of Kazakhstan and the Russian Federation.

READ THESE INSTRUCTIONS FIRST!

These instructions provide information about safe handling and operation of the valve.

If you require additional assistance, please contact the manufacturer or manufacturer's representative.

SAVE THESE INSTRUCTIONS!

Addresses and phone numbers are printed on the back cover.

1. GENERAL

1.1 Scope of the manual

This manual provides essential information on series ZX rotary globe valves. Actuators and positioners are only discussed briefly. Refer to the individual manuals for further information on their installation, operation and maintenance.

NOTE:

Selection and use of the valve in a specific application requires close consideration of detailed aspects. Due to the nature of the product, this manual cannot cover all the individual situations that may occur when the valve is used.

If you are uncertain about use of the valve or its suitability for your intended purpose, please contact Valmet for more information.

For valves in oxygen service, please see also the separate installation, maintenance and operating instructions for oxygen service (see Valmet document id:10O270EN.pdf)

1.2 Valve construction

Series ZX valves are flanged rotary control valves. The valve cage and plug with stem is a module accessible through the bonnet opening of the body. Fluid flows up into the cage sealed between the body and the bonnet. The plug rotates inside the cage and seals against the cage when closed, without any additional parts. The flow opening of the cage and the V-shaped plug form the desired characteristic curve of the valve when operated at 0 to 100 %. Valve closes clockwise.

The axial bearing of the stem is located outside the valve body in the yoke of the bonnet. The bearing support prevents the stem from ejecting through the pressure boundary of the valve under pressure in the event of a structural failure of the stem-to-closure member.

The detailed structure is revealed by the type code shown on the valve identification plate. The type code is explained in Section 12.

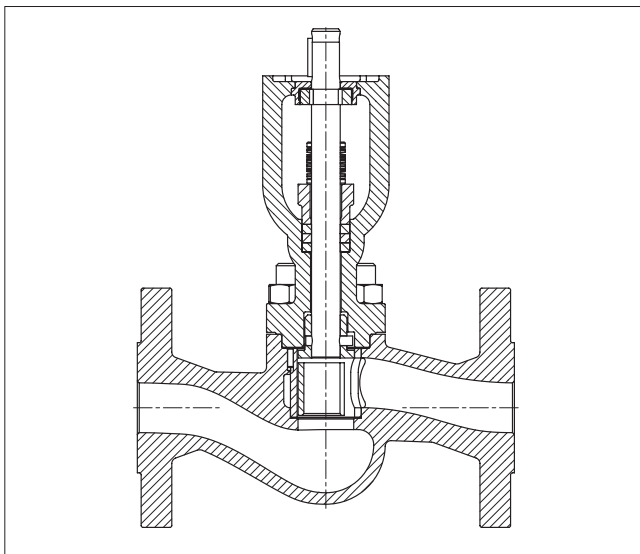

Fig. 1 Construction of a Neles RotaryGlobe

1.3 Valve markings

The body markings are: manufacturer's trademark, nominal size, pressure rating and material of the body. The valve has an identification plate attached to it, see Fig. 2.

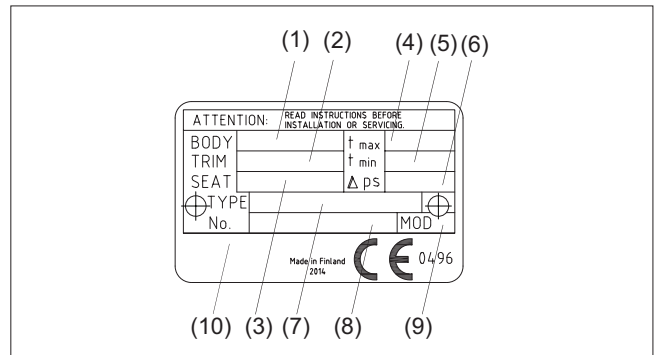

Fig. 2 Identification plate example

Markings on the identification plate:

1. Body and bonnet material
2. Trim material (plug)
3. Seat material (cage)
4. Maximum operating temperature
5. Minimum operating temperature
6. Maximum shut-off pressure differential
7. Type designation
8. Valve manufacturing parts list number
9. Model
10. Certification and approvals, eg. CE, Atex etc.

1.4 Technical specifications

Face-to-face length: ANSI/ISA-75.08.01, ANSI/ISA-75.08.06 (Long)

Body rating: Class 150 to Class 1500
PN 10 to PN 100

Max. pressure differential: acc. to pressure class

Temperature range: -80° to +425 °C

Flow direction: indicated by an arrow on the body

Actuator mounting: ISO 5211 mounting interface

Shaft connection: drive by key

Dimensions: see Section 11

Weights: see Section 11

Note that the max. shut-off pressure is based on the mechanical maximum differential pressure at ambient temperature. You must always observe the fluid temperature when deciding on applicable pressure values. When selecting a valve you must also check the noise level, cavitation intensity, flow velocity, actuator load factor, etc. using Nelprof.

1.5 Valve approvals

The valve meets the fire safety requirements of API 607/ISO 10497-5.

1.6 CE and Atex marking

The valve meets the requirements of the European Directive 2014/68/EU relating to pressure equipment, and has been marked according to the Directive.

When applicable, the valve meets the requirements of the European Directive 2014/34/EU relating to equipment and protective systems intended for use in potentially explosive atmospheres, and has been marked according to the Directive.

1.7 Recycling and disposal

Most valve parts can be recycled if sorted according to material. Most parts have a material marking. A material list is supplied with the valve. In addition, separate recycling and disposal instructions are available from the manufacturer. A valve can also be returned to the manufacturer for recycling and disposal for a fee.

1.8 Safety precautions

CAUTION:

Do not exceed the valve performance limitations!

Exceeding the limitations marked on the valve may cause damage and lead to uncontrolled pressure release. Damage or personal injury may result

CAUTION:

Do not dismantle the valve or remove it from the pipeline while the valve is pressurised!

Dismantling or removing a pressurised valve will result in uncontrolled pressure release. Always isolate the relevant part of the pipeline, release the pressure from the valve and remove the medium before dismantling the valve.

Be aware of the type of medium involved. Protect yourself and the environment from any harmful or poisonous substances. Make sure that no medium can enter the pipeline during valve maintenance.

Failure to do this may result in damage or personal injury.

CAUTION:

Beware of the plug movement!

Keep fingers, other parts of the body, tools and other objects out of the open flow port. Leave no foreign objects inside the pipeline. When the valve is actuated, the plug functions as a cutting device. Close and detach the actuator pressure supply pipeline for valve maintenance. Failure to do this may result in damage or personal injury.

CAUTION:

Protect yourself from noise!

The valve may produce noise in the pipeline. The noise level depends on the application. It can be measured or calculated using the Neles Nelprof software. Observe the relevant working environment regulations in terms of noise emission.

CAUTION:

Beware of a very cold or hot valve!

The valve body may be very cold or very hot during use. Protect yourself against cold injuries or burns.

CAUTION:

When handling the valve or the control valve assembly, take its weight into account!

Never lift the valve or control valve assembly by the positioner, the limit switch or their piping.

Place the lifting ropes securely around the valve body (see Fig. 3). Damage or personal injury may result from falling parts.

ATEX/Ex Safety

CAUTION!

The actual surface temperature of valve is depended on the process temperature. The protection from high or low temperature must be considered by the end user before valve is put into service.

CAUTION!

Ensure the general process and worker protection from static electricity in the facilities.

Note! Within series there is possibility to Category 2, Category 3 and non-ATEX valve.

CAUTION:

Potential electrostatic charging hazard. Ensure the protection in the process.

1.9 Welding notes

WARNING:

Welding and/or grinding stainless steel and other alloys containing chromium metal may cause the release of hexavalent chromium. Hexavalent chromium(VI) or Cr(VI), is known to cause cancer. Be sure to use all appropriate personal protective equipment (PPE) when welding metals containing chromium.

NOTE:

A qualified welder must do the installation welding. The welder and welding procedure should be qualified in accordance with the ASME Boiler and Pressure Vessel Code Section IX or other applicable regulation.

CAUTION:

To prevent damage to the seat and seals, do not allow the temperature of the seat and body seal area to exceed 94 °C (200 °F). It is recommended that thermal chocks be used to check the temperature in these areas during welding.

CAUTION:

Ensure that any weld splatter does not fall onto the valve closing members eg. ball or seats. This may damage critical seating surfaces and cause leaks.

2. TRANSPORTATION, RECEPTION AND STORAGE

Check the valve and the accompanying devices for any damage that may have occurred during transport.

Store the valve carefully before installation, preferably indoors in a dry place.

Do not remove the flow port protectors until immediately before installation of the valve into the pipeline.

The valve is delivered in the closed position. A valve equipped with a spring-return actuator is delivered in the position determined by the spring.

3. VALVE INSTALLATION

3.1 General

Remove the flow port protectors and check that the valve is clean inside.

CAUTION:

When handling the valve or the control valve assembly, take its weight into account!

3.2 Installation into the pipeline

Make sure no foreign particles, such as sand or pieces of welding electrode, are in the pipeline, they may damage the sealing surfaces.

The valve has an arrow indicating the flow direction. Install the valve in the pipeline so that the flow direction of the valve corresponds to the flow direction marked on the pipe. The mounting orientation of the valve does not restrict the operation of the valve, actuator or positioner. You should, however, avoid installing the valve so that the shaft points downwards as impurities in the fluid may enter and damage the gland packing. Any leak from the packing may then damage the actuator.

Choose flange gaskets according to the operating conditions.

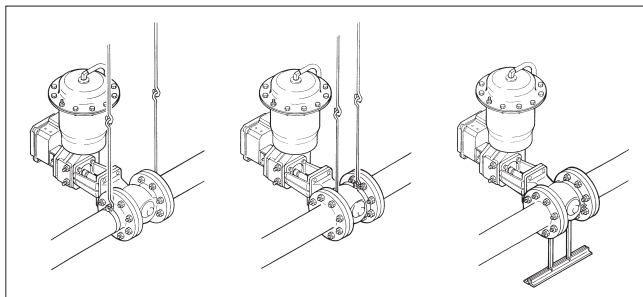

Fig. 3 Installing the control valve into pipeline using supports

Do not attempt to correct a pipeline misalignment by means of flange bolting.

Loads on the valve body from pipeline vibrations can be reduced by supporting the pipeline properly. Reduced vibration also increases the lifetime of the positioner.

Where necessary, you can support the valve by the body, using regular pipe clamps and supports. Do not fasten supports to the valve or flange bolting or to the actuator, see Fig. 3.

3.3 Control valve assembly

Check all joints, piping and cables.

Check that the actuator stop screws, positioner and limit switches are calibrated. Refer to their installation, maintenance and operating manuals.

3.4 Valve insulation

If necessary, the valve may be insulated. Insulation must not continue above the upper level of the valve body, see Figure 4.

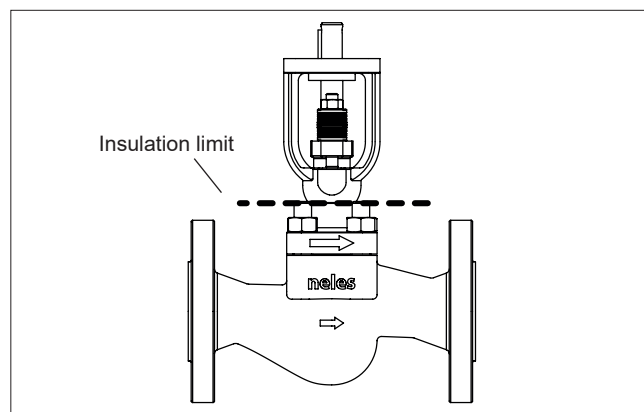

Fig. 4 Insulation of the valve

4. MAINTENANCE

CAUTION:

Observe the safety precautions mentioned in Section 1.8 before maintenance!

CAUTION:

When handling the valve or the valve package as a whole, bear in mind the weight of the valve or the entire package.

4.1 Maintenance general

Although Neles valves are designed to work under severe conditions, proper preventative maintenance can significantly help to prevent unplanned downtime and in real terms reduce the total cost of ownership. Valmet recommends inspecting the valves at least every five (5) years. The inspection and maintenance interval depends on the actual application and process condition.

The inspection and maintenance intervals can be specified together with your local Valmet experts. During this periodic inspection the parts detailed in the Spare Part Set should be replaced. Time in storage should be included in the inspection interval.

Maintenance can be performed as presented below. For maintenance assistance, please contact your local Valmet office. The part numbers in the text refer to the exploded view and to the parts list in Section 10, unless otherwise stated.

NOTE:

When sending goods to the manufacturer for repair, do not disassemble them. Clean the valve carefully and flush the valve internals. For safety reasons, inform the manufacturer of the type of medium used in the valve (include material safety datasheets (MSDS)).

NOTE:

In order to ensure safe and effective operation, always use original spare parts to make sure that the valve functions as intended.

NOTE:

For safety reasons, replace pressure retaining bolting if the threads are damaged, have been heated, stretched or corroded.

A practical way to check the condition of the thread: Try to rotate a new, unused nut with a thread. The condition of the thread is good if the nut rotates smoothly and does not get stuck.

4.2 Gland packing adjustment

In the event of a packing leakage tighten the gland nuts (18) in ¼ turn steps each until the leakage is stopped. Do not tighten more than necessary.

4.3 Replacing the gland packing

CAUTION:

Do not dismantle the valve or remove it from the pipeline while the valve is pressurised!

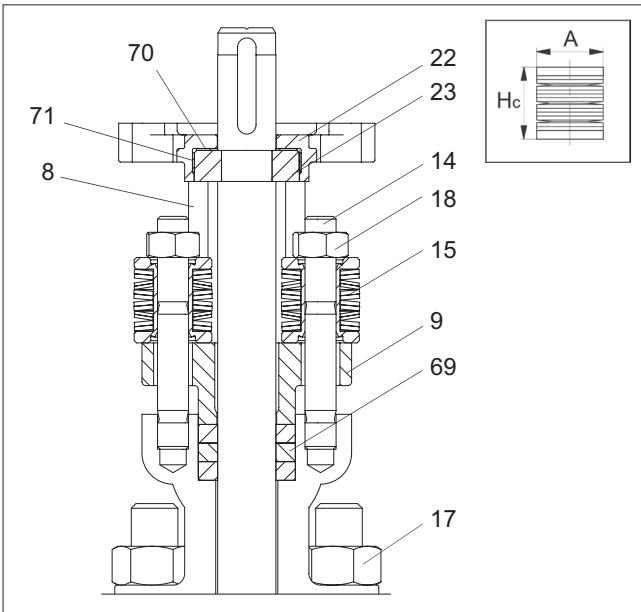

Fig. 5 Gland packing

- Make sure the valve is not pressurised.
- Remove the actuator from the valve shaft according to the instructions given in the actuator manual.

- Remove the key (10) from the drive shaft (5) and gland nuts (18) with the optional spring package
- Remove the hexagon nuts (17) and lift the bonnet (8) with the shaft and plug (3) out of the body.
- Push the shaft until the thrust bearing (22) can be released from the groove of the shaft by lifting the support ring (23).
- Slide the support ring, sheet ring (70) and gland (9) away from the shaft.
- Draw the shaft out of the bonnet.
- Remove the old packing rings (69) using a pointed tool. Avoid damaging the sealing surfaces.
- Clean the packing ring counterbore.
- Mount the new packing rings one by one to the bore using the gland as a tool and mount the gland with hand-tightened nuts.
- Push the shaft through the bonnet halfway to the yoke, and check the keyway edges not to scratch the packing rings.
- Mount the sheet ring (70) and support ring (23) with the bearing strip (71) on the shaft. Mount the net side of the sheet ring and bearing strip against the thrust bearing. Hold the thrust bearing halves onto the groove of the shaft and slide the support ring onto the thrust bearing to lock it. Push the shaft into the upper position. Make sure the pin (6) head of the plug is in the recess of the bonnet.
- Fasten the gland with the nuts (18) and tighten them so that the disc springs are compressed to the height Hc, or with torque Tt if valve doesn't have them. Values in Table 1.

Table 1

Valve size	Pressure class	Shaft dia	Disc spring Dia	Disc Spring	Nut
		mm	A, mm	Hc, mm	Tt, Nm
1/2"-01"	ASME150-600, PN40-100	15	20	22.6	5
01"	ASME1500	20	20	22.3	11
1,5"-02"	ASME150-600, PN40-100	20	20	22.3	7
1,5"-02"	ASME1500	25	31.5	32.6	15
03"	ASME150-300, PN40	30	25	31.4	15
03"	ASME600, PN100	30	31.5	32.2	17
03"	ASME900-1500	40	35.5	41.6	25
04"	ASME150-300, PN40	40	25	31.4	26
04"	ASME600, PN100	40	35.5	41.6	25
04"	ASME900-1500	50	40	45.1	50

- Remove the old bonnet seal (66) from the body, clean the surfaces and install the new seal.
- **Make sure the pin (21) is in the hole between the cage (7) and the body before mounting the bonnet seal.** Mount the bonnet with the shaft and plug onto the body with the plug in the closed position, so that the arrows on the body and on the bonnet point in the same direction. Tighten the nuts (17) in a crosswise pattern according to Table 2.

Table 2 Screw torques, Nm (for lubricated screws)

Screw	M8	M10	M12	M14	M16	M18	M20	M30	M36
L7M	25	50	85	140	210	290	420	1400	2500
B8M cl.1	11	22	38	61	95	130	190	650	1100

- Tap the key (10) to the keyway.
- Check leakage when the valve is pressurised.

4.4 Replacing the trim

NOTE:

The trim set consists of the cage, pin, plug with shaft and seals. Do not mix the cage or plug between sets.

- Make sure the valve is not pressurised.
- Remove the actuator from the valve shaft according to the instructions given in the actuator manual.
- Remove the key (10) from the drive shaft (5) and gland nuts (18) with the optional spring package (15).
- Remove the bonnet nuts (17) and lift the bonnet (8) with the shaft and plug out of the body.
- Push the shaft until the thrust bearing (22) can be released from the groove of the shaft by lifting the support ring (23).
- Slide the support ring, sheet ring (70) and gland (9) away from the shaft.
- Draw the shaft out of the bonnet.
- Remove the cage (7) using the removal tool as in Figure 6, where necessary.

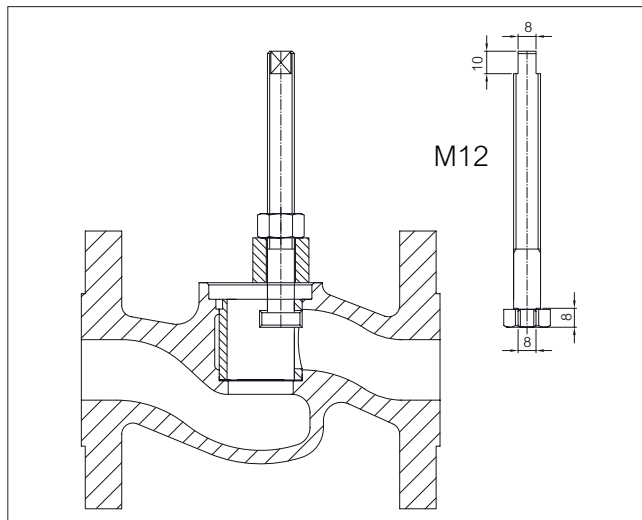

Fig. 6 Cage removal tool

- Remove the old cage seal ring (67) from the bottom of the body cavity and remains of the bonnet seal (66). Do not scratch the sealing surfaces.
- Clean the cage cavity of the body.
- Mount the new cage seal to the bottom of the cage cavity of the body.
- Mount the cage into the body so the pin hole sections are aligned.
- Mount the pin (21) into the hole, make sure the top is not above the bonnet seal surface.
- **Make sure the pin (21) is in the hole between the cage (7) and the body before mounting the bonnet seal.** Mount the new bonnet seal.
- Push the shaft through the bonnet halfway to the yoke and check the keyway edges so as not to scratch the packing rings.

- Mount the sheet ring (70) and support ring (23) with the bearing strip (71) on the shaft. Mount the net side of the sheet ring and bearing strip against the thrust bearing. Hold the thrust bearing halves onto the groove of the shaft and slide the support ring onto the thrust bearing to lock it. Push the shaft to the upper position. Make sure the pin (6) head of the plug is in the recess of the bonnet.
- Fasten the gland (9) with the nuts (18) and tighten them so that the disc springs are compressed to the height H_c , or with torque T_t if valve doesn't have them. Values in Table 1.
- Mount the bonnet with the shaft and plug to the body, plug in closed position, so the arrows on the body and on the bonnet point to the same direction. Tighten the nuts (17) in a cross-tightening manner according to the Table 2.
- Tap the key (10) to the keyway.

Other parts

- Clean all parts carefully, including the studs and nuts.
- After cleaning and checking all parts, keep them in a protected place until reassembly. Handle the ball, its seats and the body joint surfaces with particular care.
- If necessary, send the valve to the manufacturer for repairs.
- Check the shaft (5) and thrust bearings (22). If the shaft is worn in the packing area, it can be repaired by machining, but the diameter must be no less than given in below. If less, replace the shaft with new one. **Note!** Machining the shaft to smaller diameter is not allowed if the valve has been delivered as ISO 15848 type approved (fugitive emission). Do not repair worn shaft by welding.

Shaft nominal diameter $\varnothing A$ [mm]	Tolerance for remachining [mm]
15 - 80	0/-0.1
85 - 200	0/-0.2

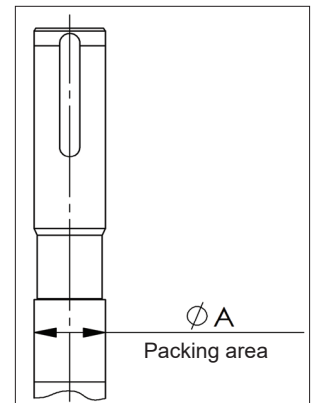

5. TESTING THE VALVE

CAUTION:

Pressure testing should be carried out using equipment conforming to the correct pressure class!

We recommend that the valve body is pressure-tested after the valve has been assembled.

The pressure test should be carried out in accordance with an applicable standard for the pressure rating. The valve must be in the open position during the test.

6. MOUNTING THE ACTUATOR

The actuator is attached to the valve via an ISO 5211 standard mounting interface. Several types of Neles actuators can be used with suitable couplings. Refer to the individual manuals for further information on their installation, maintenance and operation.

CAUTION:

Beware of the plug movement!

- Push the actuator carefully onto the valve shaft. Avoid forcing it, since this may damage the plug and cage. Tighten the screws of the interface, see Table 2.
- The cone coupling has an axial tightening screw in E-series actuators. Make sure it is tightened according to the instructions.

NOTE:

The B1J actuator (spring-to-close) may not be driven against the internal stop screw with the full spring torque. Adjust the limit by lowering the actuator pressure slowly. The counterpressure in the actuator limits the spring torque. Operate the B1JA (spring-to-open) actuator, or the double-acting B1C actuator with the lowest possible pressure against the internal stop. Excessive torque may damage the valve.

- Adjust the closed position of the trim by means of the actuator stop screw, see actuator instructions. The valve has an internal limit stop to find the closed position of the valve. Unscrew the closed position stop screw of the actuator until the rotation of the valve shaft stops or if the valve shaft does not rotate turn in the opposite direction until the shaft starts to rotate. Then adjust the stop screw by one half turn so the valve rotates in the open direction slightly. Lock the stop screw.
- Adjust the open position of the trim by means of the actuator stop screw. Drive the actuator 90 degrees from the closed position. Turn the stop screw to the contact and lock the stop screw.
- The stop screw threads through the cylinder heads of the actuator must be sealed using an appropriate non-hardening sealant, e.g. Loctite 225.

9. TROUBLE SHOOTING TABLE

The following Table 4 lists malfunctions that might occur after prolonged use.

Table 4 Trouble shooting

Symptom	Possible fault	Recommended action
Leakage through a closed valve	Wrong stop screw adjustment of the actuator	Adjust the stop screw for closed position
	Faulty zero setting of the positioner	Adjust the positioner
	Damaged seat	Replace seat
	Damaged closing member	Replace the closing member
Leakage through body joint	Closing member in a wrong position relative to the actuator	Select the correct keyway in the actuator
	Damaged gasket	Replace the gasket
Irregular valve movements	Loose body joint	Tighten the nuts or screws
	Actuator or positioner malfunction	Check the operation of the actuator and positioner
	Process medium accumulated on the sealing surface	Clean the sealing surfaces
	Closing member or seat damaged	Replace the closing member or seat
Gland packing leaking	Crystallizing medium has entered the bearing spaces	Flush the bearing spaces
	Gland packing worn or damaged	Replace the gland packing
	Loose packing	Tighten the packing nuts

7. TOOLS

Removal of the actuator

In addition to standard tools, the following special tools might facilitate some phases of the work.

- Extractor. (ID-code table in actuator's IMO)
- cage removal tool, see Table 3.

Table 3 Cage removal tools series ZX

Product:	ID:
DN 0H-02 (12 mm - 50 mm)	H083121
DN 03 (80 mm)	H137439
DN 04 (100 mm)	H137435

Tools can be ordered from the manufacturer.

8. ORDERING SPARE PARTS

NOTE:

Always use original spare parts to make sure that the valve functions as intended.

When ordering spare parts, always include the following information:

- type code, sales order number, serial number
- number of the parts list, part number, name of the part and quantity required

This information can be found from the identification plate or documents.

10. EXPLODED VIEW AND PARTS LIST

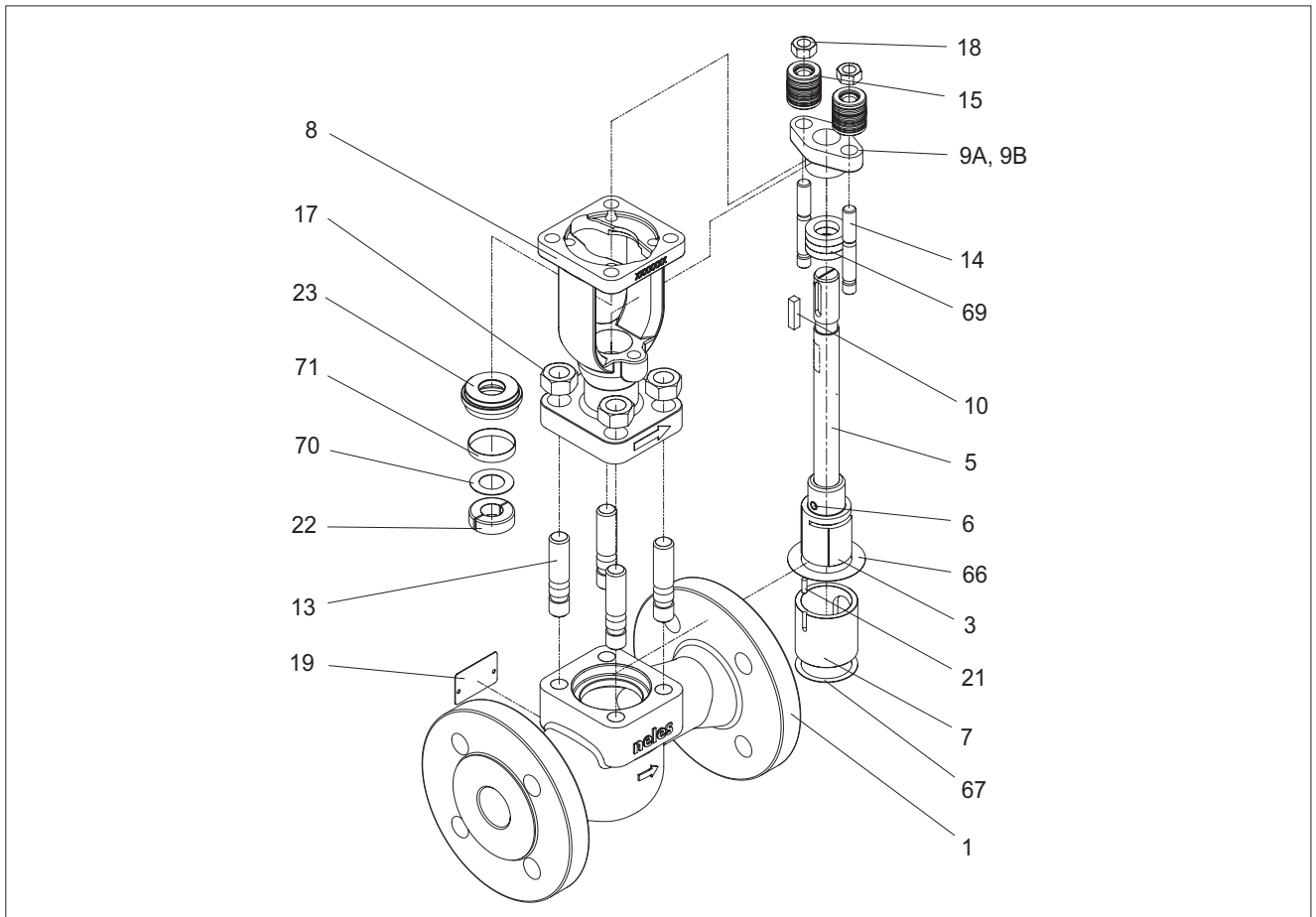

Item	Qty.	Description	Recommended spare part
1	1	Body	
3 *)	1	Plug	
5 *)	1	Shaft	
6 *)	1	Pin	
7	1	Valve cage	
8	1	Bonnet	
9A	1	Gland	
9B	1	Compression sleeve **)	
10	1	Key	
13	4	Stud	
14	2	Stud	
15	2	Disc spring set	
17	4	Hexagon nut	
18	2	Hexagon nut	
19	1	Identification plate	
21	1	Pin	X
22	2	Thrust bearing	
23	1	Support ring	
66	1	Sheet ring	X
67	1	Sheet ring	X
69	1	V-ring set	X
70	1	Sheet ring	X
71	1	Bearing strip	X

*) delivered as a set

***) sizes 3" and 4" only

11. DIMENSIONS AND WEIGHTS

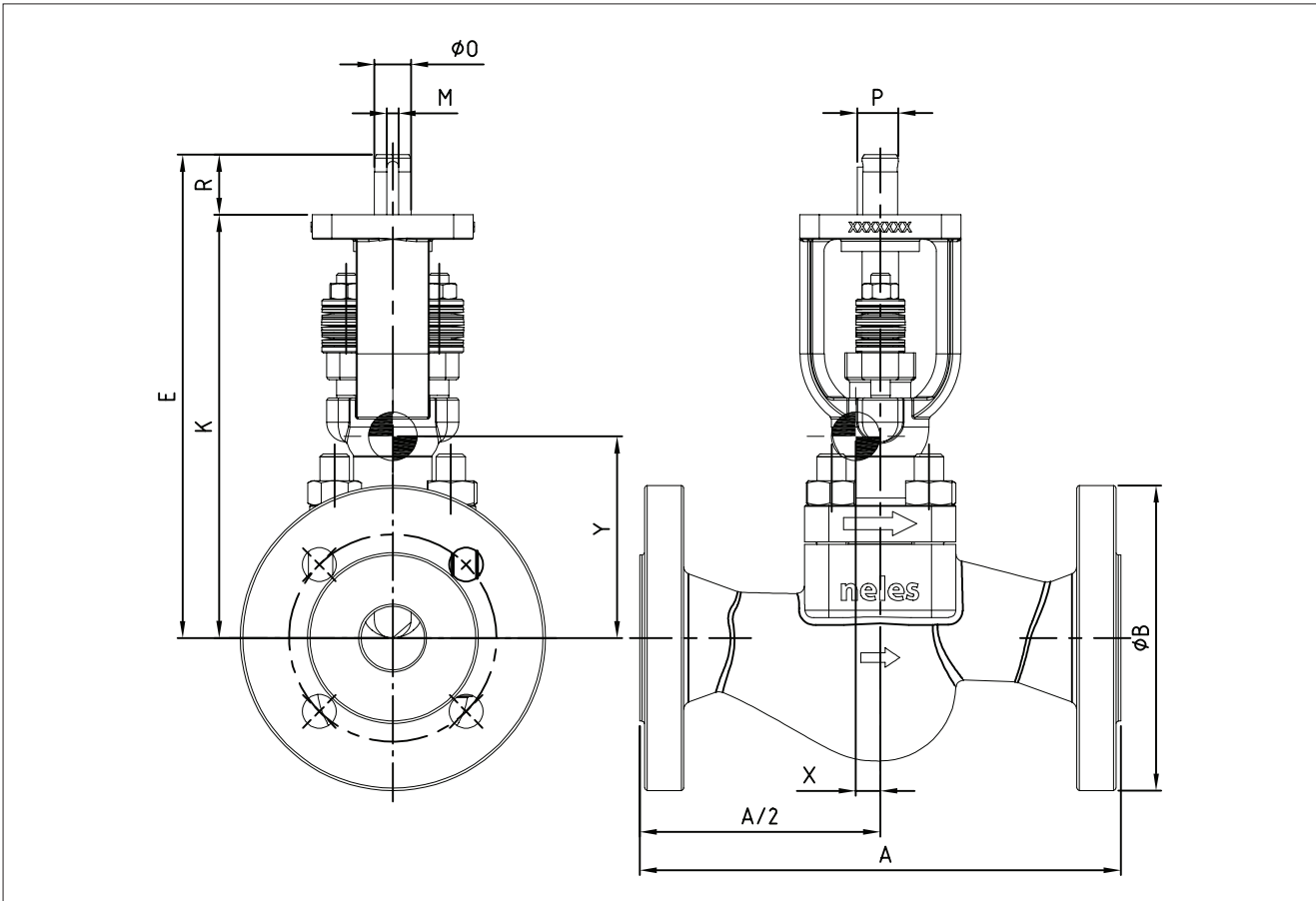

Class 150

TYPE	SIZE	ISO FLANGE	DIMENSIONS, mm (inch)								kg (lbs)
			A	ϕB	E	K	M	ϕO	P	R	
ZXC	1/2	F05, F07	184 (7.24)	90 (3.54)	199 (7.83)	174 (6.85)	4.76 (0.19)	15 (0.59)	17 (0.67)	25 (0.98)	4.6 (10.1)
	3/4	F05, F07	184 (7.24)	100 (3.94)	199 (7.83)	174 (6.85)	4.76 (0.19)	15 (0.59)	17 (0.67)	25 (0.98)	5.0 (11.0)
	1	F05, F07	184 (7.24)	110 (4.33)	199 (7.83)	174 (6.85)	4.76 (0.19)	15 (0.59)	17 (0.67)	25 (0.98)	5.4 (11.9)
	1 1/2	F07, F10	222 (8.74)	125 (4.92)	236 (9.29)	201 (7.91)	4.76 (0.19)	20 (0.79)	22.2 (0.87)	35 (1.38)	11.2 (24.7)
	2	F07, F10	254 (10.00)	150 (5.91)	236 (9.29)	201 (7.91)	4.76 (0.19)	20 (0.79)	22.2 (0.87)	35 (1.38)	13.2 (29.2)
	3	F10, F12	298 (11.73)	190 (7.48)	382 (15.03)	331 (13.02)	6.35 (0.25)	30 (1.18)	32.85 (1.29)	51 (2.01)	27.7 (60.8)
4	F12, F14	352 (13.85)	230 (9.05)	436 (17.16)	368 (14.48)	9.53 (0.37)	40 (1.57)	44.2 (1.74)	68 (2.68)	60.7 (133.3)	

Class 300

TYPE	SIZE	ISO FLANGE	DIMENSIONS, mm (inch)								kg (lbs)
			A	ϕB	E	K	M	ϕO	P	R	
ZXD ZXM	1/2	F05, F07	190 (7.48)	95 (3.74)	199 (7.83)	174 (6.85)	4.76 (0.19)	15 (0.59)	17 (0.67)	25 (0.98)	5.6 (12.3)
	3/4	F05, F07	194 (7.64)	115 (4.53)	199 (7.83)	174 (6.85)	4.76 (0.19)	15 (0.59)	17 (0.67)	25 (0.98)	7.5 (16.5)
	1	F05, F07	197 (7.76)	125 (4.92)	199 (7.83)	174 (6.85)	4.76 (0.19)	15 (0.59)	17 (0.67)	25 (0.98)	7.5 (16.5)
	1 1/2	F07, F10	235 (9.25)	155 (6.10)	236 (9.29)	201 (7.91)	4.76 (0.19)	20 (0.79)	22.2 (0.87)	35 (1.38)	15.3 (33.7)
	2	F07, F10	267 (10.51)	165 (6.50)	236 (9.29)	201 (7.91)	4.76 (0.19)	20 (0.79)	22.2 (0.87)	35 (1.38)	16.9 (37.2)
	3	F10, F12	316 (12.43)	210 (8.26)	382 (15.03)	331 (13.02)	6.35 (0.25)	30 (1.18)	32.85 (1.29)	51 (2.01)	32.6 (71.6)
4	F12, F14	368.2 (14.49)	255 (10.03)	436 (17.16)	368 (14.48)	9.53 (0.37)	40 (1.57)	44.2 (1.74)	68 (2.68)	68.7 (150.8)	

Class 600

TYPE	SIZE	ISO FLANGE	DIMENSIONS, mm (inch)								kg (lbs)
			A	ØB	E	K	M	ØO	P	R	
ZXD ZXM ZXP	1/2	F05, F07	203 (7.99)	95 (3.74)	199 (7.83)	174 (6.85)	4.76 (0.19)	15 (0.59)	17 (0.67)	25 (0.98)	5.7 (12.6)
	3/4	F05, F07	206 (8.11)	115 (4.53)	199 (7.83)	174 (6.85)	4.76 (0.19)	15 (0.59)	17 (0.67)	25 (0.98)	6.7 (14.8)
	1	F05, F07	210 (8.27)	125 (4.92)	199 (7.83)	174 (6.85)	4.76 (0.19)	15 (0.59)	17 (0.67)	25 (0.98)	7.6 (16.7)
	1 1/2	F07, F10	251 (9.88)	155 (6.10)	236 (9.29)	201 (7.91)	4.76 (0.19)	20 (0.79)	22.2 (0.87)	35 (1.38)	15.8 (34.8)
	2	F07, F10	286 (11.26)	165 (6.50)	236 (9.29)	201 (7.91)	4.76 (0.19)	20 (0.79)	22.2 (0.87)	35 (1.38)	18.0 (39.7)
	3	F10, F12	337 (13.26)	210 (8.26)	382 (15.03)	331 (13.02)	6.35 (0.25)	30 (1.18)	32.85 (1.29)	51 (2.01)	41.6 (91.3)
4	F12, F14	394 (15.5)	275 (10.82)	436 (17.16)	368 (14.48)	9.53 (0.37)	40 (1.57)	44.2 (1.74)	68 (2.68)	75.2 (165.1)	

Class 900

TYPE	SIZE	ISO FLANGE	DIMENSIONS, mm (inch)								kg (lbs)
			A	ØB	E	K	M	ØO	P	R	
ZXG	3	F12, F14	441 (17.36)	240 (9.45)	473 (18.62)	405 (15.94)	9.53 (0.38)	40 (1.57)	44.2 (1.74)	68 (2.68)	93.9 (207.0)
	4	F14, F16	511 (20.12)	290 (11.42)	567 (22.32)	477 (18.78)	12.70 (0.50)	50 (1.97)	55.4 (2.18)	90 (3.54)	159.6 (351.9)

Class 1500

TYPE	SIZE	ISO FLANGE	DIMENSIONS, mm (inch)								kg (lbs)
			A	ØB	E	K	M	ØO	P	R	
ZXH	1	F07, F10	292 (11.50)	150 (5.91)	264 (10.39)	229 (9.02)	4.76 (0.19)	20 (0.79)	22.2 (0.87)	35 (1.38)	23.5 (51.8)
	1 1/2	F10, F12	333 (13.11)	180 (7.09)	373 (14.69)	327 (12.87)	6.35 (0.25)	25 (0.98)	27.8 (1.09)	46 (1.81)	38.0 (83.7)
	2	F10, F12	375 (14.76)	215 (8.46)	373 (14.69)	327 (12.87)	6.35 (0.25)	25 (0.98)	27.8 (1.09)	46 (1.81)	49.2 (108.4)
	3	F12, F14	460 (18.11)	265 (10.43)	473 (18.62)	405 (15.94)	9.53 (0.38)	40 (1.57)	44.2 (1.74)	68 (2.68)	104.9 (231.3)
	4	F14, F16	530 (20.87)	310 (12.20)	567 (22.32)	477 (18.78)	12.70 (0.50)	50 (1.97)	55.4 (2.18)	90 (3.54)	174.1 (108.5)

Size	ZXC		ZXD/M		ZXF/N/P		ZXG	
	X	Y	X	Y	X	Y	X	Y
3	-0.8	92.4	-0.7	79.9	-0.4	72.3	-1.3	97.5
4	-1.3	99.4	-1.1	88.2	-1.0	77.1	-2.0	113.4

Size	ZXH	
	X	Y
1	-0.7	45.7
1 1/2	-0.6	74.8
2	-0.7	59.9
3	-1.15	87.9
4	-1.8	104.5

NOTE:

Center of mass values are approximate based on 3D-models. Please be aware the actual values may vary due to manufacturing tolerances.

12. EU DECLARATION OF CONFORMITY FOR ATEX APPROVED VALVES



EU DECLARATION OF CONFORMITY for ATEX approved valves

Manufacturer:
Valmet Flow Control Oy
01380 Vantaa, Finland



EU Authorised Representative: Valmet Flow Control Oy, Vanha Porvoontie 229, 01380 Vantaa, Finland. Contact details: [+358 10 417 5000](tel:+358104175000)

This declaration of conformity is issued under the sole responsibility of the manufacturer.

Product:	Neles RotaryGlobe valves	
Type:	Z-series (ZX)	
ATEX group and category:	II 2 GD, II 3 GD	
Ex GAS:	Ex h IIC 85°C...Tmax Gb	
Ex DUST:	Ex h IIIC T85°C...T(Tmax) Db	
Tmax= valve max. temperature in name plate		

Manufacturer's certificates:

Standard / Directive	Notified Body and NoBo number	Certificate No.
ISO 9001:2015	LRQA (Certification body)	00029133 (Approval No.)
PED 2014/68/EU Module H	DNV Business Assurance Italy S.r.l. 0496	142306-2013-CE-FIN-ACCREDIA
ATEX 2014/34/EU Annex IV	DNV Product Assurance AS Norway 2460	Presafe 18 ATEX 91983Q Issue 6

ATEX 2014/34/EU Annex VIII technical files are archived by Notified Body number 0537

The object of the declaration described above is in conformity with the relevant Union harmonisation legislation:

PED 2014/68/EU	Valve
ATEX 2014/34/EU	Non-electrical equipment

Main components:

Valve: The valve is suitable for service up to PED Cat III Valve design standard: ASME B16.34

Installation, Maintenance and Operating instructions manual (IMO) must be followed before installation in order to ensure proper and safe mounting and usage of equipment.

The product above is manufactured in compliance with the applicable European directives and technical specifications/standards (EN10204). The product is in conformity with the customer order.

Instrumentation and accessories having equal protection concept, level and performance specification with the original can be presumed to be in conformity with this Declaration of Conformity.

Protection from e.g. static electricity caused by the process or connected equipment must be considered by the user (EN 60079-14 § 6). EN 60079-19 applies for modifications.

Non-electrical equipment is according EN 80079-37:2016 and EN 80079-36:2016. The actual surface temperature of non-electrical equipment is depended on the process and ambient conditions (EN 80079-36:2016 § 6.2.5 and 6.2.7). The protection from high or low temperature must be considered by the end user before put into service.

The product does not possess any residual risk according to hazard analysis conducted under the applicable directives providing that the procedures stated by the IMO are followed and the product is used under conditions mentioned in the technical specifications.

Documents with digital and/or e-signature conveyed by Valmet Flow Control conform to the Regulation (EU) No 910/2014 as well as the national code on e-signatures. In order to secure the integrity of the document, the authenticity of the sender, and indisputableness of the dispatch the identification is covered by individual ID codes, passwords, and by regularly changing passwords. The authorization to sign documents is based on organizational position and/or is task related. The impartial third party in the company bestows the access right with predefined authorities to particular databases.

Vantaa 1.10.2025

Matti Rousku, Quality Director

13. TYPE CODE

Neles™ RotaryGlobe Control Valve, Series ZX						
1.	2.	3.	4.	5.	6.	7.
ZX	D	01	A	A	A	L060

1.	VALVE SERIES, CONNECTION AND FACE TO FACE LENGTH
ZX	RotaryGlobe valve, flanged, f-to-f length acc. to ISA S75.03 and EN 558-2 series 37-39

2.	PRESSURE RATING, FLANGES, FLANGE DRILLINGS
C	ASME class 150
D	ASME class 300
F	ASME class 600
G	ASME class 900
H	ASME class 1500
M	PN40 (PN10-40) (body face to face acc. ASME 300)
N	PN63 (body face to face acc. ASME 600)
P	PN100 (body face to face acc. ASME 600)

3.	SIZE
0H	½"
3Q	¾"
01	1"
1H	1½"
02	2"
03*	3"
04*	4"

*) 3" and 4" only available in ASME pressure classes 900 and 1500

4.	BODY MATERIAL & BODY RELATED MATERIALS
	Standard materials
	Body and bonnet
A	CF8M / 1.4408
D	WCC / 1.0619
	Optional materials
	Body and bonnet
J	WC6 / F11 Cl 2

5.	PLUG, STEM, PIN AND SEAT CAGE MATERIALS			
	Standard materials			
	Plug	Stem and pin	Seat Cage	Max. temp.
A	17-4PH + HCr	AISI 316	Nitronic 60	425 °C
	Optional materials			
	Plug	Stem and pin	Seat Cage	Max. temp.
J	17-4PH + HCr	AISI 316	Nitronic 50	425 °C

6.	PACKING	SEALS
	Standard	
A	PTFE	Graphite
T	Live loaded PTFE	Graphite
F	Graphite	Graphite
G	Live loaded graphite	Graphite
	Optional	
P	PTFE	PTFE
S	Live loaded PTFE	PTFE

7.	TRIM		
C _V VALUES FOR SIZES DN15 - DN25 / 1/2"-1"			
TRIM TYPE	DESCRIPTION (SIZE)	C _V VALUE	INITIAL OPENINGS (h ₀) in %

L001	Linear (DN15-DN25 / 1/2" - 1")	0.1	16.7
L003	Linear (DN15-DN25 / 1/2" - 1")	0.3	16.7
L011	Linear (DN15-DN25 / 1/2" - 1")	1.1	16.7
L025	Linear (DN15-DN25 / 1/2" - 1")	2.5	16.7
L060	Linear (DN20-DN25 / 3/4" - 1")	6.0	15.0
L120	Linear (DN25 / 1")	12.0	12.8
E011	Equal % (DN15-DN25 / 1/2" - 1")	1.1	8.9
E022	Equal % (DN15-DN25 / 1/2" - 1")	2.2	15.6
E043	Equal % (DN15-DN25 / 1/2" - 1")	4.3	15.0
E090	Equal % (DN 25 / 1")	9.0	12.8
B020	Balanced trim for high Δp and noise reduction. Linear (DN15-DN25 / 1/2" - 1")	2.0	15.0
B050	Balanced trim for high Δp and noise reduction. Linear (DN20-DN25 / 3/4" - 1")	5.0	15.0

C_V VALUES FOR SIZES DN40 - DN50 / 1 1/2"- 2"

TRIM TYPE	DESCRIPTION	C _V VALUE	INITIAL OPENINGS (h ₀) in %
L030	Linear	3.0	15.0
L070	Linear	7.0	15.0
L150	Linear	15.0	13.3
L310	Linear	31.0	12.8
E115	Equal %	11.5	13.3
E260	Equal %	26.0	12.8
B050	Balanced trim for high Δp and noise reduction. Linear.	6.0	15.0
B130	Balanced trim for high Δp and noise reduction. Linear.	13.0	15.0

C_V VALUES FOR SIZE DN 80 / 3"

TRIM TYPE	DESCRIPTION	C _V VALUE	INITIAL OPENINGS (h ₀) in %
L180	Linear	18	8.9
L350	Linear	35	9.4
L550	Linear	55	8.3
E320	Equal %	32	10.0
E460	Equal %	46	8.9
B130	Balanced trim for high Δp and noise reduction. Linear.	13	9.4
B280	Balanced trim for high Δp and noise reduction. Linear.	28	9.4

C_V VALUES FOR SIZE DN 100 / 4"

TRIM TYPE	DESCRIPTION	C _V VALUE	INITIAL OPENINGS (h ₀) in %
L350	Linear	35	9.4
L700	Linear	70	9.4
L1150	Linear	115	9.4
E540	Equal %	54	9.4
E800	Equal %	80	9.4
B280	Balanced trim for high Δp and noise reduction. Linear.	28	10.0
B520	Balanced trim for high Δp and noise reduction. Linear.	52	10.0

Subject to change without prior notice.

14. GENERAL SAFETY WARNINGS AND DISCLAIMERS

General safety warnings

Lifting

1. Always use a lifting plan created by a qualified person to lift this equipment. Lifting guidance is provided in this IMO (Installation, Maintenance and Operation manual) to assist in lifting plan development. Think about the center of gravity (CG) of the equipment being lifted. Make sure the CG is always under the central lifting point.
2. Valves may be equipped with lifting threads on the body or on the flanges. These are intended to be used with the lifting plan.
3. Use only correct and approved lifting devices. Ensure that lifting devices and straps are securely attached to the equipment prior to lifting.
4. Check, that lifting devices are not damaged and in good condition with a valid check stamp prior to use.
5. Workers must be trained for lifting and handling valves.
6. Never lift an assembly by the instrumentation (solenoid, positioner, limit switch, etc.) or by the instrumentation piping. Straps and lifting devices should be fitted to prevent damage to instrumentation and instrumentation piping. Failure to follow the lifting guidance provided may result in damage and personal injury from falling objects.

Work activities on the valve

1. Wear your personal safety equipment. Personal safety equipment includes but is not limited to protective shoes, protective clothing, safety glasses, helmet, hearing protection and working gloves.
2. Always follow the local safety instructions in addition to the Valmet instructions. If Valmet instructions conflict with local safety instructions, stop work and contact Valmet for more information.
3. Before beginning service on the equipment, make sure that the actuator is disconnected from any kind of power source (pneumatic, hydraulic, and/or electric), and no stored energy is applied on the actuator (compressed spring, compressed air volumes, etc.). Do not attempt to remove a spring return actuator unless the stop screw is carrying the spring force.
4. Make sure that there is a LOTOTO (Lock Out / Tag Out / Try Out) procedure in place for the system in which the valve is installed and strictly follow it.
5. Always make sure that the pipeline is depressurized and in ambient temperature condition before maintenance work is started.
6. Keep hands and other body parts out of the flow port when the valve is being serviced and the actuator is connected to the valve. There is a high risk of serious injury to hands and/or fingers due to malfunction if the valve suddenly starts to operate.
7. Beware of Trim (Disc, Ball or Plug) movement even when the valve is disassembled. Trim may move simply due to the weight of the part or change in position of the valve. Keep hands or other body parts away from locations where they may be injured by movement of the trim. Do not leave objects near or in the valve port which may fall in and need to be retrieved.

General disclaimers

Receive, handle and unpacking.

1. Respect the safety warnings above!
2. Valves are critical components for pipelines to control high pressure fluids and must therefore be handled with care.

3. Store valves and equipment in a dry and protected area until the equipment is installed.
4. Do not exceed the maximum storage temperatures given in the IMO (installation, maintenance, and operating instructions).
5. Keep the original packaging on the valve as long as possible to avoid environmental contamination by dust, water, dirt, etc.
6. Remove the valve endcaps just before mounting into the pipeline.
7. FOR YOUR SAFETY IT IS IMPORTANT TO FOLLOW THESE PRECAUTIONS BEFORE REMOVAL OF THE VALVE FROM THE PIPELINE OR ANY DISASSEMBLY:
 - Be sure you know what flow medium is in the pipeline. If there is any doubt, confirm with the proper supervisor.
 - Wear any personal protective equipment (PPE) required for working with the flow medium involved in addition to any other PPE normally required.
 - Depressurize the pipeline, bring to ambient temperature, and drain the pipeline flow medium.
 - Cycle the valve to relieve any residual pressure in the body cavity.
 - After removal but before disassembly, cycle the valve again until no evidence of trapped pressure remains.
 - The valves with offset shaft (Butterfly, eccentric rotary plug) have greater trim area on one side of the shaft. This will cause the valve to open when pressurized from the preferred direction without a locking handle or an actuator installed.
 - **WARNING: DO NOT PRESSURIZE THE ECCENTRIC VALVE WITHOUT A HANDLE OR AN ACTUATOR MOUNTED ON IT!**
 - **WARNING: DO NOT REMOVE A HANDLE OR AN ACTUATOR FROM AN ECCENTRIC VALVE WHILE PRESSURIZED!**
 - Before installing the eccentric valve in or remove it from the pipeline, cycle the valve closed. Eccentric valves must be in the closed position to bring the trim within the face to face of the valve. Failure to follow these instructions will cause damage to the valve and may result in personal injury.

Operating

8. The identification plate (ID-plate, type plate, nameplate, or engraved markings) on the valve gives the information of max. process conditions to the valve.
9. (For soft seats) The practical and safe use of this product is determined by both the temperature and pressure ratings of the seat and body. Read the identification plate and check both ratings. This product is available with a variety of seat materials. Some seat materials have pressure ratings that are lower than the body ratings. All body and seat ratings are dependent on the valve type, size and material of the body and seat. Never exceed the marked rating.
10. Temperatures and pressures must never exceed values marked on the valve. Exceeding these values may cause uncontrolled release of pressure and process medium. Damage or personal injury may result.
11. The operating torque of the valve may rise over time due to wear, particles or other damage of the seat. Never exceed the actuator torque preset values (air supply, position). Application of excessive torque may cause damage to the valve.
12. Valmet valves typically are designed to be used in atmospheric conditions. Do not use valves under external pressurized conditions unless specifically designed and explicitly marked for this service.

13. Avoid Pressure shocks or water hammer. Systems with high pressure valves should be equipped with a bypass to reduce the differential pressure before opening the valve to avoid pressure shock.
14. Avoid thermal shock. High temperature, Low temperature and cryogenic valves should be operated in a way that limits the rate of increase or decrease in temperature. The valve should be thermally stabilized before being pressurized.
15. Materials of the valve are carefully selected for the process conditions. Changes to the process media can have a major impact on function and safety of the valve. Always confirm the materials are suitable for the service prior to installation.
16. As the use of the valve is application specific, several factors should be considered when selecting a valve for a given application. Therefore, some situations in which the valves are used are outside the scope of this manual.
17. It is the end user's responsibility to confirm compatibility of the valve materials with the intended service, however if you have questions concerning the use, application, or compatibility of the valve for the intended service, contact Valmet for more information.
18. Never use a valve with enriched or pure oxygen if the valve is not explicitly designed and cleaned for oxygen. Selected materials and design have a major impact on the safety to operate the valve with oxygen.
19. Valves intended for use in or with explosive atmospheres must be equipped with a grounding device and marked according ATEX (or equivalent international standards).
20. Manual handles are available for specific butterfly valve sizes and maximum line pressures. Do not operate a valve with a handle or wrench outside the size and pressure limits stated in the IMO. High line pressure may create a large enough force to pull the handle from the operator's hands. Damage or personal injury may result.

Maintenance

21. Respect the safety warnings above!
22. Plan service and maintenance actions, that spare parts, lifting devices and service personnel is available.
23. Maintain the valve within the recommended minimum maintenance intervals or within the recommended maximum operating cycles.
24. Always make sure that the valve and the pipeline is depressurized before starting any kind of maintenance work at a valve.
25. Always check the position of the valve before starting maintenance work. Follow the Lock out /tag out (LOTO) rules at the site before starting any maintenance activity.
 - See IMO for the correct stem position.
 - Consider that the positioner may give the wrong signals.
26. Sealing materials (soft sealing parts) should be changed when the valve is maintained. Always use original equipment manufacturers (OEM) spare parts to ensure proper performance of the repaired valve.
27. All pressure containing parts must be inspected visually for damage or corrosion. Damaged parts must be replaced.
28. Valve pressure retaining parts and all internals must be inspected for corrosion or erosion which may result in reduced wall thickness on pressure retaining parts. Damaged pressure retaining parts must be replaced with original equipment manufacturer's (OEM) replacement parts or repaired to factory specifications by an authorized Valmet service partner in order to maintain the warranty.
29. Do not use sharp tools, grinding machines, or files to work on functional surfaces such as sealing, seating or bearing surfaces as this can damage these surfaces.
30. Check the condition of sealing surfaces on the seats, trim (disc, ball, plug, etc.), body and body cap. Replace parts if there are significant wear, scratches, or damage.
31. Check the wear of bearings and bearing contact surfaces on the shaft and replace damaged parts if necessary.
32. Do not weld on pressure retaining parts without an ASME and PED qualified procedure and personnel.
33. Pressure retaining parts of valves in high temperature applications must be carefully examined for the effects of material creep and fatigue.
34. Make sure that the valve is positioned in the correct flow direction into the pipeline.
35. If the valves are marked to be suitable for explosive atmospheres, the correct function of the discharging device must be tested before returning to service.
36. Always work in a clean environment. Avoid getting particles inside the valve due to machining, grinding, or welding nearby.
37. Never store a maintained valve without flow port protection.
38. When pressure testing valve seats, never exceed the maximum operating pressure of the system or the maximum shut-off pressure marked on the valve identification plate.
39. Actuator mounting and unmounting:
 - Before installing the actuator on to the valve, be sure the actuator is properly indicating the valve position. Failure to assemble these to indicate correct valve position may result in damage or personal injury.
 - When installing or removing a linkage kit, best practice is to remove the entire linkage assembly, including couplings which may fall off the valve during lifting or when position changes.
 - Mounting sets have been designed to support the weight of the Valmet actuator and recommended accessories either as is or with additional actuator support. Use of the linkage to support additional equipment or additional weight such as people, ladders, etc. may result in equipment damage or personal injury.
40. The valve should be installed between flanges using appropriate gaskets and fasteners that are compatible with the application, and in compliance with applicable piping codes and standards. Center the gaskets carefully when fitting the valve between the flanges. Do not attempt to correct pipeline misalignment by means of the flange bolting.
41. Repairs on valves for special service like Oxygen, Chlorine, and Peroxide, have special requirements.
 - Parts must be cleaned appropriate to the service and protected from contamination prior to assembly.
 - Assembly areas and tools must be clean and dry to prevent contamination of the parts during assembly.
 - Test equipment must be clean and dry to prevent contamination during testing. This includes the test equipment internals that may allow particles or other contamination into the test medium during the test.
 - Lubrication shall be used only if specifically required in the instructions. Where lubrication is required, the lubricant must be approved for the service by the end user.

Valmet Flow Control Oy

Vanha Porvoontie 229, 01380 Vantaa, Finland.

Tel. +358 10 417 5000.

www.valmet.com/flowcontrol

Subject to change without prior notice.

Neles, Neles Easyflow, Jamesbury, Stonel, Valvcon and Flowrox, and certain other trademarks, are either registered trademarks or trademarks of Valmet Oyj or its subsidiaries in the United States and/or in other countries.

