

Neles™ 6D series trunnion ball valves

Installation, maintenance and
operating instructions



Table of contents

GENERAL	3	TROUBLE SHOOTING	16
Scope	3	TOOLS	16
Valve description	3	ORDERING SPARE PARTS	16
Markings	3	EXPLODED VIEW AND PARTS LIST	17
Specifications	4	NPS 2 & 3 ASME Class 150 & 300	17
Valve approvals	4	NPS 4 to 24 ASME Class 150 & 300	18
CE and ATEX marking	4	NPS 2 to 24 ASME Class 600	19
Recycling and disposal	4	NPS 2 to 12 ASME Class 900 & 1500	20
Safety precautions	4	DIMENSIONS & WEIGHT	21
TRANSPORTATION, RECEPTION AND STORAGE	7	Bare valve	21
INSTALLATION AND USE	7	Valve with manual operator	26
General	7	EU DECLARATION OF CONFORMITY FOR ATEX APPROVED VALVES	30
Installing the valve in pipeline	7	HOW TO ORDER	31
Actuator	8	GENERAL SAFETY WARNINGS AND DISCLAIMERS	32
Commissioning	8	General safety warnings	32
MAINTENANCE	8	General disclaimers	32
Maintenance general	8		
Changing the gland packing while the valve is in pipeline	8		
Repair of a jammed or stuck valve while it is in the pipeline	11		
Detaching the actuator	11		
Removing valve from pipeline	11		
Dismantling the valve	11		
Inspection of removed parts	12		
Replacing parts	12		
Re-assembly of the valve	12		
TESTING THE VALVE	13		
INSTALLING THE ACTUATOR	14		
General	14		
Installing manual operators (MGR series)	14		
Installing pneumatic actuators (B1 series)	14		
Installing other makes of actuators	15		

Subject to change without notice.

All trademarks are property of their respective owners.

READ THESE INSTRUCTIONS FIRST!

These instructions provide information about safe handling and operation of the valve.

If you require additional assistance, please contact the manufacturer or manufacturer's representative.

SAVE THESE INSTRUCTIONS!

Addresses and phone numbers are printed on the back cover.

1. GENERAL

1.1 Scope

This installation, operation and maintenance manual provides essential information on trunnion mounted Neles 6D series ball valves. The actuators and instrumentation to be used with these valves are also discussed briefly. Refer to the separate actuator and control equipment instruction manuals for further information.

NOTE:

Selection and use of the valve in a specific application requires close consideration of detailed aspects. Note also the possibility of clogging / jamming when inappropriately selected. Due to the nature of the product, this manual cannot cover all the individual situations that may occur when installing, using or servicing the valve.

If you are uncertain about use of the valve or its suitability for your intended purpose, please contact Valmet for more information.

This product is not suitable for oxygen, hydrogen peroxide, chlorine, bromine, and cryogenic services.

1.2 Valve description

Trunnion mounted 6D series valves are flanged full bore ball valves. The valve body is in two or three parts, fastened together by body-body cap bolting. The ball and stem are separate. Stem blow-out is prevented by stem housing / bonnet and a shoulder machined on the stem. The valve is soft seated. Stem torque is transmitted to the ball through a drive in the ball.

The valve is 1-way or 2-way tight depending on the seat construction. Tightness direction is shown with an arrow on 1-way valves.

Construction details of individual valves are included in the type code (ordering code) shown on the valve name plate. To interpret the type code, please refer to the type coding key in this manual. Neles 6D series ball valves are specially designed for isolation service with low or high pressure differentials.

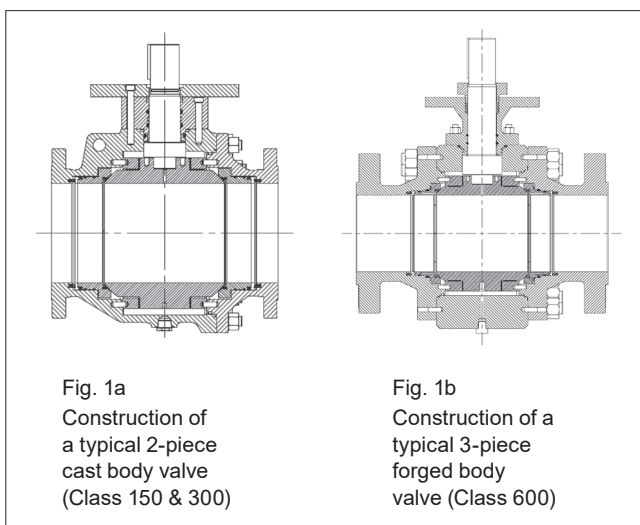

Fig. 1

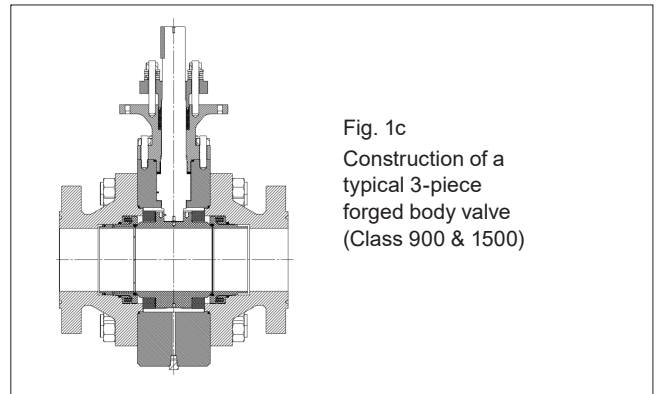

Fig. 1c
Construction of a typical 3-piece forged body valve (Class 900 & 1500)

Fig. 1

1.3 Markings

Body markings are cast or stamped on the body depending up on body material (see Figure 1).

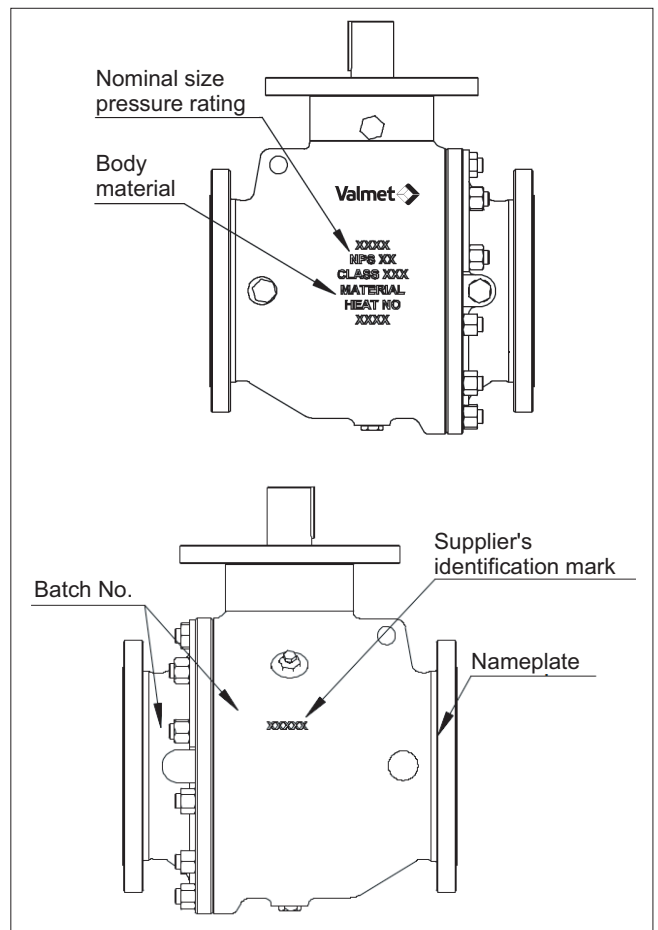

Fig. 2 Valve markings

The name plate (Figure 3) is attached to the body flange. Name plate markings are:

1. Body material
2. Stem material
3. Trim material
4. Seat material
5. Maximum and minimum operating temperature
6. Maximum shut-off pressure differential / temperature
7. Pressure class
8. Type designation
9. Valve manufacturing order no
10. Model

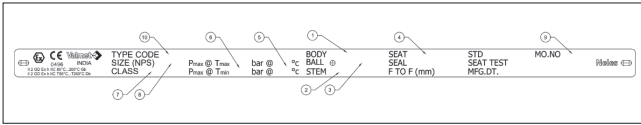

Fig. 3 Example of valve name plate

1.4 Specifications

Face-to-face length:	API 6D & ASME B.16.10 long pattern
Body rating:	ASME Class 150, 300, 600, 900, 1500
Max. pressure differential:	see Fig. 4
Temperature range:	-46°...+230 °C -51°...+446 °F
Tightness:	Bi-directional Soft seated API 6D, API 598, ASME B16.34, EN 12266, ISO 5208 Rate-A
Dimensions:	see section 11
Weights:	see section 11

Maximum allowable ΔP in isolation service

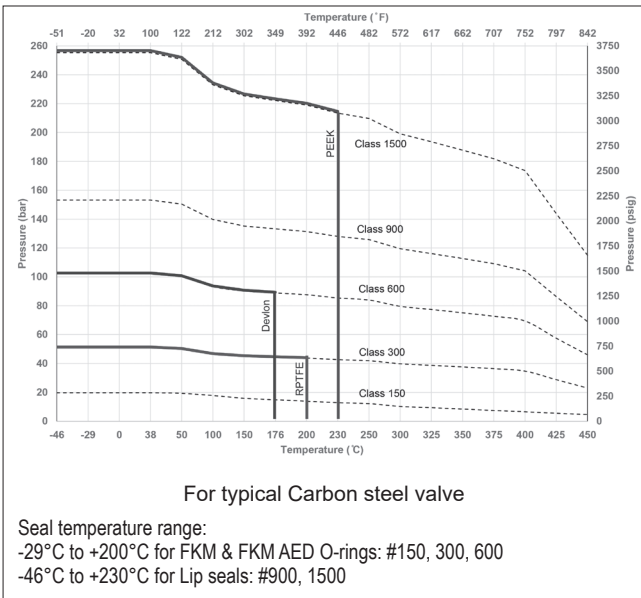

Fig. 4 Maximum allowable Δp for isolation service (typical Carbon steel valve)

1.5 Valve approvals

Neles 6D series ball valves meet the requirements of API 6D, IOGP S-562, ASME B16.34, and ISO 17292. Fire safe according to API 607 & ISO 10497.

1.6 CE and ATEX marking

The valve meets the requirements of the European Directive 2014/68/EU relating to pressure equipment, and has been marked according to the Directive. Valves with API 6D monogram are not offered with CE-PED approval.

When applicable, the valve meets the requirements of the European Directive 2014/34/EU relating to equipment and protective systems intended for use in potentially explosive atmosphere, and has been marked according to the Directive

1.7 Recycling and disposal

Most valve parts can be recycled if sorted according to material. Most parts have material marking. A material list is supplied with the valve. In addition, separate recycling and disposal instructions are available from the manufacturer on request. A valve can also be returned to the manufacturer for recycling and disposal against a fee.

Refer to Valmet publication 10RC70en for more information.

1.8 Safety precautions

CAUTION:

Do not exceed the valve performance limitations! Exceeding the limitations marked on the valve may cause damage and lead to uncontrolled pressure release. Damage or personal injury may result.

CAUTION:

When handling the valve or the valve package, bear in mind its weight!. Never lift the valve or valve package by the actuator, controller, limit switch or their tubing. Place the lifting ropes securely around the valve body (see Figure 5). Damage or personal injury may result from falling parts. The weights are shown in section 11.

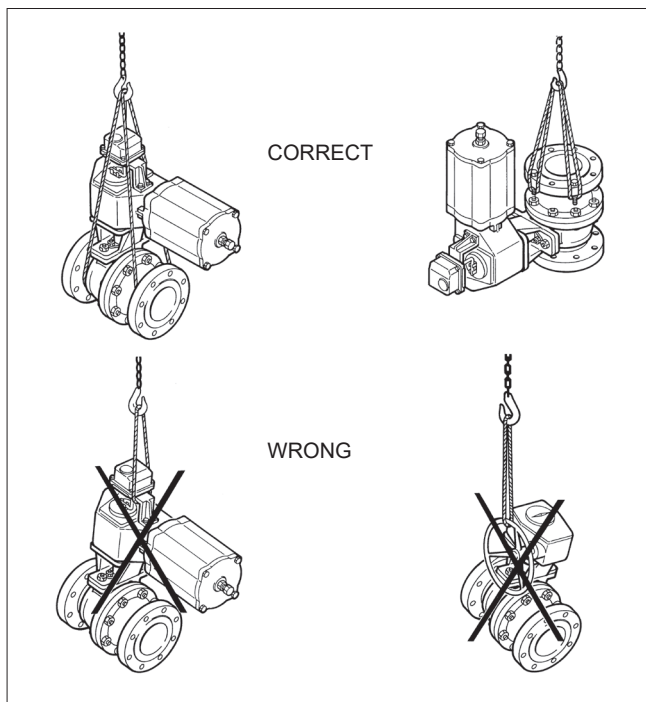

Fig. 5 Lifting the valve

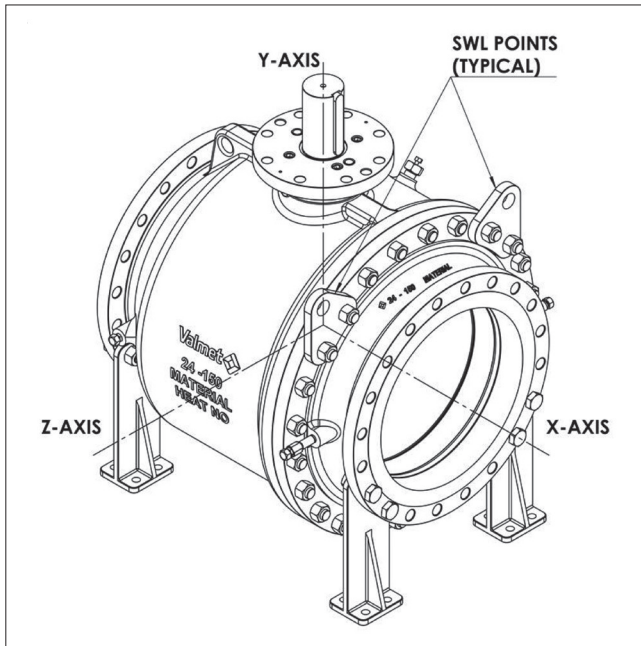

Fig. 6

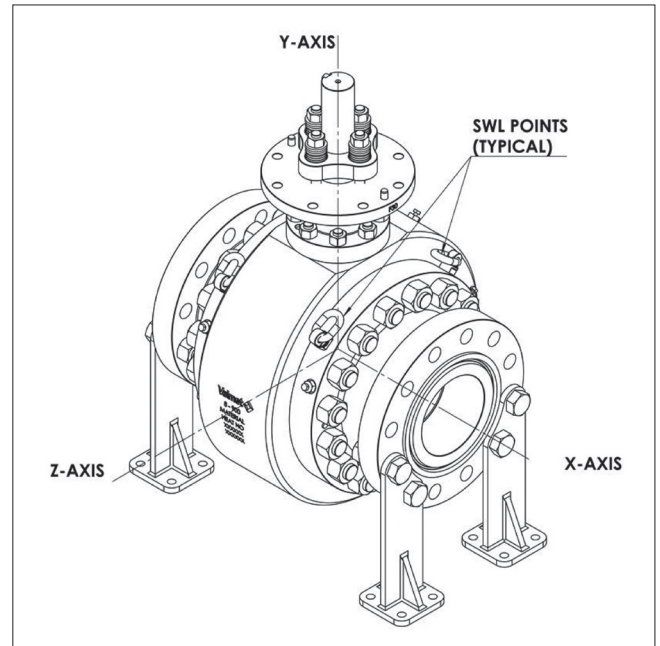

Fig. 7

Size (NPS)	Class	Valve Centre of gravity (CG) plot in mm		
		X ±5	Y ±5	Z ±5
2	150	5	55	1
	300	4	54	1
3	150	6	54	1
	300	1	54	0
4	150	4	43	0
	300	13	24	0
6	150	8	65	0
	300	8	61	0
8	150	6	64	0
	300	9	59	0
10	150	8	51	0
	300	11	58	0
12	150	7	70	0
	300	13	39	0
14	150	18	45	-1
	300	16	52	0
16	150	15	62	0
	300	9	81	0
18	150	21	63	0
	300	22	75	0
20	150	24	40	0
	300	28	55	0
24	150	18	58	0
	300	27	55	0

Size (NPS)	Class	Valve Centre of Gravity (CG) plot in mm		
		X ±2	Y ±2	Z ±2
2	600	0	10	1
3	600	0	14	0
4	600	0	12	0
6	600	0	9	0
8	600	0	16	0
10	600	0	14	0
12	600	0	13	0
14	600	0	13	0
16	600	0	7	0
18	600	0	13	0
20	600	0	13	0
24	600	0	17	0

Size (NPS)	Class	Valve Centre of Gravity (CG) plot in mm		
		X ±2	Y ±2	Z ±2
2	900	0	11	0
3	900	0	18	0
4	900	0	12	0
6	900	0	13	0
8	900	0	18	0
10	900	0	-2	0
12	900	0	10	0

Size (NPS)	Class	Valve Centre of Gravity (CG) plot in mm		
		X ±2	Y ±2	Z ±2
2	1500	0	11	0
3	1500	0	11	0
4	1500	0	11	0
6	1500	0	8	0
8	1500	0	14	0
10	1500	0	-2	0
12	1500	0	9	0

Size (NPS)	Class	Safe working load (SWL) in kg
4	150	700
	300	800
6	150	800
	300	900
8	150	1300
	300	1300
10	150	1350
	300	1650
12	150	1950
	300	1700
14	150	1950
	300	2200
16	150	2650
	300	3350
18	150	3350
	300	4450
20	150	4000
	300	4450
24	150	8350
	300	8350

Size (NPS)	Class	Safe working load (SWL) in kg
2	600	250
3	600	350
4	600	450
6	600	900
8	600	750
10	600	1700
12	600	2450
14	600	2950
16	600	3200
18	600	3650
20	600	4500
24	600	8500

Size (NPS)	Class	Safe working load (SWL) in kg
2	900	1200
3	900	1200
4	900	1200
6	900	5600
8	900	5600
10	900	5600
12	900	5600

Size (NPS)	Class	Safe working load (SWL) in kg
2	1500	1200
3	1500	1200
4	1500	1200
6	1500	5600
8	1500	5600
10	1500	5600
12	1500	5600

CAUTION:

Follow the proper procedures when handling and servicing valves with special cleaning or processing.

CAUTION:

Do not dismantle the valve or remove it from the pipeline while the valve is pressurized!. Dismantling or removing a pressurized valve will result in uncontrolled pressure release. Always isolate the relevant part of the pipeline, release the pressure from the valve and remove the medium before dismantling the valve. Be aware of the type of medium involved. Protect people and the environment from any harmful or poisonous substances. Make sure that no medium can enter the pipeline during valve maintenance. Failure to do this may result in damage or personal injury.

CAUTION:

Valve has a one-piece solid mirror finished ball with internal relief hole to avoid cavity over pressurization in valve open condition. This do not make the valve unidirectional.

CAUTION:

Beware of the ball cutting movement!. Keep hands, other parts of the body, tools and other objects out of the open flow port. Leave no foreign objects inside the pipeline. When the valve is actuated, the ball functions as a cutting device. Close and detach the actuator pressure supply pipeline for valve maintenance. Failure to do this may result in damage or personal injury.

CAUTION:

Beware of noise emission!. The valve may produce noise in the pipeline. The noise level depends on the application. It can be measured or calculated using the Valmet's Nelprof sizing program. Observe the relevant work environment regulations on noise emission.

CAUTION:

Beware of extreme temperatures!. The valve body may be very hot or very cold during use. Protect people against cold injuries or burns.

ATEX/Ex safety

CAUTION:

Potential electrostatic hazard, ensure the protection (grounding, etc.) in the process.

CAUTION:

The actual surface temperature of valve is dependent on the process temperature. The protection from high or low temperature must be considered by the end user before valve is put into service.

CAUTION:

Ensure the general process and worker protection from static electricity in the facilities.

2. TRANSPORTATION, RECEPTION AND STORAGE

Check the valve and the accompanying device for any damage that may have occurred during transport. Store the valve carefully. We recommend storing indoors in a dry place.

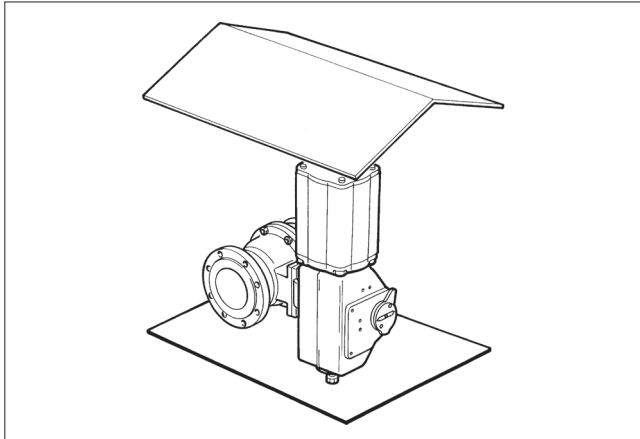

Fig. 8 Storing the valve

Do not remove flow port protectors until installing the valve. Move valve to its intended location just before installation. The valve is usually delivered in the open position.

3. INSTALLATION AND USE

3.1 General

Remove the flow bore protectors and check that the valve is clean inside. Clean the valve if necessary.

3.2 Installing the valve in pipeline

CAUTION:

When handling the valve or the valve package as a whole, bear in mind the weight of the valve or the entire package!

Flush the pipeline carefully before installing the valve. Make sure the valve is entirely open when flushing. Foreign particles, such as sand or pieces of welding electrode, will damage the ball and seats. Refer to Valmet publication 10LIFT70en for lifting instructions.

NOTE:

Center the flange gaskets carefully when fitting the valve between flanges.

NOTE:

Do not attempt to correct pipeline misalignment by means of flange bolting.

The valve may be installed in any position and offers 1-way or 2-way tightness, see Sections 1.2 and 1.4. However we do not recommend installing the valve with the actuator on the underneath side because dirt in the pipeline may enter the body cavity and damage the gland packing. The position to be avoided is shown in Figure 9.

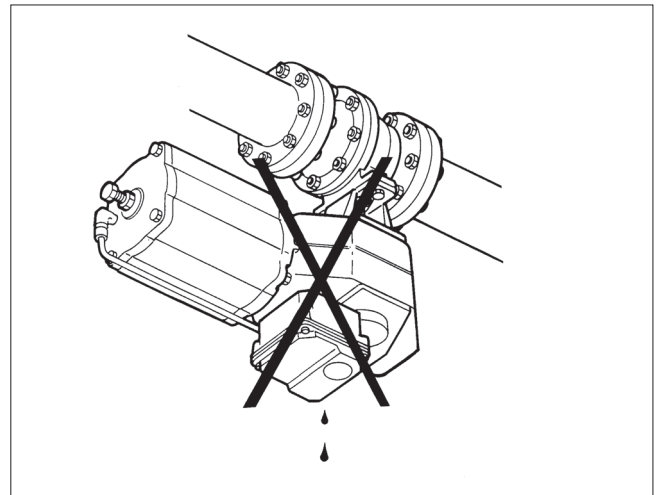

Fig. 9 Avoid this mounting position

It may be necessary to firmly support the pipeline in order to protect the valve from excess stress. Sufficient support will also reduce pipeline vibration and thus ensures proper functioning of the controller mounted on top of valve.

To facilitate servicing, it is preferable that the valve be supported by the body, using pipe clamps and supports. Do not fasten supports to the flange bolting or to the actuator, see Figure 10.

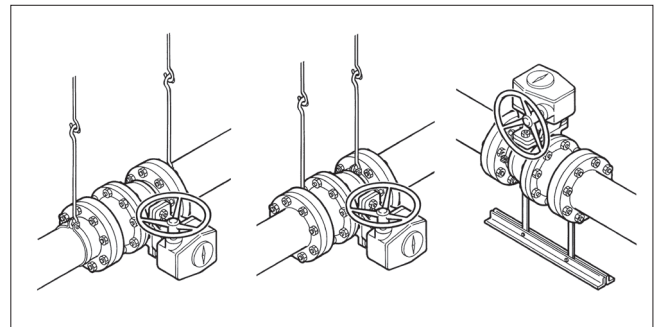

Fig. 10 Supporting the valve

Valve insulation

If necessary, the valve may be insulated. Insulation must not continue above the upper level of the valve body, see Figure 11.

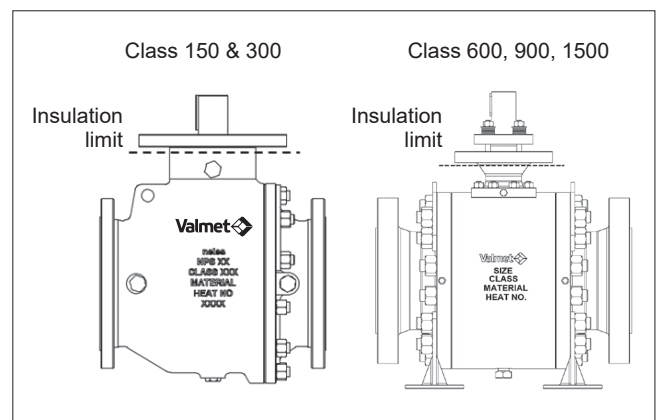

Fig. 11 Insulation of the valve

3.3 Actuator

NOTE:

When installing the actuator on the valve, make sure that the valve package functions properly. Detailed information on actuator installation is given in Section 6 or in the separate actuator instructions.

The valve open/closed position is indicated as follows:

- by an indicator on the actuator or
- by the keyway on valve stem

If there is any uncertainty about the indicator, check the ball position by the stem keyway. When stem keyway is on body or body cap side, the valve is in open position (see Figure 12).

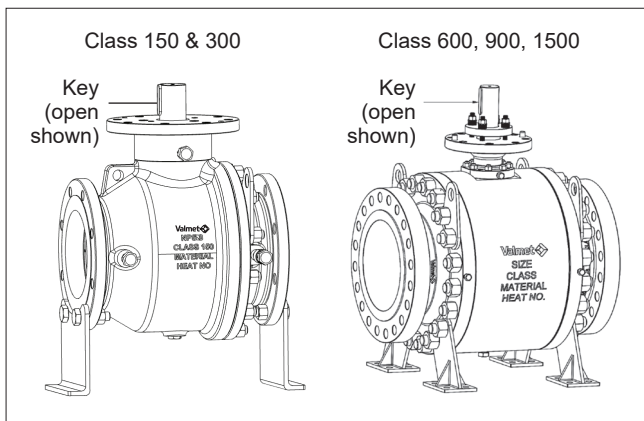

Fig. 12 Valve open / close indication by stem keyway

The actuator should be installed in a manner that allows plenty of room for its removal. The upright position is recommended for the actuator cylinder. The actuator must not touch the pipeline, because pipeline vibration may interfere with its operation.

In certain cases, it may be considered advantageous to provide additional support to the actuator. These cases will normally be associated with large actuators, extended shafts, or where severe vibration is present. Please contact nearest Valmet location for advice.

3.4 Commissioning

Ensure that there is no dirt or foreign objects left inside the valve or pipeline. Flush the pipeline carefully. Make sure that the valve is entirely open when flushing. Ensure that all nuts, pipings, and cables are properly fastened. Check that the actuator, positioner, and switch are correctly adjusted. Actuator adjustment is explained in Section 6. To adjust the accompanying device, refer the separate control equipment instruction manuals.

4. MAINTENANCE

CAUTION:

Observe the safety precautions mentioned in Section 1.8 before maintenance!

CAUTION:

When handling the valve or the valve package as a whole, bear in mind the weight of the valve or the entire package!

4.1 Maintenance general

Although valves are designed to work under severe conditions, proper preventative maintenance can significantly help to prevent unplanned downtime and in real terms reduce the Total Cost of Ownership (TCO). Valmet recommends inspecting the valves at least every *five* years. Refer specific service recommendation documents, if applicable. The inspection and maintenance interval depends on the actual application and process condition. The inspection and maintenance intervals can be specified together with your local Valmet experts. During this periodic inspection, the parts detailed in the spare part set should be replaced. Time in storage should be included in the inspection interval.

Maintenance can be performed as presented below. For maintenance assistance, please contact your local Valmet office. The part numbers in the text refer to the exploded view and to the parts list in Section 10, unless otherwise stated.

NOTE:

When sending goods to the manufacturer for repair, do not disassemble them. Clean the valve carefully and flush the valve internals. For safety reasons, inform the manufacturer of the type of medium used in the valve (include material safety datasheets (MSDS)).

NOTE:

In order to ensure safe and effective operation, always use original spare parts to make sure that the valve functions as intended.

NOTE:

For safety reasons, replace pressure retaining bolting if the threads are damaged, have been heated, stretched or corroded.

4.2 Changing the gland packing while the valve is in pipeline

CAUTION:

Do not dismantle the valve or remove it from the pipeline while the valve or pipeline is pressurized!

NOTE:

If the valve is not installed in pipeline containing lethal or hazardous fluids, then open the bleeder valve (40) to completely relieve cavity pressure, if any, before attempting to replace gland packing.

The valve has multi-layer stem sealing arrangement. The primary seal being the stem thrust washer (23), secondary seal being O-rings (22), and tertiary seal being graphite gland packing rings (31). Leakage through stem seal may occur only after failure of all sealing elements. To arrest the gland leakage in Class 150 & 300 rated valves, cap screws (33) must be tightened until the mounting flange (32) rests completely on stem housing (26). The gland packing (31) must be changed if leakage occurs even after the cap screws (33) are tightened (refer Table-2). To arrest the gland leakage in Class 600, 900, 1500 rated valves, hex nut (56) must be tightened as per Table 3 & 4. The gland packing (31) must be changed if leakage occurs even after tightening.

NOTE:

If the pressure inside the valve can't be drained, then pump emergency stem sealant through the sealant injection grease fitting (39) and avoid operating the valve until the next available maintenance schedule.

NOTE:

Class 150 & 300 rated valves have 2 ring packing configuration. All other higher pressure class rated valves have multi-ring configuration that are supplied as a set in ready to use condition. Do not separate the multi-ring set. No stem seal O-rings are used in Class 900 & 1500 rated valves.

Table 1 Fastener tightening torque (max.) for inch series (with anti-seize compound applied)

Material	ASTM A193 B7	ASTM A193 B8M class-1
Bolt size (inch)	Tightening torque (Nm)	Tightening torque (Nm)
3/8"-16TPI	38	15
1/2"-13TPI	87	34
5/8"-11TPI	173	65
3/4"-10TPI	301	113
1"-8TPI	719	267
1.1/8"-8TPI	1043	380
1.1/4"-8TPI	1451	541
1.3/8"-8TPI	1953	728
1.5/8"-8TPI	3276	1221
1.3/4"-8TPI	4126	1539
1.7/8"-8TPI	5102	1903
2"-8TPI	6230	2323
2.1/4"-8TPI	8956	3338
2.1/2"-8TPI	12348	4603

CAUTION:

Pumping emergency sealant is a temporary measure and gland packing must be replaced as soon as possible. Valve must never be operated after emergency sealant is used. Else, there will be leakage again.

- Make sure that the valve is not pressurized
- Detach the actuator and mounting bracket according to the instructions in Section 4.4.
- Remove the key (25)
- For Class 150 & 300 rated valves, remove the cap screws (33) and mounting flange (32). For 600, 900, 1500 rated valves, remove the hex nut (56), flat washers (59), disc springs used for live loading (57), and gland (32/54). Pay attention to disc spring stack arrangement.
- Remove anti-extrusion ring (89) if available, and then also the old gland packing rings (31) using appropriate gland packing removal tools (see Figure 13). Do not damage the surfaces of the packing ring counterbore and stem.

Table 2 Fastener tightening torque (max.) for metric series (with anti-seize compound applied)

Material	ASTM A193 B7	ASTM A193 B8M Class-1
Bolt Size	Tightening Torque (Nm)	Tightening Torque (Nm)
M8	24	7
M10	47	13
M12	82	23
M14	130	37
M16	203	58
M18	279	79
M20	395	113
M22	538	153
M24	683	195
M27	999	285
M30	1357	386
M33	1847	526
M36	2372	675
M39	3069	874
M45	4739	1349

Table 3 Gland tightening torque (max.) for Class 600 (with anti-seize compound applied)

Gland tightening torque				
Size (NPS)	Gland stud size	Quantity per valve	Torque	
			ft-lbs	N-m
2	3/8"	4	8	11
3	1/2"	4	10	14
4	1/2"	4	24	32
6	1/2"	4	27	37
8	5/8"	4	49	66
10	5/8"	4	52	71
12	5/8"	4	64	87
14	3/4"	4	87	118
16	3/4"	4	87	118
18	3/4"	4	92	125
20	3/4"	4	100	136
24	3/4"	4	149	202

Table 4 Gland tightening torque (max.) for Class 900 & 1500 (with anti-seize compound applied)

Gland tightening torque				
Size (NPS)	Gland stud size	Quantity per valve	Torque	
			ft-lbs	N-m
2	1/2"	4	22	30
3	1/2"	4	37	50
4	1/2"	4	48	65
6	5/8"	4	77	105
8	7/8"	4	140	190
10	1"	4	207	280
12	1-1/8"	4	270	365



Fig. 13 Typical gland packing removal tool

- Clean the packing ring counterbore



- Place the new gland packing rings (31) over the stem (21). Install anti-extrusion ring (89) if available on top of the gland packing rings (31).
- When 2 ring sets are used with each ring having cut or slit, then insert the 2nd ring in a manner the cut or slit is 180° apart as compared with first ring. See Figure 14.

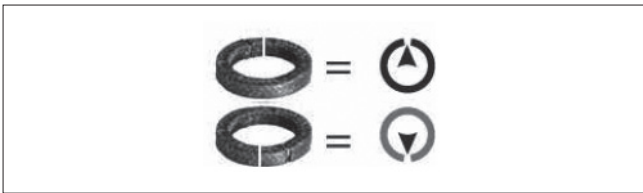

Fig. 14 Gland packing orientation

- Do not damage packing rings in the stem keyway
- The mounting flange or gland (32/54) must be used for pushing the rings into the counterbore
- See Figure 15 for details
- For Class 150 & 300 rated valves, install the cap screws (33) and and tighten them (refer Table-2). For 600, 900, 1500 rated valves, install gland (32/54), disc springs used for live loading (57), flat washers (59), hex nut (56), and tighten (refer Table-3). See below an indicative figure for arranging disc springs. Actual no. of springs can vary but shown below is a general arrangement.

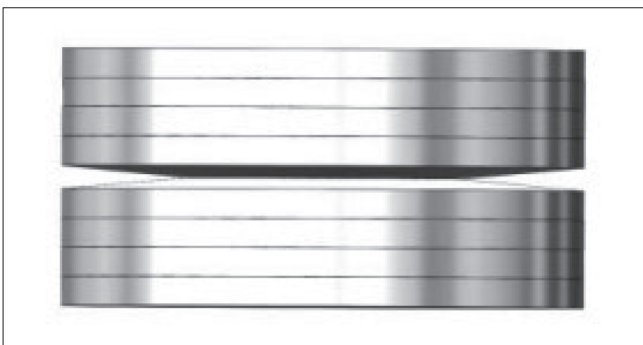

Fig. 15 Disc spring stack indicative view

- Operate the valve 6 cycles using suitable arrangement
- It is not necessary to fully close or open the valve during the operation

- For Class 150 & 300 rated valves, if the leakage still occurs when the valve is pressurized, re-tighten the cap screws the mounting flange (32) rests completely on stem housing (26)

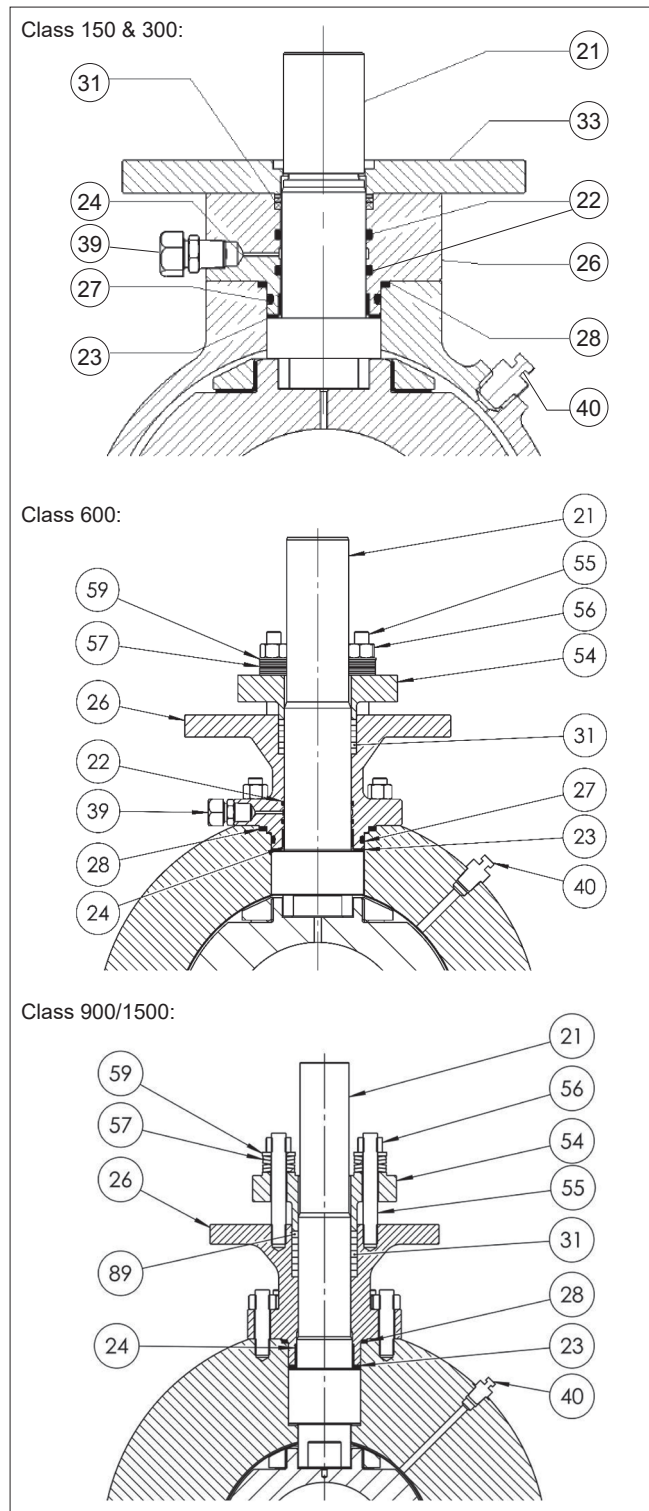

Fig. 16 View of multi-layer stem seal arrangement

4.3 Repair of a jammed or stuck valve while it is in the pipeline

Jamming may be due to the ball (9) and seats (10) becoming clogged with flow medium. They may be cleaned by turning the ball to the partly open position and flushing the pipeline. If this does not help, follow the instructions in the following sections.

4.4 Detaching the actuator

CAUTION:

When handling the valve or the valve package as a whole, bear in mind the weight of the valve or the entire package!

CAUTION:

Do not detach a spring-return actuator unless a stop-screw is carrying the spring force!

NOTE:

Before dismantling, carefully observe the position of the valve with respect to the actuator and positioner/limit switch to make sure that the package can be properly re-assembled.

It is generally most convenient to detach the actuator before removing the valve from the pipeline. If the valve is small or if it is difficult to access, it may be more practical to remove the entire package at the same time.

- Close and detach the actuator pressure supply pipeline and remove control cables
- Unscrew the bracket screw
- Detach the actuator. The actuator can be removed by hand or with a special tools (for B-series actuators) as applicable.
- The special tool can be ordered from the manufacturer (see Section 8)
- Remove the mounting bracket and allied fasteners

4.5 Removing valve from pipeline

CAUTION:

Do not dismantle the valve or remove pipeline while the valve is pressurized!

- Make sure that the valve is not pressurized and that the pipeline is empty. Make sure that the medium cannot flow into the section where servicing is to take place.
- Support the valve carefully with a hoist. Refer to Valmet publication 10LIFT70en for lifting instructions. Place ropes carefully and unscrew the pipe flange bolts. See that the ropes are positioned correctly, see Figure 5.

4.6 Dismantling the valve

- Place valve in the position such that body end flange is at the bottom. Use a level surface that will not scratch the body end flange. Ensure the body hex nuts (5) are facing upward. Clamp the valve firmly before proceeding further.
- Mark the the body halves for correct orientation during re-assembly
- Turn the ball to the closed position
- Remove the key (25)

- For Class 150 & 300 rated valves, unscrew the cap screws (33). Remove the mounting flange (32). For Class 600, 900, 1500 rated valves, unscrew the gland hex nuts (52/56). Remove the flat washers (59), disc spring stack used for live loading (57) and gland (32/54).
- Unscrew the body hex nuts (5)
- Remove the body cap (2). If the seat (10) is not lying on the ball (9), prevent the seat from falling from the body cap, and detach it later. Don't place your fingers between the body cap and the surface!
- Place the removed body cap on its end flange

NOTE:

Do not remove or damage the dowel pins (8) (20) (30) (82). Leave them "as it is", and they will be used again during reassembly.

CAUTION:

Check if the valve user has pumped emergency sealant during service. If so, then clean those metallic valve parts thoroughly to remove traces of emergency sealant prior to using them again.

- Remove the seat (10), seat retainer (14), socket head cap screws (84) if applicable, seat gasket (13), and springs (15 & 16) from body cap (2) if they are still inside. Discard the seat O-rings (11), lip seal (11), seat gasket (13), body O-rings (6), and body gasket (7). There shall be no scratches or dent marks on sealing zones during this process.
- Unscrew the stem housing cap screws (29) for Class 150 & 300 rated valves. Unscrew stem housing heavy hex nuts (52) for Class 600, 900, 1500 rated valve.
- Use the threaded holes provided in stem housing (26) and pull the entire part away from body (1). Exercise caution to avoid damage to stem sealing zones.
- Knock the stem housing (26) off with a piece of wood and a hammer, if needed

NOTE:

Spring energized lip seals are used as seat seals instead of O-rings in Class 900 & 1500 rated valves

- Carefully remove the gland packing rings (31) and anti-extrusion ring (89) if available as per section 4.2, stem housing O-ring (27), gasket (28), stem seal O-rings (22). Discard all these soft parts. There shall be no scratches or dent marks on sealing zones during this removal process.
- Remove and discard the stem thrust washer (23)
- Mark the valve stem keyway orientation / position of drive with ball
- Remove the valve stem (21)

Only for NPS 2 & 3 Class 150 & 300

- Remove cap screw (43) and pull the trunnion (17)
- Knock the trunnion (17) off with a piece of wood and a hammer, if needed
- Remove and discard trunnion O-ring (44) and trunnion gasket (42). There shall be no scratches or dent marks on sealing zones during this removal process.
- Remove the thrust washer (18) & trunnion bearing (19)
- Remove the ball (9) and place it on a soft surface

- Lift the ball (9) along with the trunnion plates (17) out of the body
- Place the ball on soft surface
- Remove the seat (10), seat retainer (14), socket head cap screws (84) if applicable, seat gasket (13), and springs (15 & 16) from body (1). Discard the seat O-rings/lip seals (11) (12), seat gasket (13). There shall be no scratches or dent marks on sealing zones during this process.
- Remove the trunnion plates (17) from the hubs of the ball (9)
- Remove trunnion bearing (19) and trunnion thrust washer (18/23) from trunnion (17). For Class 600, 900, 1500 rated valves, remove other side body caps & all associated parts as per above instructions.

4.7 Inspection of removed parts

- Clean all valve parts & bearings and ensure all dirt, grease, debris, etc. are completely removed
- See if the stem (21) and stem bearing (24) are damaged
- See if the trunnion thrust washer (18/23) and trunnion bearing (19) are damaged
- See if the ball (9) or seats (10) are damaged (scratched), by examining them under bright light. The ball and the seat can be replaced if necessary.
- See if the body joint, stem housing joint, and external trunnion joint sealing surfaces are damaged

4.8 Replacing parts

We recommend that soft material parts be replaced whenever the valve is dismantled for servicing. Other parts may be replaced if necessary. Always use genuine spare parts to ensure proper functioning of the valve (see section "Ordering spare parts").

4.9 Re-assembly of the valve

- Place the valve body (1) for Class 150 & 300, and body cap (2) for Class 600, 900, 1500 valves in the position such that end flange is at bottom. Use a level surface that will not scratch the body end flange. Ensure the body joint side is facing upward. Clamp the body firmly before proceeding further.
- Apply a thin film of anti-seize compound like 'Never Seez NS-160' or equivalent on all threaded surfaces of fasteners, fastener tapped holes in valve parts, nut bearing surfaces, stem to ball drive surface, and external mounting hardware power transmission surfaces (coupler drive square or keyway lateral surfaces or other similar zones) to prevent galling.
- Apply a thin film of Molykote-111 or equivalent silicone grease on O-rings, lip seals, graphite seals, gland packing, gaskets, and trunnion bearing surfaces for ease of assembly.
- Screw the studs (3) fully into the body (1) tapped holes that are at the body cap side
- Insert the springs (15 & 16) in to the spring pockets that are drilled in the body (1) or body cap (2) as applicable
- Install both the seat O-rings/Lip seals (12) on seat (10) and insert springs (15) in seat holes

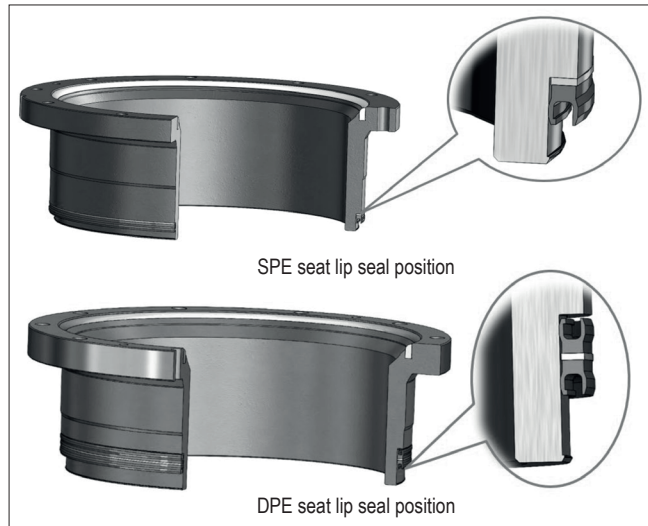

NOTE:

High density silicone grease can be used to hold the springs in hole to ensure they are not falling out during assembly process.

- Insert seat gasket (13) and seat retainer (14) on seat (10) by taking care of inclined sealing surface of seat gasket (13) and seat retainer (14)
- Hold the seat (10), seat gasket (13), seat retainer (14) with help of fixture and gently insert the assembly into the body (1) or body cap (2) seat pocket. For Class 600, 900, 1500 rated valves, install the heavy hex nuts (5) on the body cap (2) side.

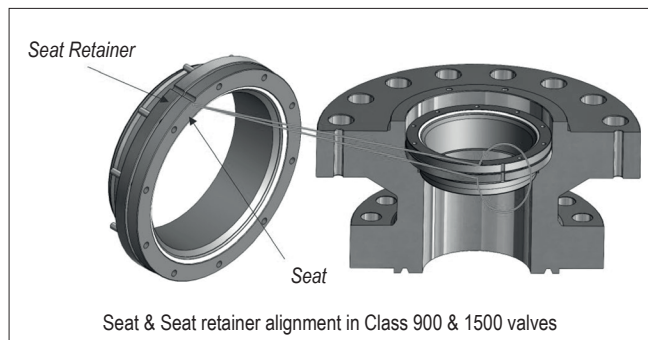

- For Class 900 & 1500 rated valves, install the seat retainer (14) into the body cap (2), confirming that the seat gasket (13) is correctly positioned and aligned with the seat pocket.
- Install socket head cap screws (84) into the seat retainer (14) and partially tighten them using an appropriate allen key
- Insert the seat (10) with the lip seal (11) into the body Cap (2), applying an evenly distributed load using a fixture. Ensure that the lip seal is not damaged during the process.
- Align the slots in seat (10) and seat retainer (14), and then tighten the socket head cap screws (89) to full tightness.

Only for NPS 2 & 3 Class 150 & 300

- Insert the ball (9) into the body (1) taking care that the drive is at stem side of the valve, and circular bottom side of ball is at trunnion (17)
- Insert springs (16) in the seat pocket holes of body cap (2)

NOTE:

High density silicone grease can be used to hold the springs in hole to ensure they are not falling out during assembly process.

- Insert seat gasket (13) and seat retainer (14) on seat (10) by taking care of inclined sealing surface of seat gasket (13) and seat retainer (14)
- Hold the seat (10), seat gasket (13), seat retainer (14) with help of fixture and gently insert the assembly into the body cap (2) seat pocket
- Install O-ring (11) and gasket (7) into the body cap (2). Assemble the body cap (2) along with seat assembly by matching fixed dowel pins (8) and pin holes.
- If applicable, lifting hooks (34) to be fitted in body joint
- Tighten the hex nuts (5) in crisscross pattern (refer Table-2)
- Install gasket (42), O-ring (44), bearing (19) and thrust washer (18) into the trunnion (17) and insert through body-trunnion bore until it touches to the bearing
- Fix the trunnion (17) on body (1) by screwing the cap screws (43)

For NPS 4 to 24 Class 150 & 300

- Place ball (9) on plane surface and apply thin film of Molykote-111 or equivalent silicone grease on the area where trunnion bearing (19), and trunnion thrust bearing (18) encounters the ball and trunnion plates (17)
- Assemble the trunnion thrust bearing (18) on upper and lower side of ball (9), and trunnion bearings (19) in both the trunnion plates (17)
- Assemble both the trunnion plates (17) on ball (9)
- Place the ball along with the trunnion plates inside the valve body (1) taking care of the stem side of the valve
- Locate the dowel pins (20) of trunnion plates (17) inside dowel pin holes of valve body (1)
- Insert springs (16) in the seat pocket holes of body cap (2)
- Install both the O-rings (11) (12) on seat (10) and insert springs (15) in seat pocket holes
- Insert seat gasket (13) and seat retainer (14) on seat (10) by taking care of inclined sealing surface of seat gasket (13) and seat retainer (14)
- Hold the seat (10), seat gasket (13) & seat retainer (14) with help of fixture and gently insert seat assembly into the body cap (2) seat pocket
- If applicable, tighten the locking plate with the help of socket head cap screws or hex bolts as per valve size (refer Table-2)
- Install O-ring (11) (12) and body gasket (7) into the body cap (2)
- Assemble the body cap (2) along with seat assembly by matching fixed dowel pins (8) and pin holes
- Lifting hooks (34) and mounting stands (35) to be fitted as applicable
- Tighten the body joint hex nuts (5) in crisscross pattern (refer Table-1 & 2)

For all valves

- Place the valve on stand in such way that the direction of the flow axis is horizontal
- Install the stem (21) inside the body (1). Ensure that across flat of the stem is aligned with the drive slot of the ball. Ensure stem keyway is on the body side.
- Insert stem thrust washer (23) on stem (21)

- Apply thin film of Molykote-111 or equivalent silicone grease on bearing & O-ring surfaces in stem housing (26)
- Install stem seal O-rings (22) in the stem housing (26) bore. Also install housing sealing O-ring (27) & gasket (28) on the stem housing (26).
- Place the stem bearing (24) and install it in stem housing (26)
- Locate both the dowel pins (30) in dowel holes of body (1) & place the stem housing (26) on the body (1)
- Insert the stem housing assembly through stem (21) & fix it with body (1) by bolting (29)
- For gland packing assembly, please refer section 4.2
- Apply thin film of PTFE based thread sealant LOCTITE 567 or equivalent on the threaded surfaces of the drainage connection (38), grease fitting (39), bleeder valve (40), internal check valve (53) if applicable, and then screw them in to the respective ports of valve.
- Wherever applicable, fix the internal check valve (53) and/or grease fitting (39) along with connector (45) on stem housing and body (1) & body cap (2)

Table 5 NPT (as per ASME B1.20.1) thread tightening torques

Thread size	Max. torque	
	ft-lbs	N-m
¼" NPT	20	28
½" NPT	50	68
¾" NPT	55	75
1" NPT	65	88

Alternative method for NPT thread tightening: Hand tight 2-3 turns followed by wrench tightening 1-2 turns, and then check the tightness during hydrostatic shell test. Over application of torque on threads can cause damage.

5. TESTING THE VALVE

CAUTION:

Valves with Auxiliary connections - all drain, vent, and sealant injection lines shall be subjected to shell hydrostatic test along with the valve. When external relief valves are used, those points shall be blind plugged during shell hydrostatic test. Such external relief valves shall be installed after shell hydrostatic test. Sealant injection ports that are equipped with internal check or non-return valve (NRV) (53) shall be tested without the injection fitting. When more than one NRV are used, then only the primary sealing barrier NRV shall be installed during shell hydrostatic test. Up on successful completion of shell test, additional NRVs, injection fittings, external relief valve, etc. shall be installed.

We recommend that the valve body be pressure tested after the valve has been assembled. The pressure test should be carried out in accordance with an applicable standard (e.g., ASME B16.34, API 6D, API 598, etc.) using the pressure rating required by the pressure class or flange rating of the valve. The valve must be in an half-open position during the test. If you also want to test the tightness of the closure member, contact the manufacturer for instructions.

6. INSTALLING THE ACTUATOR

6.1 General

CAUTION:

Beware of ball cutting movement!

Different Neles actuators can be mounted using suitable mounting hardware. The valve can be actuated by an manual operator or pneumatic actuator or actuators of any other type / make.

6.2 Installing manual operators (MGR series)

- Refer to Valmet publication IMO-554EN for Installation, maintenance and operating instructions of MGR series gears
- Ensure valve stem key (25) is installed in the keyway
- Turn the valve to the closed position
- Apply thin film of Neverseez NS-160 or equivalent anti-seize compound in the MGR gear bottom drive connection
- Insert the coupler (part of mounting hardware) on the stem (21) by aligning the with the stem key (25) and keyway of coupler
- Install a mounting bracket through coupler (63) and fasten the bracket with valve body using correct bolting, spring washers / split washer as applicable
- Insert the key in a coupler keyway, if applicable
- Mount the MGR gears on top of mounting bracket & fasten it using correct bolting, spring washers / split washer as applicable
- After installation of the gear, it is then necessary to adjust the travel stops for the proper full-open and full-close valve position (see Figure 17)

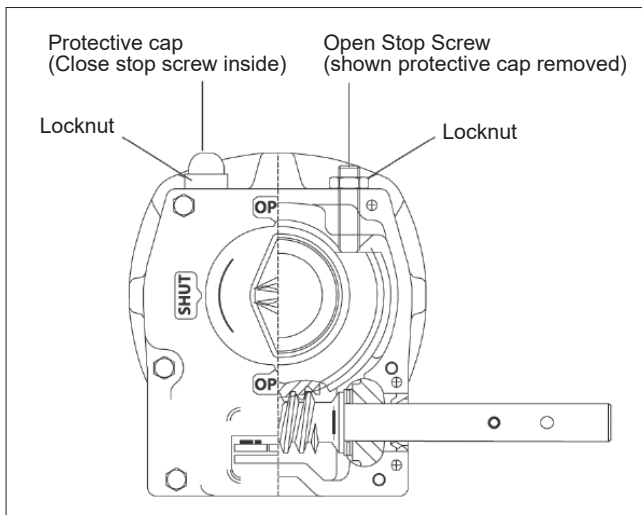

Fig. 17 Travel stop adjustment

- To adjust either stop screw, the protective plastic cap must be removed and the locknut must first be loosened. Turning either screw in reduces valve travel. Turning either screw out increases valve travel
- Back off the screw, if necessary, turn the valve to the correct open or closed position, then turn the stop screw until it contacts the gear segment. While holding the screw to prevent it from turning, tighten the locknut.

- Fully cycle the actuator and valve in both directions by turning the handwheel. Check that the proper open and closed positions are achieved and that the indicator pointer is indicating correctly, i.e., closed when the valve is closed. Rework and readjust as needed. Replace the protective cap.

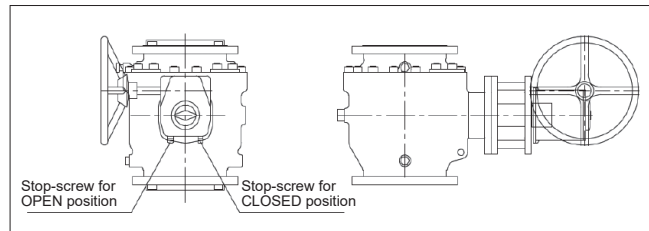

Fig. 18 Manual operator mounting

6.3 Installing pneumatic actuators (B1 series)

- Refer to Valmet publication 6BJ71EN & 6BC71EN for Installation, maintenance and operating instructions of B1 series actuators
- Ensure valve stem key (25) is installed in the keyway
- Turn the valve to the closed position
- Apply thin film of Neverseez NS-160 or equivalent anti-seize compound in the B1 actuator bottom drive connection
- Insert the coupler (part of mounting hardware) on the stem (21) by aligning the with the stem key (25) and keyway of coupler
- Install a mounting bracket through coupler (63) and fasten the bracket with valve body using correct bolting, spring washers / split washer as applicable
- Insert the key in a coupler keyway, if applicable
- Mount the B1 actuator on top of mounting bracket & fasten it using correct bolting, spring washers / split washer as applicable
- After installation of the actuator, it is then necessary to adjust the travel stops for the proper full-open and full-close valve position (see Figure 19, 20, 21)

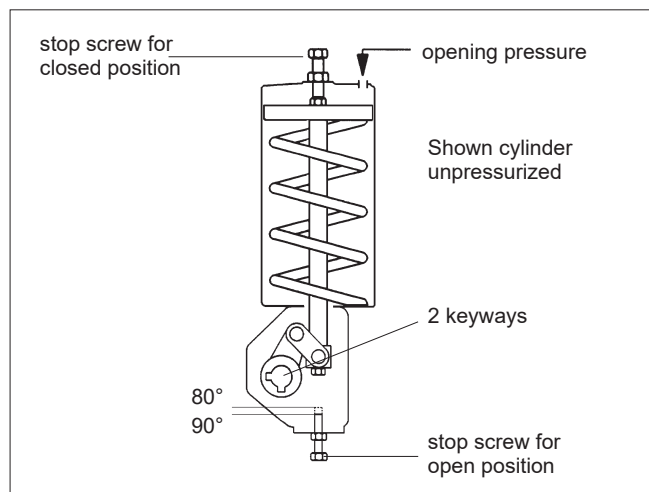

Fig. 19 Example of spring-to-close pneumatic actuator stop screw adjustment in B1J series

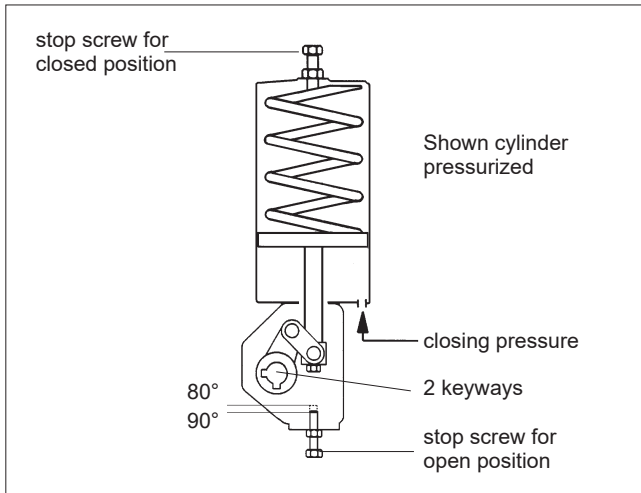

Fig. 20 Example of spring-to-open pneumatic actuator stop screw adjustment in B1J series

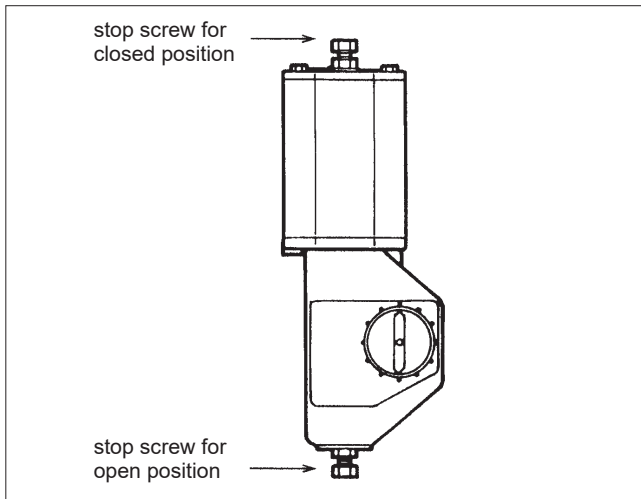
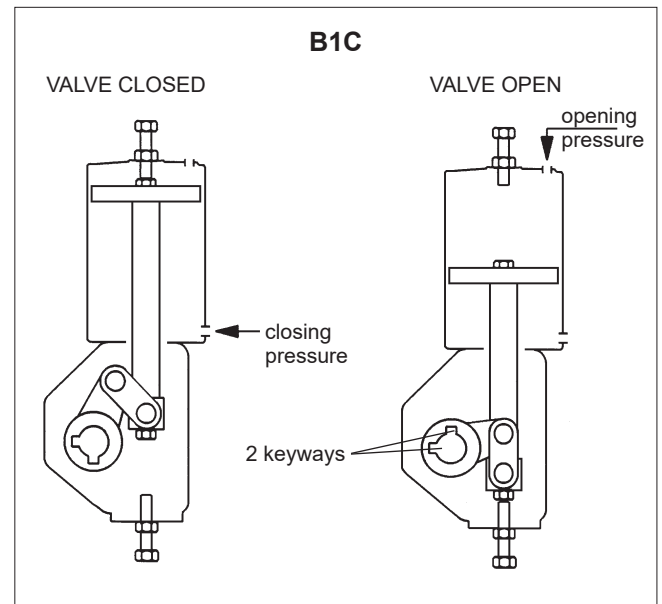
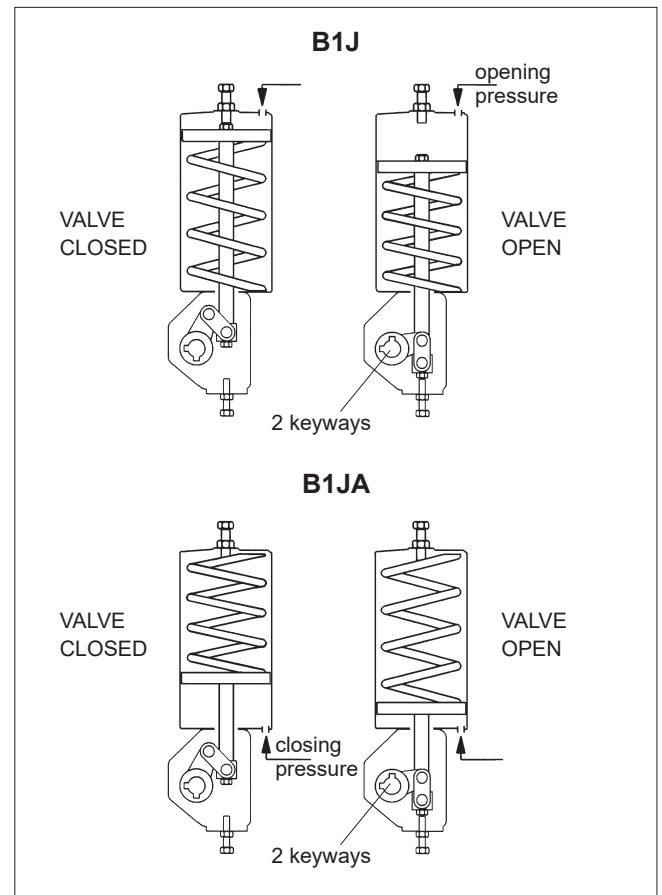

Fig. 21 Example of double acting pneumatic actuator stop screw adjustment in B1C series

Operating principle of B1 series



6.4 Installing other makes of actuators

NOTE:

Valmet accepts no responsibility for compatibility of actuators not installed by Valmet.

7. TROUBLE SHOOTING

The following table lists malfunctions that might occur after prolonged use.

NOTE:

There may be cases where the user has pumped emergency sealant through the sealant injection grease fitting (39). Such sealants only provides temporary leak protection until next available maintenance schedule.

CAUTION:

Valve should not be operated after emergency sealant is used. Servicing must be done as early as possible in such cases.

NOTE:

Each valve can be application specific, many factors should be considered when selecting a valve for a given application. Therefore, some of the applications in which the valves are used are outside the scope of this document. If you have any questions concerning the use, application or compatibility of the valve with the intended service, contact nearest Valmet sales office for more information.

Symptom	Possible fault	Recommended action
Seat leakage through a closed valve	Wrong stop screw adjustment of the actuator	Adjust the stop screw for closed position
	Faulty zero setting of the controller	Adjust the controller
	Damaged seat	Replace seat
	Damaged closing member	Replace the closing member
	Closing member in a wrong position relative to the actuator	Select the correct keyway in the actuator
Leakage through body joint or drainage / bleeder connection	Damaged gasket	Replace the gasket
	Loose joint	Tighten the nuts or screws
Irregular or no valve movement	Actuator or positioner malfunction	Check the operation of the actuator and positioner
	Process medium accumulated on the sealing surface	Clean the sealing surfaces
	Closing member or seat damaged	Replace the closing member or seat
	Crystallizing medium has entered the bearing spaces	Flush the bearing spaces
Leakage through stem seal	Gland packing worn or damaged	Tighten the gland packing or replace the gland packing or inject emergency sealant

8. TOOLS

In addition to standard tools, the following special tools might be needed when B-series actuator is used on the valve.

- For removal of the actuator:
 - extractor (ID-code table in actuator's IMO)

9. ORDERING SPARE PARTS

When ordering spare parts, always include the following information:

- Type code, sales order number, serial number
- number of the parts list, part number, name of the part and quantity required

This information can be found from the name plate or documents.

10. EXPLODED VIEW AND PARTS LIST

10.1 NPS 2 & 3 ASME Class 150 & 300

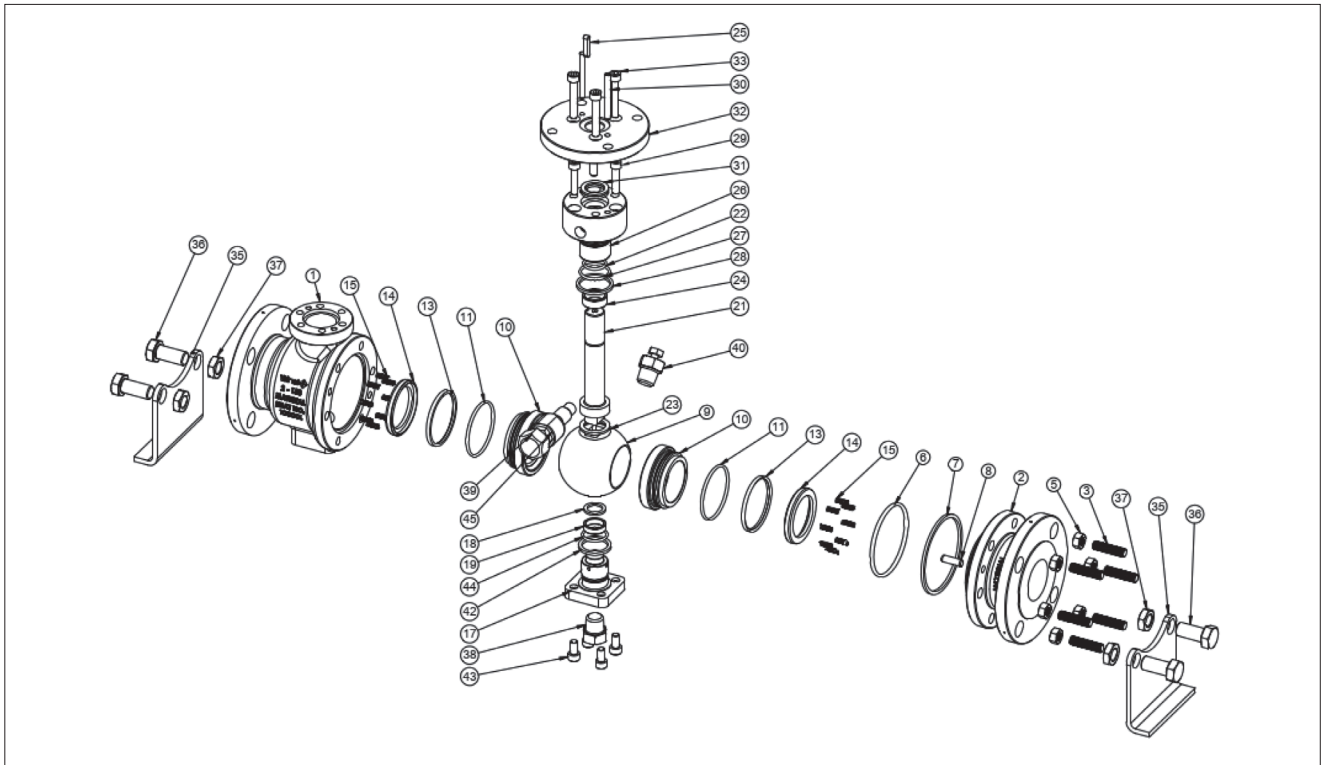

Item	Qty	Description	Spare part category
1	1	Body	
2	1	Body cap	
3		Stud	
5		Heavy Hex Nut	
6	1	O-ring	1
7	1	Gasket	1
8	2	Dowel Pin	
9	1	Ball	3
10	2	Seat	2
11	2	O-Ring	1
13	2	Seat Gasket	1
14	2	Seat Retainer	
15		Spring	2
17	1	Trunnion	
18	1	Thrust Washer	3
19	1	Bearing	3
21	1	Stem	3
22	2	O-Ring	1
23	1	Thrust Washer (Stem seal)	1
24	1	Bearing	3
25	1	Key	3
26	1	Stem Housing (Bonnet)	
27	1	O-Ring	1
28	1	Gasket	1
29		Cap Screw	
30	2	Dowel Pin	
31	2	Gland Packing	1
32	1	Mounting Flange (Gland)	
33		Cap Screw	
35	2	Mounting Stand	
36		Bolt	
37		Nut	
38	1	Drainage Connection	
39	1	Grease Fitting	
40	1	Bleeder Valve	
42	1	Gasket	1
43		Cap Screw	
44	1	O-ring	1
45	1	Connector	

Spare part (Spare Part Set): Recommended soft parts, always needed for the repair. Delivered as a set.

Spare part category 1: Soft parts

Spare part category 2: Parts for replacing of the seat. Available also as a set.

Spare part category 3: Parts for replacing of the closing element

Spares for the full overhaul: All parts from the categories 1, 2 and 3.

10.2 NPS 4 to 24 ASME Class 150 & 300

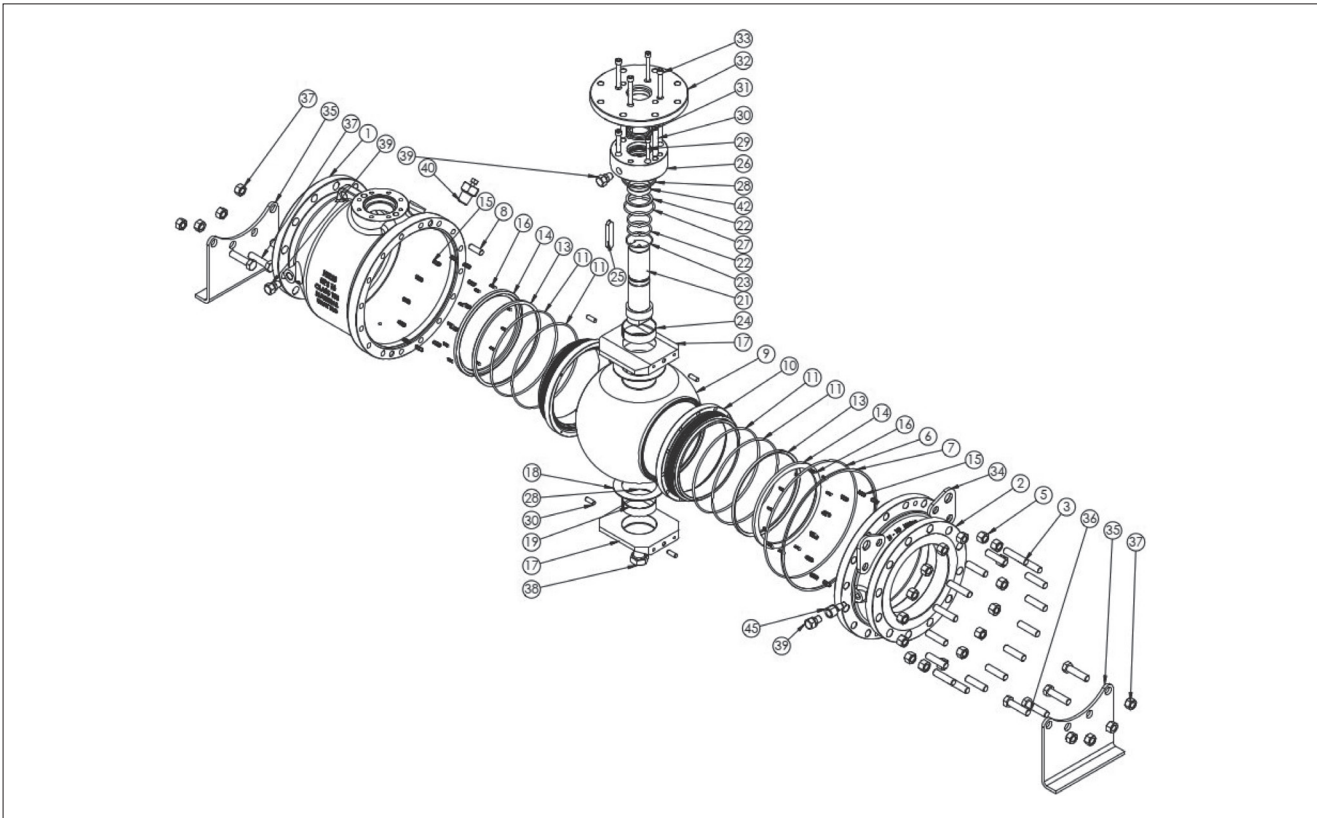

Item	Qty	Description	Spare part category
1	1	Body	
2	1	Body cap	
3		Stud	
5		Heavy Hex Nut	
6	1	O-ring	1
7	1	Gasket	1
8	2	Dowel Pin	
9	1	Ball	3
10	2	Seat	2
11	2	O-Ring	1
13	2	Seat Gasket	1
14	2	Seat Retainer	
15		Spring	2
16		Spring	2
17	2	Trunnion (Trunnion plate)	
18	2	Thrust Washer	3
19	2	Bearing	3
20	4	Dowel Pin	
21	1	Stem	3
22	2	O-Ring	1
23	1	Thrust Washer (Stem seal)	1
24	1	Bearing	3
25	1	Key	3
26	1	Stem Housing (Bonnet)	
27	1	O-Ring	1
28	1	Gasket	1
29		Cap Screw	
30	2	Dowel Pin	
31	2	Gland Packing	1
32	1	Mounting Flange (Gland)	
33		Cap Screw	
34	2	Lifting Hook	
35	2	Mounting Stand	
36		Bolt	
37		Nut	
38	1	Drainage Connection	
39	3	Grease Fitting	
40	1	Bleeder Valve	
45	1	Connector	
53	2	Internal check valve	

10.3 NPS 2 to 24 ASME Class 600

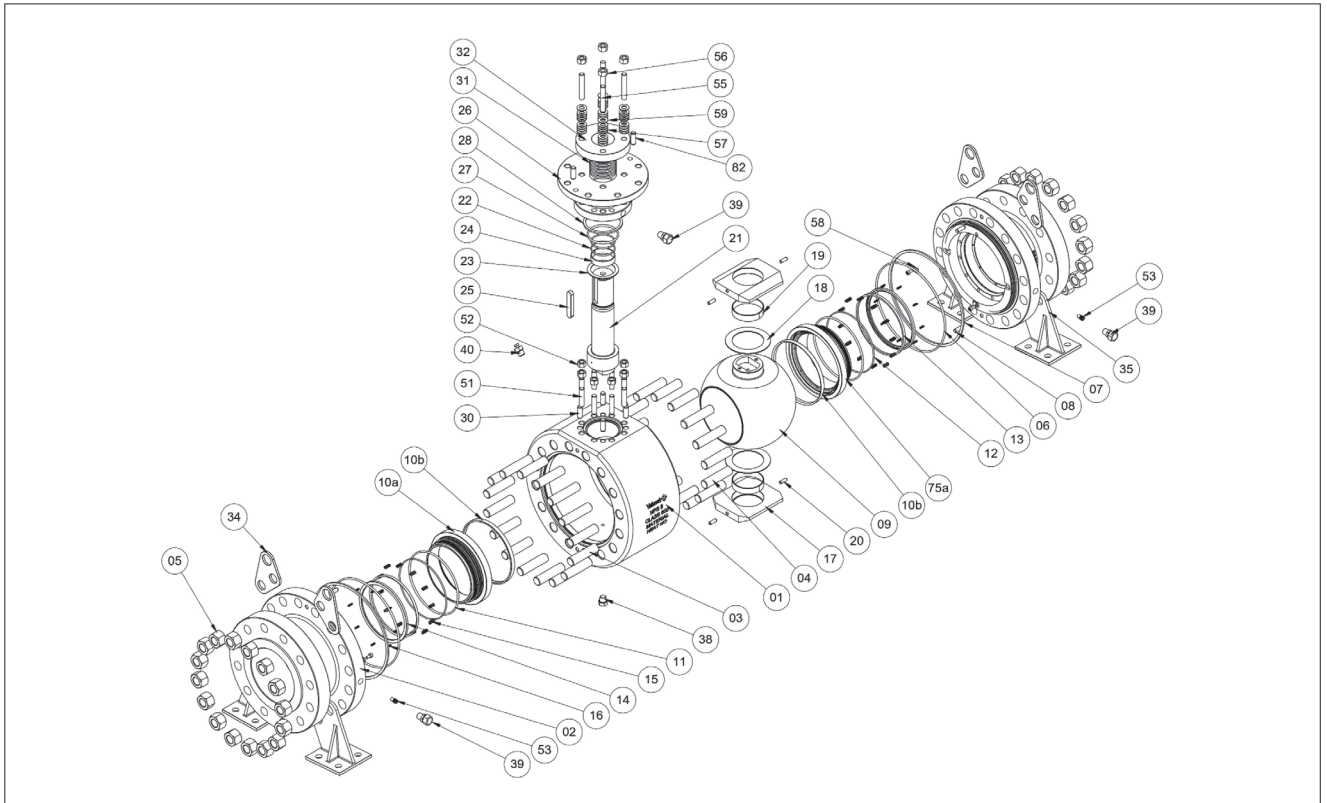

Item	Qty	Part Description	Spare part category
1	1	Body	
2	2	Body cap	
3, 4		Stud	
5		Heavy Hex Nut	
6	2	O-ring	1
7	2	Gasket	1
8		Dowel Pin	
9	1	Ball	3
10	2	Seat	2
11	2	O-Ring	1
12	2	O-Ring	1
13	2	Seat Gasket	1
14	2	Seat Retainer	
15		Spring	2
16		Spring	2
17	2	Trunnion (Trunnion plate)	
18	2	Thrust Washer	3
19	2	Bearing	3
20		Dowel Pin	
21	1	Stem	3
22	2	O-Ring	1
23	1	Thrust Washer (Stem seal)	1
24	1	Bearing	3
25	1	Key	3
26	1	Stem Housing (Bonnet)	
27	1	O-Ring	1
28	1	Gasket	1
30		Dowel Pin	
31	1 set	Gland Packing	1
32	1	Gland	
34	4	Lifting Hook	
35	2	Mounting Stand	
38	1	Drainage Connection	
39	3	Grease Fitting	
40	1	Bleeder Valve	
42		Connector	
51		Stud	
52		Hex Nut	
53	3	Internal Check Valve	
55		Stud	
56		Heavy Hex Nut	
57		Disc spring (live loading)	
58		Socket head cap screw	
59		Flat washer	
82		Dowel Pin	

10.4 NPS 2 to 12 ASME Class 900 & 1500

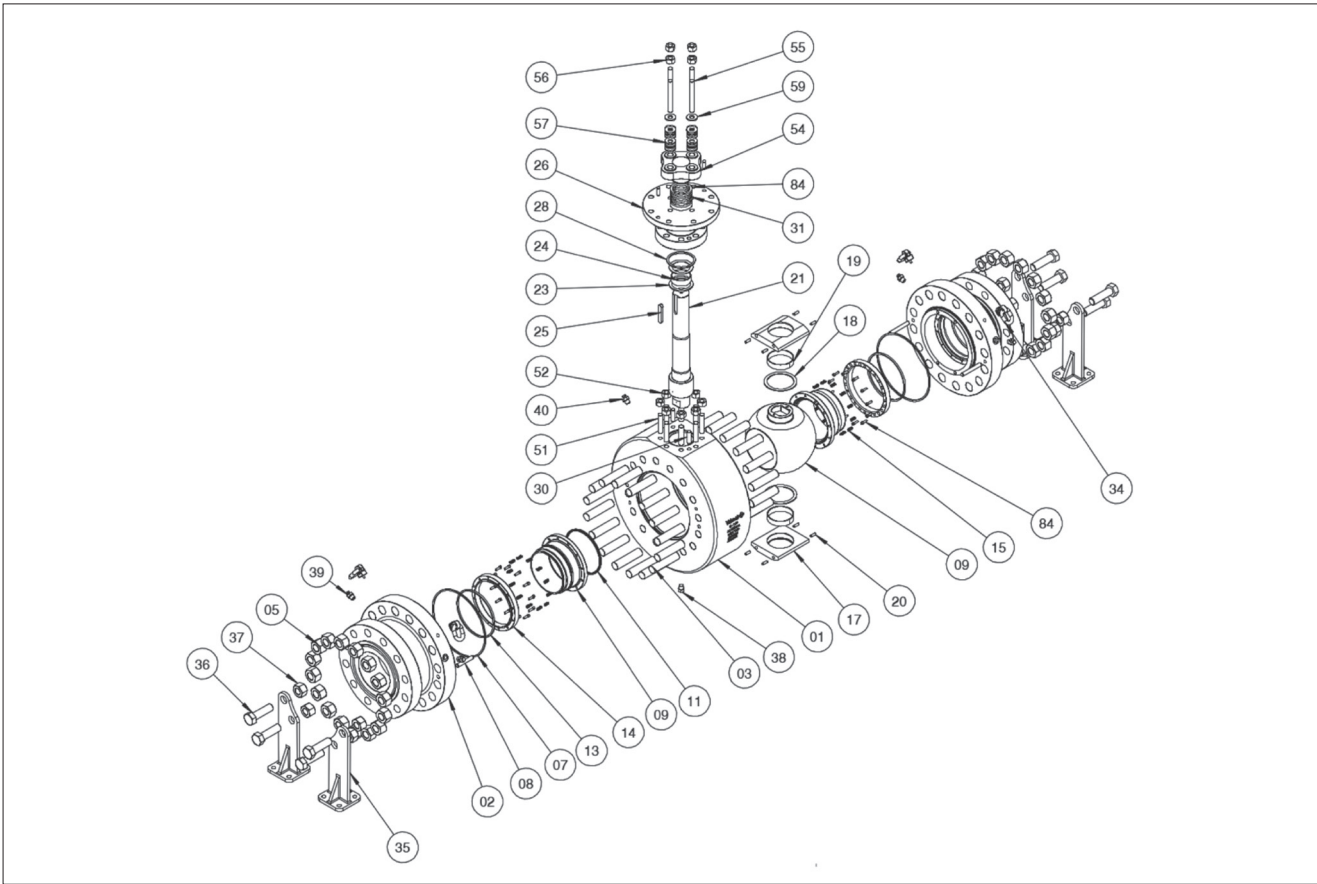

Part No	Qty	Part Name	Spare Part Category
1	1	Body	
2	2	*Body cap	
3		Stud	
5		Nut	
7	2	Gasket	1
8	2	Dowel Pin	
9	1	Ball	3
10	2	Seat	2
11	2	Lip Seal	1
13	2	Seat Gasket	1
14	2	Seat Retainer	
15		Springs	2
17	2	Trunnion (Trunnion plate)	
18	2	Thrust Washer	3
19	2	Bearing	3
20	4	Dowel Pin	
21	1	Stem	3
23	1	Thrust Washer (Stem seal)	1
23A	1	Thrust Washer (Stem seal)	1
24	1	Bearing	3
25	1	Key	3

Part No	Qty	Part Name	Spare Part Category
26	1	Stem Housing (Bonnet)	
28	1	Gasket	1
30	2	Dowel Pin	
31	1 Set	Gland Packing	1
34	4	Lifting eye bolt	
35		Mounting Stand	
36		Bolt	
37		Nut	
38	1	Drainage Connection	
39	4	#Grease Fitting	
40	1	Bleeder Valve	
51		Stud	
52		Nut	
53	4	#Internal check valve	
54	1	Gland	
55		Stud	
56		Nut	
57		Disc Spring (live loading)	
59		Flat Washer	
84		Socket Head Cap Screw	
89	1	Anti Extrusion Ring	

*Lip seal contact surfaces in Carbon & Alloy steel valves are with corrosion resistant SS316L overlay as standard

#Optional feature, to be selected if required

11. DIMENSIONS & WEIGHT

11.1 Bare valve

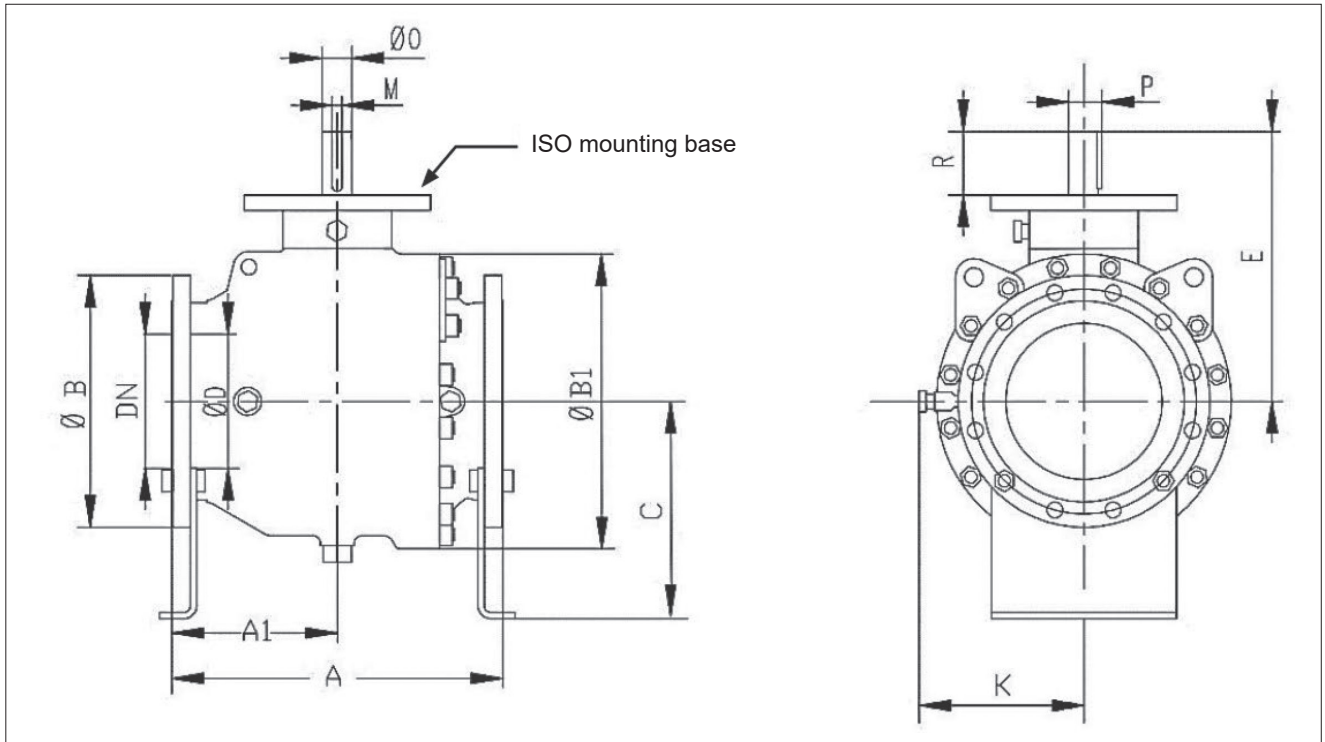

Note: Valve face-to-face dimension acc. to Table C-2 of API 6D

SI units

ASME Class 150

NPS	DIMENSIONS, mm												WEIGHT kg	ISO 5211
	A	A1	ØB	ØB1	C	ØD	E	K	M	ØO	P	R		
2	178	84	152	136.5	131	49	172	125	6	22	24.5	34	21	F10
3	203	94.5	190	180	164	74	206.5	170	12	30	33	43.5	37	F12
4	229	114.5	229	230	181	100	243	170	10	38	41	55	53	F12
6	394	197	279	324	210	150	292.5	170	14	45	48.5	62.5	153	F16
8	457	228.5	343	403	313	201	381	250	18	60	64	80	257	F25
10	533	266.5	406	475	350	252	437.5	275	18	64	68	105	380	F25
12	610	305	483	566	410	303	489	345	20	73	77.5	114	575	F25
14	686	343	533	631	400	334	525.5	350	25	87	90	130.5	795	F25
16	762	381	597	726	500	385	615	415	25	92	97	153.5	1195	F30
18	864	432	635	800	500	436	689.5	435	28	100	106	158	1410	F30
20	914	457	698	900	570	487	715	485	32	110	117	172.5	1850	F30
24	1067	533.5	813	1040	620	589	860	550	32	122	129	220	2800	F35

ASME Class 300

NPS	DIMENSIONS, mm												WEIGHT kg	ISO 5211
	A	A1	ØB	ØB1	C	ØD	E	K	M	ØO	P	R		
2	216	103	165	136.5	116	49	172	125	6	22	24.5	34	25	F10
3	283	137.5	210	190	182	74	206.5	170	12	30	33	43.5	52	F12
4	305	142.5	254	236	156	100	243	170	10	38	41	55	76	F12
6	403	201.5	318	338	228.5	150	292.5	170	14	45	48.5	62.5	182	F16
8	502	251	381	420	315	201	381	280	18	60	64	80	340	F25
10	568	284	444	490	360	252	437.5	310	18	64	68	105	460	F25
12	648	324	521	587	410	303	489	350	20	73	77.5	114	690	F25
14	762	381	584	631	400	334	525.5	350	25	87	90	130.5	850	F25
16	838	435.8	648	740	500	385	615	420	25	92	97	153.5	1205	F30
18	914	457	711	822	500	436	689.5	445	28	100	106	158	1645	F30
20	991	495.5	775	920	570	487	715	495	32	110	117	172.5	2255	F30
24	1143	571.5	914	1070	620	589	860	550	32	122	130	220	3430	F35

Imperial units
ASME Class 150

NPS	DIMENSIONS, inch												WEIGHT lbs	ISO 5211
	A	A1	ØB	ØB1	C	ØD	E	K	M	ØO	P	R		
2	7.01	3.31	5.98	5.37	5.16	1.93	6.77	4.92	0.24	0.87	0.96	1.34	46	F10
3	7.99	3.72	7.48	7.09	6.46	2.91	8.13	6.69	0.47	1.18	1.30	1.71	82	F12
4	9.02	4.51	9.02	9.06	7.13	3.94	9.57	6.69	0.39	1.50	1.61	2.17	117	F12
6	15.51	7.76	10.98	12.76	8.27	5.91	11.52	6.69	0.55	1.77	1.91	2.46	337	F16
8	17.99	9.00	13.50	15.87	12.32	7.91	15.00	9.84	0.71	2.36	2.52	3.15	567	F25
10	20.98	10.49	15.98	18.70	13.78	9.92	17.22	10.83	0.71	2.52	2.68	4.13	838	F25
12	24.02	12.01	19.02	22.28	16.14	11.93	19.25	13.58	0.79	2.87	3.05	4.49	1268	F25
14	27.01	13.50	20.98	24.84	15.75	13.15	20.69	13.78	0.98	3.43	3.54	5.14	1753	F25
16	30.00	15.00	23.50	28.58	19.69	15.16	24.21	16.34	0.98	3.62	3.82	6.04	2635	F30
18	34.02	17.01	25.00	31.50	19.69	17.17	27.15	17.13	1.10	3.94	4.17	6.22	3109	F30
20	35.98	17.99	27.48	35.43	22.44	19.17	28.15	19.09	1.26	4.33	4.61	6.79	4079	F30
24	42.01	21.00	32.01	40.94	24.41	23.19	33.86	21.65	1.26	4.80	5.08	8.66	6173	F35

ASME Class 300

NPS	DIMENSIONS, inch												WEIGHT lbs	ISO 5211
	A	A1	ØB	ØB1	C	ØD	E	K	M	ØO	P	R		
2	8.50	4.06	6.50	5.37	4.57	1.93	6.77	4.92	0.24	0.87	0.96	1.34	55	F10
3	11.14	5.41	8.27	7.48	7.17	2.91	8.13	6.69	0.47	1.18	1.30	1.71	115	F12
4	12.01	5.61	10.00	9.29	6.14	3.94	9.57	6.69	0.39	1.50	1.61	2.17	168	F12
6	15.87	7.93	12.52	13.31	9.00	5.91	11.52	6.69	0.55	1.77	1.91	2.46	401	F16
8	19.76	9.88	15.00	16.54	12.40	7.91	15.00	11.02	0.71	2.36	2.52	3.15	750	F25
10	22.36	11.18	17.48	19.29	14.17	9.92	17.22	12.20	0.71	2.52	2.68	4.13	1014	F25
12	25.51	12.76	20.51	23.11	16.14	11.93	19.25	13.78	0.79	2.87	3.05	4.49	1521	F25
14	30.00	15.00	22.99	24.84	15.75	13.15	20.69	13.78	0.98	3.43	3.54	5.14	1874	F25
16	32.99	17.16	25.51	29.13	19.69	15.16	24.21	16.54	0.98	3.62	3.82	6.04	2657	F30
18	35.98	17.99	27.99	32.36	19.69	17.17	27.15	17.52	1.10	3.94	4.17	6.22	3627	F30
20	39.02	19.51	30.51	36.22	22.44	19.17	28.15	19.49	1.26	4.33	4.61	6.79	4971	F30
24	45.00	22.50	35.98	42.13	24.41	23.19	33.86	21.65	1.26	4.80	5.12	8.66	7562	F35

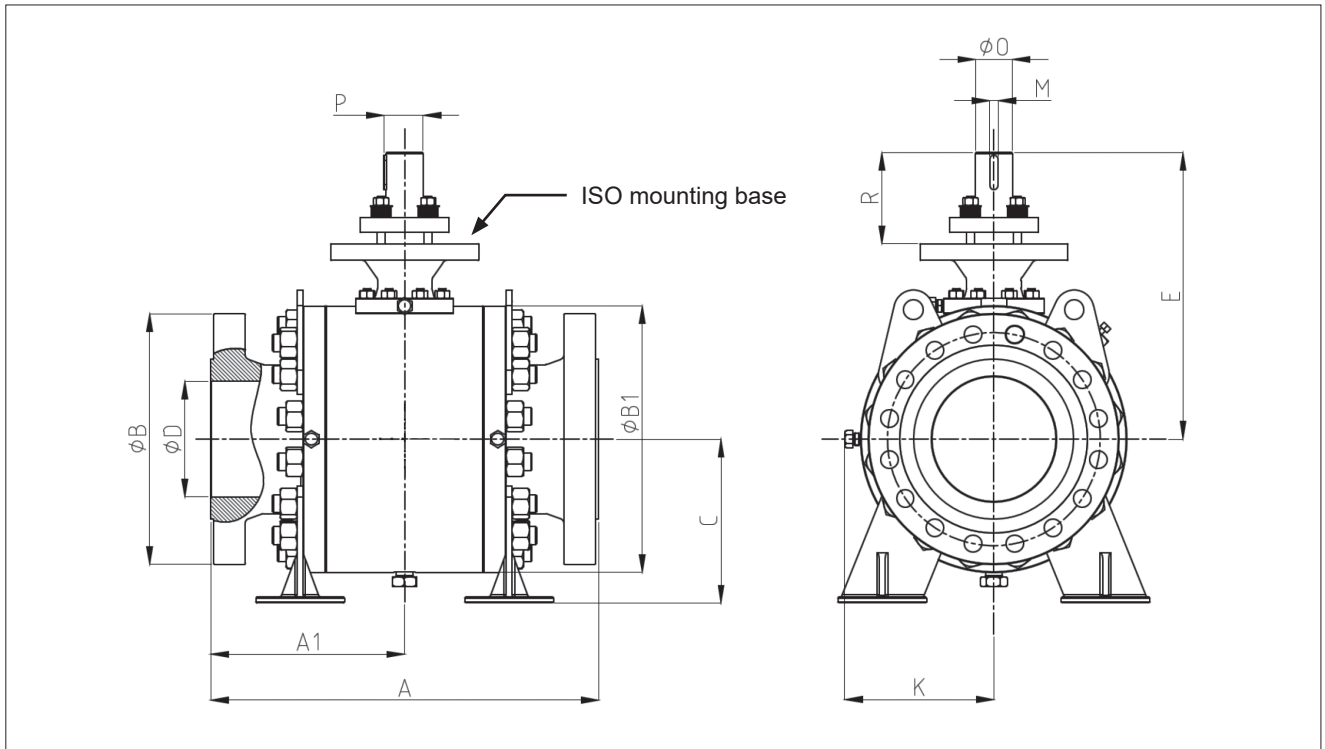

Note: Valve face-to-face dimension acc. to Table C-2 of API 6D

SI units

ASME Class 600

NPS	DIMENSIONS, mm												WEIGHT kg	ISO 5211
	A	A1	B	B1	C	D	E	K	M	ØO	P	R		
2	292	146	165	180	125	49	235.5	-	6	22	24.5	83.5	40	F10
3	356	178	210	225	155	74	299.5	142	8	26	29	107	74	F12
4	432	216	273	314	205	100	356	172	12	40	43	105.5	160	F16
6	559	279.5	356	370	240	150	451.5	220	14	45	48.5	158.5	290	F16
8	660	330	419	500	308	201	557.5	261	20	70	74.5	200.5	545	F25
10	787	393.5	508	540	332	252	580.5	304	20	75	79.5	184.5	800	F25
12	838	419	559	635	442	303	658	345	22	80	85	206	1130	F25
14	889	444.5	603	705	412	334	717	385	22	85	90	234.5	1490	F30
16	991	495.5	686	780	495	385	749.5	425	22	85	90	234.5	1980	F30
18	1092	546	743	870	555	436	847	468	25	90	95	252	2640	F35
20	1194	597	813	960	565	487	884	514	28	100	106	238.5	3345	F35
24	1397	698.5	940	1120	715	589	1009	593	32	120	127	259	5100	F40

Imperial units

ASME Class 600

NPS	DIMENSIONS, inch												WEIGHT lbs	ISO 5211
	A	A1	B	B1	C	D	E	K	M	ØO	P	R		
2	11.5	5.75	6.50	7.09	4.92	1.93	9.27	-	0.24	0.87	0.96	3.29	88	F10
3	14.0	7.0	8.25	8.86	6.10	2.91	11.79	5.59	0.31	1.02	1.14	4.21	163	F12
4	17.0	8.5	10.75	12.36	8.07	3.94	14.02	6.77	0.47	1.57	1.69	4.15	353	F16
6	22.0	11	14.00	14.57	9.45	5.91	17.78	8.66	0.55	1.77	1.91	6.24	639	F16
8	26.0	13	16.50	19.69	12.13	7.91	21.95	10.28	0.79	2.76	2.93	7.89	1202	F25
10	31.0	15.5	20.00	21.26	13.07	9.92	22.85	11.97	0.79	2.95	3.13	7.26	1764	F25
12	33.0	16.5	22.00	25.00	17.40	11.93	25.91	13.58	0.87	3.15	3.35	8.11	2492	F25
14	35.0	17.5	23.75	27.76	16.22	13.15	28.23	15.16	0.87	3.35	3.54	9.23	3285	F30
16	39.0	19.5	27.00	30.71	19.49	15.16	29.51	16.73	0.87	3.35	3.54	9.23	4366	F30
18	43.0	21.5	29.25	34.25	21.85	17.16	33.35	18.43	0.98	3.54	3.74	9.92	5821	F35
20	47.0	23.5	32.00	37.80	22.24	19.17	34.80	20.24	1.10	3.94	4.17	9.39	7376	F35
24	51.0	25.5	37.00	44.09	28.15	23.19	39.72	23.35	1.26	4.72	5.00	10.20	11246	F40

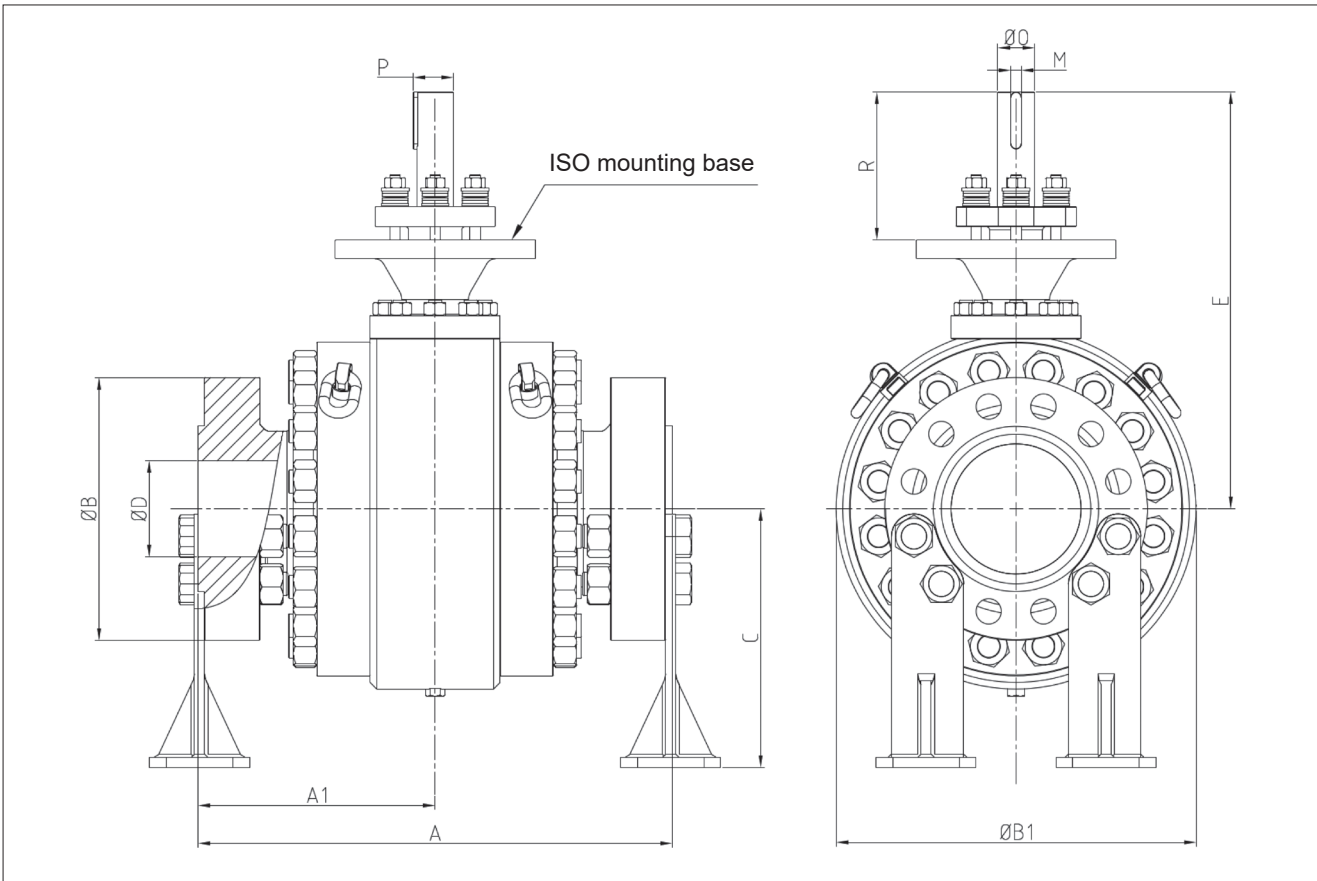

Note: Valve face-to-face dimension acc. to Table C-2 of API 6D

SI units

ASME Class 900

NPS	DIMENSIONS, mm											WEIGHT kg	ISO 5211
	A	A1	ØB	C	ØD	E	ØB	M	ØO	P	R		
2	368	184	216	177	49	368	250	8	28	31	143	89	F12
3	381	190.5	241	205	74	436.5	350	10	35	38	147	178	F16
4	457	228.5	292	260	100	486	400	12	43	46	174.5	279	F16
6	610	305	381	380	150	591	540	16	55	57.5	188	654	F25
8	737	368.5	470	436.1	201	743	680	20	75	79.5	248	1155	F30
10	838	419	546	525.9	252	879.5	850	22	80	83	267.5	2302	F30
12	965	482.5	610	625	303	1039.5	920	25	86	91	367.5	3144	F35

ASME Class 1500

NPS	DIMENSIONS, mm											WEIGHT kg	ISO 5211
	A	A1	ØB	C	ØD	E	ØB	M	ØO	P	R		
2	368	184	216	177	49	368	250	8	28	31	143	89	F12
3	470	235	267	260	74	436.5	350	10	35	38	147	227	F16
4	546	273	311	260	100	486	400	12	43	46	174.5	320	F16
6	705	352.5	394	387.34	144	591	540	16	55	57.5	188	787	F25
8	832	416	483	436.1	192	743	680	20	75	79.5	248	1446	F30
10	991	495.5	584	538.7	239	879.5	850	22	80	83	267.5	2606	F30
12	1130	565	673	624.75	287	1039.5	920	25	86	91	367.5	3640	F35

Imperial units

ASME Class 900

NPS	DIMENSIONS, inch											WEIGHT lbs	ISO 5211
	A	A1	ØB	C	ØD	E	ØB	M	ØO	P	R		
2	14.50	7.25	8.50	6.97	1.93	14.49	9.84	0.31	1.10	1.22	5.63	196	F12
3	15.00	7.50	9.50	8.07	2.91	17.19	13.78	0.39	1.38	1.50	5.79	392	F16
4	18.00	9.00	11.50	10.24	3.94	19.13	15.74	0.47	1.69	1.81	6.87	615	F16
6	24.00	12.00	15.00	14.96	5.91	23.27	21.26	0.63	2.17	2.26	7.40	1442	F25
8	29.00	14.50	18.50	17.17	7.91	29.25	26.78	0.79	2.95	3.13	9.76	2546	F30
10	33.00	16.50	21.50	20.70	9.92	34.63	33.46	0.87	3.15	3.27	10.53	5075	F30
12	38.00	19.00	24.00	24.61	11.93	40.93	36.22	0.98	3.39	3.58	14.47	6931	F35

ASME Class 1500

NPS	DIMENSIONS, inch											WEIGHT lbs	ISO 5211
	A	A1	ØB	C	ØD	E	ØB	M	ØO	P	R		
2	14.50	7.25	8.50	6.97	1.93	14.49	9.84	0.31	1.10	1.22	5.63	196	F12
3	18.50	9.25	10.50	10.24	2.91	17.19	13.78	0.39	1.38	1.50	5.79	500	F16
4	21.50	10.75	12.25	10.24	3.94	19.13	15.74	0.47	1.69	1.81	6.87	705	F16
6	27.75	13.88	15.50	15.25	5.67	23.27	21.26	0.63	2.17	2.26	7.40	1735	F25
8	32.75	16.38	19.00	17.17	7.55	29.25	26.78	0.79	2.95	3.13	9.76	3187	F30
10	39.00	19.50	23.00	21.21	9.41	34.63	33.46	0.87	3.15	3.27	10.53	5745	F30
12	44.50	22.25	26.50	24.60	11.30	40.93	36.22	0.98	3.39	3.58	14.47	8025	F35

11.2 Valve with manual operator

MGR Series

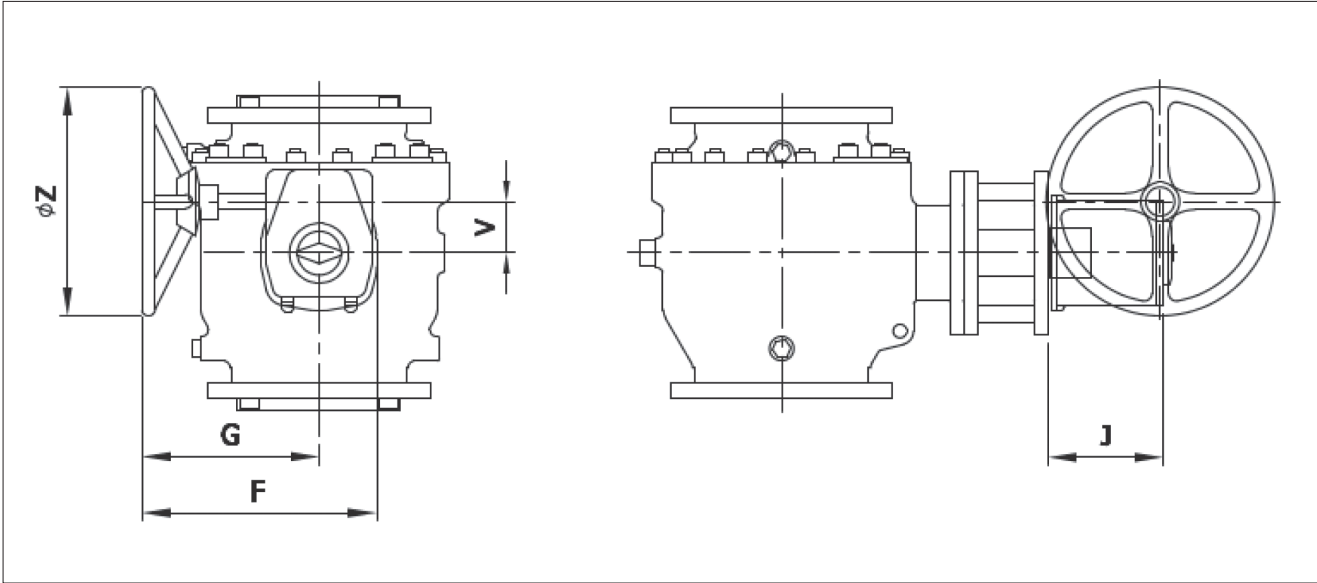

SI units

ASME Class 150

NPS	Gear	ISO Mounting	Dimensions, mm					WEIGHT kg
			F	G	J	V	øZ	
2	MGR 5/QA	F05	255	226	56	42	102	23
3	MGR 5/QA	F05	255	226	56	42	102	39
4	MGR7/QA	F07	268	217	61	52	200	57
6	MGR10/QA	F10	303	252	61	52	305	157
8	MGR12/QA	F14	369	304	87	71	508	266
10	MGR14/QA	F16	381	306	92	86	813	394
12	MGR14/QA	F16	381	306	92	86	813	589
14	MGR16/QA	F25	422	348	119	53	813	819
16	MGR16/QA	F25	422	348	119	53	813	1219
18	MGR20/K85A	F25	539	430	131	140	610	1459
20	MGR20/K85A	F25	539	430	131	140	610	1899
24	MGR30/K105A	F30	620	470	131	182	711	2864

ASME Class 300

NPS	Gear	ISO Mounting	Dimensions, mm					WEIGHT kg
			F	G	J	V	øZ	
2	MGR5/QA	F05	255	226	56	42	102	27
3	MGR7/QA	F07	268	217	61	52	200	56
4	MGR10/QA	F10	303	252	61	52	305	80
6	MGR14/QA	F16	381	306	92	86	813	196
8	MGR14/QA	F16	381	306	92	86	813	354
10	MGR15/QA	F16	437	346	103	104	813	482
12	MGR16/QA	F25	422	348	119	53	813	714
14	MGR20/K85A	F25	539	430	131	140	610	899
16	MGR30/K105A	F30	620	470	131	182	711	1269
18	MGR30/K105A	F30	620	470	131	182	711	1709
20	MGR30/K105A	F30	620	470	131	182	711	2319
24	MGR40/K135A	F35	662	490	169	209	711	3564

Imperial units

ASME Class 150

NPS	Gear	Dimensions, inch					øZ	WEIGHT lbs
		ISO Mounting	F	G	J	V		
2	MGR 5/QA	F05	10.04	8.90	2.20	1.65	4.02	51
3	MGR 5/QA	F05	10.04	8.90	2.20	1.65	4.02	86
4	MGR7/QA	F07	10.55	8.54	2.40	2.05	7.87	126
6	MGR10/QA	F10	11.93	9.92	2.40	2.05	12.01	346
8	MGR12/QA	F14	14.53	11.97	3.43	2.80	20.00	587
10	MGR14/QA	F16	15.00	12.05	3.62	3.39	32.01	869
12	MGR14/QA	F16	15.00	12.05	3.62	3.39	32.01	1299
14	MGR16/QA	F25	16.61	13.70	4.69	2.09	32.01	1806
16	MGR16/QA	F25	16.61	13.70	4.69	2.09	32.01	2688
18	MGR20/K85A	F25	21.22	16.93	5.16	5.51	24.02	3217
20	MGR20/K85A	F25	21.22	16.93	5.16	5.51	24.02	4187
24	MGR30/K105A	F30	24.41	18.50	5.16	7.17	27.99	6315

ASME Class 300

NPS	Gear	Dimensions, inch					øZ	WEIGHT lbs
		ISO Mounting	F	G	J	V		
2	MGR5/QA	F05	10.04	8.90	2.20	1.65	4.02	60
3	MGR7/QA	F07	10.55	8.54	2.40	2.05	7.87	123
4	MGR10/QA	F10	11.93	9.92	2.40	2.05	12.01	176
6	MGR14/QA	F16	15.00	12.05	3.62	3.39	32.01	432
8	MGR14/QA	F16	15.00	12.05	3.62	3.39	32.01	781
10	MGR15/QA	F16	17.20	13.62	4.06	4.09	32.01	1063
12	MGR16/QA	F25	16.61	13.70	4.69	2.09	32.01	1574
14	MGR20/K85A	F25	21.22	16.93	5.16	5.51	24.02	1982
16	MGR30/K105A	F30	24.41	18.50	5.16	7.17	27.99	2798
18	MGR30/K105A	F30	24.41	18.50	5.16	7.17	27.99	3768
20	MGR30/K105A	F30	24.41	18.50	5.16	7.17	27.99	5113
24	MGR40/K135A	F35	26.06	19.29	6.65	8.23	27.99	7859

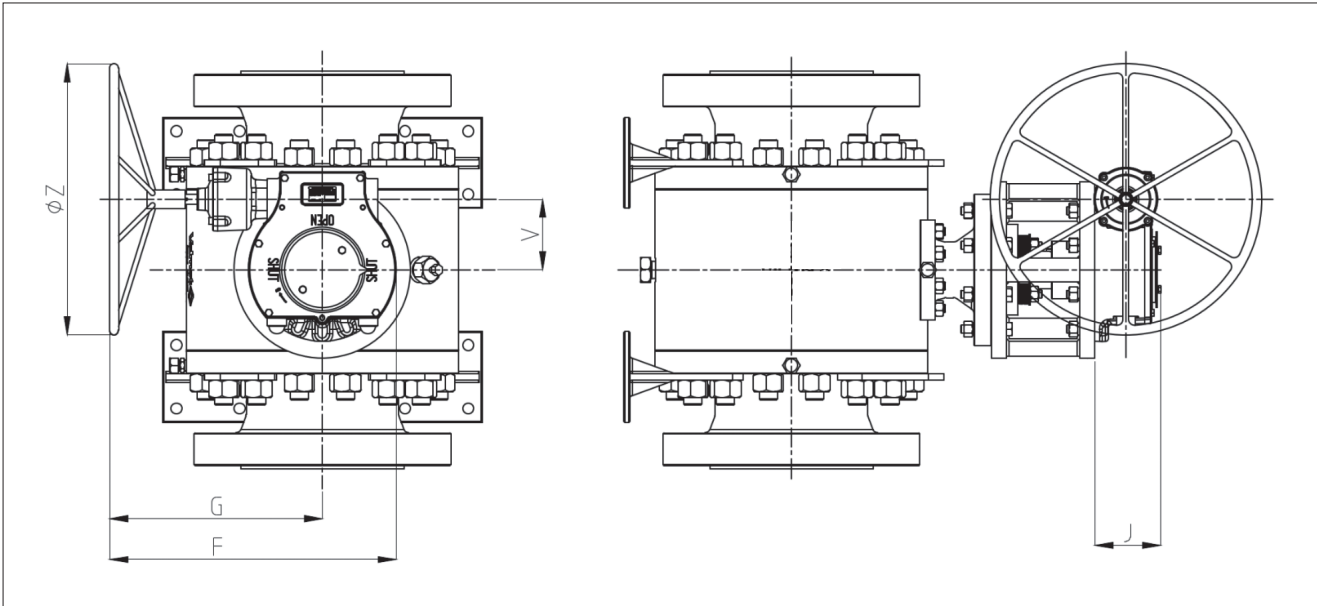

SI units

ASME Class 600

NPS	Gear	ISO Mounting	Dimensions, mm					WEIGHT kg
			ØZ	G	F	V	J	
2	MGR7/QA	F10	200	217	268	52	61	48
3	MGR10/QA	F12	300	252	303	52	61	92
4	MGR12/QA	F14	500	304	369	71	87	185
6	MGR14/QA	F16	700	306	381	86	92	354
8	MGR16/QA	F25	800	348	422	53	119	645
10	MGR20/K85A	F25	600	430	539	140	131	950
12	MGR20/K85A	F25	600	430	539	140	131	1240
14	MGR30/K105A	F30	700	470	620	182	172	1715
16	MGR30/K105A	F30	700	470	620	182	172	2225
18	MGR40/K135A	F35	700	490	662	209	215	3040
20	MGR40/K135A	F35	700	490	662	209	215	3770

Imperial units

ASME Class 600

NPS	Gear	ISO Mounting	Dimensions, inch					WEIGHT lbs
			ØZ	G	F	V	J	
2	MGR7/QA	F10	7.9	8.54	10.55	2.05	2.40	106
3	MGR10/QA	F12	11.8	9.92	11.93	2.05	2.40	203
4	MGR12/QA	F14	19.7	11.97	14.53	2.80	3.43	408
6	MGR14/QA	F16	27.6	12.05	14.98	3.39	3.62	781
8	MGR16/QA	F25	31.5	13.70	16.63	2.09	4.69	1423
10	MGR20/K85A	F25	23.6	16.93	21.21	5.51	5.16	2095
12	MGR20/K85A	F25	23.6	16.93	21.21	5.51	5.16	2735
14	MGR30/K105A	F30	27.6	18.52	24.41	7.17	6.77	3782
16	MGR30/K105A	F30	27.6	18.52	24.41	7.17	6.77	4907
18	MGR40/K135A	F35	27.6	19.31	26.10	8.23	8.46	6704
20	MGR40/K135A	F35	27.6	19.31	26.10	8.23	8.46	8313

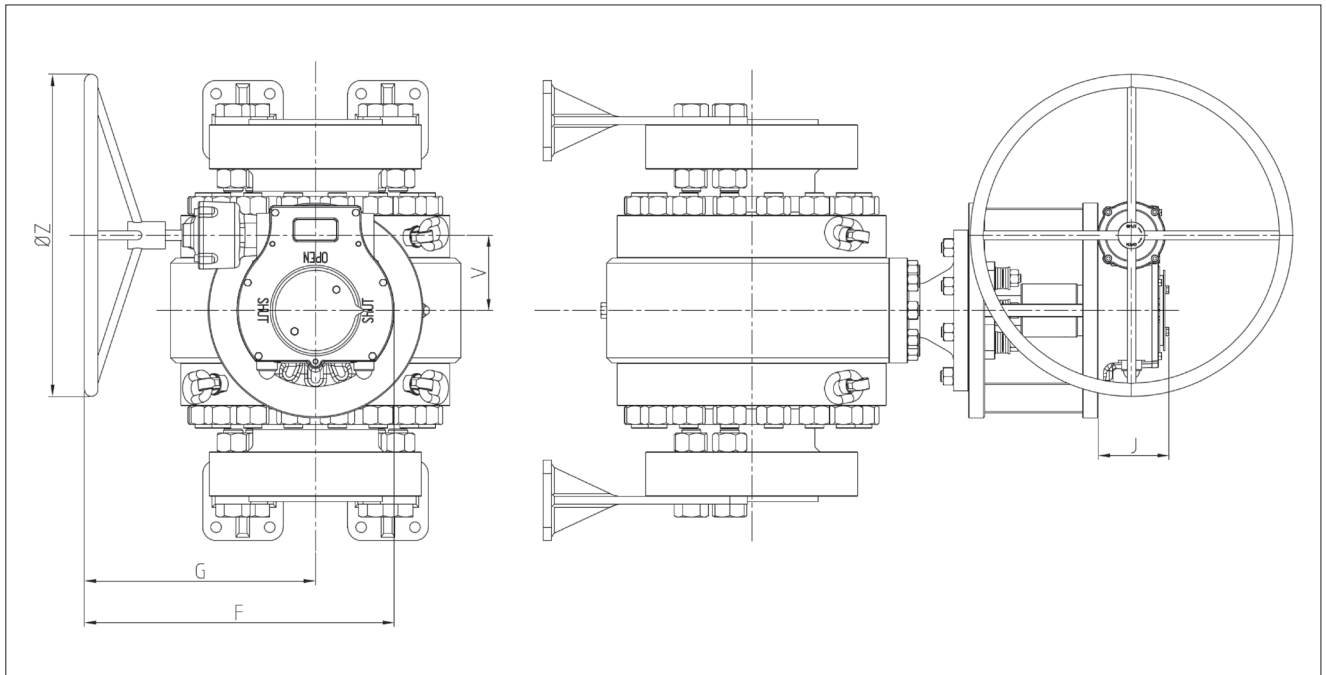

SI units

ASME Class 900

NPS	Gear	ISO Mounting	Dimensions, mm					Weight kg
			ØZ	G	F	V	J	
2	MGR12/QA	F14	500	304	369	71	87	117
3	MGR12/QA	F14	500	304	369	71	87	210
4	MGR14/QA	F16	700	306	381	86	92	330
6	MGR15/QA	F16	800	346	437	104	103	790
8	MGR20/K85A	F25	600	430	539	140	131	1340
10	MGR30/K105A	F30	700	470	850	182	172	2510
12	MGR30/K105A	F30	700	470	850	182	172	3475

ASME Class 1500

NPS	Gear	ISO Mounting	Dimensions, mm					Weight kg
			ØZ	G	F	V	J	
2	MGR12/QA	F14	500	304	369	71	87	117
3	MGR12/QA	F14	500	304	369	71	87	260
4	MGR15/QA	F16	800	346	437	104	103	380
6	MGR16/QA	F25	800	348	422	53	119	925
8	MGR20/K85A	F25	600	430	539	140	131	1650
10	MGR30/K105A	F30	700	470	850	182	172	2816
12	MGR40/K135A	F35	700	490	662	209	215	4040

Imperial units

ASME Class 900

NPS	Gear	ISO Mounting	Dimensions, inch					Weight lbs
			ØZ	G	F	V	J	
2	MGR12/QA	F14	19.70	11.97	14.53	2.80	3.43	258
3	MGR12/QA	F14	19.70	11.97	14.53	2.80	3.43	463
4	MGR14/QA	F16	27.60	12.05	14.98	3.39	3.62	728
6	MGR15/QA	F16	31.50	13.62	17.20	4.11	4.04	1742
8	MGR20/K85A	F25	23.60	16.93	21.21	5.51	5.16	2954
10	MGR30/K105A	F30	27.60	18.52	24.41	7.17	6.77	5534
12	MGR30/K105A	F30	27.60	18.52	24.41	7.17	6.77	7661

ASME Class 1500

NPS	Gear	ISO Mounting	Dimensions, inch					Weight lbs
			ØZ	G	F	V	J	
2	MGR12/QA	F14	19.70	11.97	14.53	2.80	3.43	258
3	MGR12/QA	F14	19.70	11.97	14.53	2.80	3.43	573
4	MGR15/QA	F16	31.50	13.62	17.2	4.11	4.04	835
6	MGR16/QA	F25	31.50	13.70	16.63	2.09	4.69	2040
8	MGR20/K85A	F25	23.60	16.93	21.21	5.51	5.16	3638
10	MGR30/K105A	F30	27.60	18.52	24.41	7.17	6.77	6208
12	MGR40/K135A	F35	27.60	19.31	26.10	8.23	8.46	8907

12. EU DECLARATION OF CONFORMITY FOR ATEX APPROVED VALVES



EU DECLARATION OF CONFORMITY for ATEX approved valves



Manufacturer:
Valmet Flow Control Private Limited
E-61, Additional MIDC Area, Anand Nagar,
421506 Ambernath (East)
Maharashtra, India

EU Authorised Representative: Valmet Flow Control Oy, Vanha Porvoontie 229, 01380
Vantaa, Finland. Contact details: [+358 10 417 5000](tel:+358104175000)

This declaration of conformity is issued under the sole responsibility of the manufacturer.

Product:	Neles Ball valves	
Type:	6D-series	
ATEX group and category:	Ex II 2 GD, II 3 GD	
Ex GAS:	Ex h IIC 85°C...Tmax Gb/Gc	
Ex DUST:	Ex h IIIC T85°C...T(Tmax) Db/Dc	
	Tmax= valve max. temperature in name plate	

Manufacturer's certificates:

Standard / Directive	Notified Body and NoBo number	Certificate No.
ISO 9001:2015	LRQA (Certification body)	00029133 (Approval No.)
PED 2014/68/EU Module H	DNV DNV Business Assurance Italy S.r.l. 0496	142306-2013-CE-FIN-ACCREDIA
ATEX 2014/34/EU Annex IV	DNV Product Assurance AS Norway 2460	Presafe 18 ATEX 91983Q Issue 6

ATEX 2014/34/EU Annex VIII technical files are archived by Notified Body number 0537

The object of the declaration described above is in conformity with the relevant Union harmonisation legislation:

PED 2014/68/EU	Valve
ATEX 2014/34/EU	Non-electrical equipment

Main components:

Valve: The valve is suitable for service up to PED Cat III Valve design standard: ASME B16.34

Installation, Maintenance and Operating instructions manual (IMO) must be followed before installation in order to ensure proper and safe mounting and usage of equipment.

The product above is manufactured in compliance with the applicable European directives and technical specifications/standards EN10204. The product is in conformity with the customer order.

Instrumentation and accessories having equal protection concept, level and performance specification with the original can be presumed to be in conformity with this Declaration of Conformity.

Protection from e.g. static electricity caused by the process or connected equipment must be considered by the user (EN 60079-14 § 6). EN 60079-19 applies for modifications.

Non-electrical equipment is according EN 80079-37:2016 and EN 80079-36:2016. The actual surface temperature of non-electrical equipment is depended on the process and ambient conditions (EN 80079-36:2016 § 6.2.5 and 6.2.7). The protection from high or low temperature must be considered by the end user before put into service.

The product does not possess any residual risk according to hazard analysis conducted under the applicable directives providing that the procedures stated by the IMO are followed and the product is used under conditions mentioned in the technical specifications.

Documents with digital and/or e-signature conveyed by Valmet Flow Control conform to the Regulation (EU) No 910/2014 as well as the national code on e-signatures. In order to secure the integrity of the document, the authenticity of the sender, and indisputableness of the dispatch the identification is covered by individual ID codes, passwords, and by regularly changing passwords. The authorization to sign documents is based on organizational position and/or is task related. The impartial third party in the company bestows the access right with predefined authorities to particular databases.

Ambernath 1.10.2025

Matti Rousku, Quality Director

13. HOW TO ORDER

1.	2.	3.	4.	5.	6.	7.	8.	9.	10.	11.	12.	13.	14.	15.	16.
6D	F	06	C	W	B1	G1	J2	AA	M4	AA	R	V1	A	A	-

1.	Valve series description
6D	Full bore, flanged, trunnions, long pattern

2.	Port type
F	Full bore (circular opening)

3.	Valve size	Class
02	NPS 2 or DN 50	150, 300, 600, 900, 1500
03	NPS 3 or DN 80	
04	NPS 4 or DN 100	
06	NPS 6 or DN 150	
08	NPS 8 or DN 200	
10	NPS 10 or DN 250	
12	NPS 12 or DN 300	150, 300, 600
14	NPS 14 or DN 350	
16	NPS 16 or DN 400	
18	NPS 18 or DN 450	
20	NPS 20 or DN 500	
24	NPS 24 or DN 600	

4.	Pressure class
C	ASME Class 150
D	ASME Class 300
F	ASME Class 600
G	ASME Class 900
H	ASME Class 1500

5.	End connection style
W	Raised face, ASME B16.5 (Ra 3.2-6.3)
Z	Ring joint, ASME B16.5 (for Class 900, 1500)

6.	Construction and application			
	Seat type	Emergency sealant injection		Cavity drain & vent
		Seat	Stem	
B1 a)	DBB*		Included	Included
B2 b)	DBB*	Included	Included	Included
B4 std)	DBB*			Included
B5	DBB*	Included		Included

*Double block and bleed effect seat configuration
a) For valves sizes NPS 2 to 6 in Class 150 & 300 and NPS 2 in Class 600 -Select option B1
b) For valve sizes ≥ NPS 8 in Class 150 & 300 and ≥ NPS 3 in Class 600 -Select option B2
std) Standard option for all Class 900 & 1500 rated valves. Also available in Class 150, 300, 600

7.	Stem seal / Gland packing			
	Stem seal	Temperature range	Gland packing	Class
G1	O-ring	-29°C to +200°C	Graphite	150, 300
G2	O-ring	-29°C to +200°C	Graphite+Live loading	600
G5		-46°C to +400°C	Graphite+Live loading	900, 1500

8.	**Body material	Class
J2	ASTM A216 Gr. WCB (Carbon steel)	150 & 300
S6	ASTM A351 Gr. CF8M (Stainless steel)	150 & 300
AA	ASTM A105 (Carbon steel)	600, 900, 1500
SP	ASTM A182 Gr. F316 (Stainless steel)	600, 900, 1500

** Forging body options not offered in Class 150 & 300, and Casting body options not offered in Class 600, 900, 1500

9.	Ball material
AA	c) ASTM A105 + ENP
M4	410 SS (13% Cr)
SP	316 SS

c) Used only in Carbon steel body valves

10.	Stem material
M4	c) 410 SS (13% Cr)
PH	17-4PH SS

c) Used only in Carbon steel body valves in Class 150 & 300

11.	Seat material
AA	c) ASTM A105 + ENP
M4	410 SS (13% Cr)
SP	316 SS

c) Used only in Carbon steel body valves

12.	Seat insert material	Temperature
R	Reinforced PTFE (RPTFE) for Class 150 & 300	-50°C to +220°C
D	Devlon® for Class 600	-50°C to +176°C
P	PEEK for Class 900 & 1500	-46°C to +230°C

13.	O-ring material	Temperature
V1	d) FKM (Fluoroelastomer) in Class 150 & 300 & FKM AED in Class 600	-29°C to +200°C
L1	Spring energized fluoropolymer lip seal in Class 900 & 1500	-46°C to +230°C

d) Selection covers all O-rings used inside the valve

14.	#Bolting material
A	B7/2H
D	e) B8M/8M
F	f) L7M/7M

Body & gland bolting material are same
e) Used on Stainless steel body valves
f) NACE bolting for Carbon steel body valves

15.	Model code
A	For all valves

16.	Option / Modifier code
	Blank, Standard option with Pressure equipment directive 2014/68/ EU (PED)
A	Valve with API 6D monogram
I	IOGP S-562 design compliance

Note: Other sizes, class, end connections, materials, construction, seals, etc. are available on request. Please contact nearest Valmet sales office for support. Valve working temperature range depends on the temperature limit of all soft parts used. Check limitations on Sign. 7, 12, and 13. For chemical resistance chart of metallic valve parts refer Valmet publication T101-1EN, and for non-metallic valve parts refer T101-3EN.

14. GENERAL SAFETY WARNINGS AND DISCLAIMERS

General safety warnings

Lifting

1. Always use a lifting plan created by a qualified person to lift this equipment. Lifting guidance is provided in this IMO (Installation, Maintenance and Operation manual) to assist in lifting plan development. Think about the center of gravity (CG) of the equipment being lifted. Make sure the CG is always under the central lifting point.
2. Valves may be equipped with lifting threads on the body or on the flanges. These are intended to be used with the lifting plan.
3. Use only correct and approved lifting devices. Ensure that lifting devices and straps are securely attached to the equipment prior to lifting.
4. Check, that lifting devices are not damaged and in good condition with a valid check stamp prior to use.
5. Workers must be trained for lifting and handling valves.
6. Never lift an assembly by the instrumentation (solenoid, positioner, limit switch, etc.) or by the instrumentation piping. Straps and lifting devices should be fitted to prevent damage to instrumentation and instrumentation piping. Failure to follow the lifting guidance provided may result in damage and personal injury from falling objects.

Work activities on the valve

1. Wear your personal safety equipment. Personal safety equipment includes but is not limited to protective shoes, protective clothing, safety glasses, helmet, hearing protection and working gloves.
2. Always follow the local safety instructions in addition to the Valmet instructions. If Valmet instructions conflict with local safety instructions, stop work and contact Valmet for more information.
3. Before beginning service on the equipment, make sure that the actuator is disconnected from any kind of power source (pneumatic, hydraulic, and/or electric), and no stored energy is applied on the actuator (compressed spring, compressed air volumes, etc.). Do not attempt to remove a spring return actuator unless the stop screw is carrying the spring force.
4. Make sure that there is a LOTOTO (Lock Out / Tag Out / Try Out) procedure in place for the system in which the valve is installed and strictly follow it.
5. Always make sure that the pipeline is depressurized and in ambient temperature condition before maintenance work is started.
6. Keep hands and other body parts out of the flow port when the valve is being serviced and the actuator is connected to the valve. There is a high risk of serious injury to hands and/or fingers due to malfunction if the valve suddenly starts to operate.
7. Beware of Trim (Disc, Ball or Plug) movement even when the valve is disassembled. Trim may move simply due to the weight of the part or change in position of the valve. Keep hands or other body parts away from locations where they may be injured by movement of the trim. Do not leave objects near or in the valve port which may fall in and need to be retrieved.

General disclaimers

Receiving, handling and unpacking.

1. Respect the safety warnings above!
2. Valves are critical components for pipelines to control high pressure fluids and must therefore be handled with care.

3. Store valves and equipment in a dry and protected area until the equipment is installed.
4. Do not exceed the maximum storage temperatures given in the IMO (installation, maintenance, and operating instructions).
5. Keep the original packaging on the valve as long as possible to avoid environmental contamination by dust, water, dirt, etc.
6. Remove the valve endcaps just before mounting into the pipeline.
7. FOR YOUR SAFETY IT IS IMPORTANT TO FOLLOW THESE PRECAUTIONS BEFORE REMOVAL OF THE VALVE FROM THE PIPELINE OR ANY DISASSEMBLY:
 - Be sure you know what flow medium is in the pipeline. If there is any doubt, confirm with the proper supervisor.
 - Wear any personal protective equipment (PPE) required for working with the flow medium involved in addition to any other PPE normally required.
 - Depressurize the pipeline, bring to ambient temperature, and drain the pipeline flow medium.
 - Cycle the valve to relieve any residual pressure in the body cavity.
 - After removal but before disassembly, cycle the valve again until no evidence of trapped pressure remains.
 - The valves with offset shaft (Butterfly, eccentric rotary plug) have greater trim area on one side of the shaft. This will cause the valve to open when pressurized from the preferred direction without a locking handle or an actuator installed.
 - **WARNING: DO NOT PRESSURIZE THE ECCENTRIC VALVE WITHOUT A HANDLE OR AN ACTUATOR MOUNTED ON IT!**
 - **WARNING: DO NOT REMOVE A HANDLE OR AN ACTUATOR FROM AN ECCENTRIC VALVE WHILE PRESSURIZED!**
 - Before installing the eccentric valve in or remove it from the pipeline, cycle the valve closed. Eccentric valves must be in the closed position to bring the trim within the face to face of the valve. Failure to follow these instructions will cause damage to the valve and may result in personal injury.

Operating

8. The identification plate (ID-plate, type plate, nameplate, or engraved markings) on the valve gives the information of max. process conditions to the valve.
9. (For soft seats) The practical and safe use of this product is determined by both the temperature and pressure ratings of the seat and body. Read the identification plate and check both ratings. This product is available with a variety of seat materials. Some seat materials have pressure ratings that are lower than the body ratings. All body and seat ratings are dependent on the valve type, size and material of the body and seat. Never exceed the marked rating.
10. Temperatures and pressures must never exceed values marked on the valve. Exceeding these values may cause uncontrolled release of pressure and process medium. Damage or personal injury may result.
11. The operating torque of the valve may rise over time due to wear, particles or other damage of the seat. Never exceed the actuator torque preset values (air supply, position). Application of excessive torque may cause damage to the valve.
12. Valmet valves typically are designed to be used in atmospheric conditions. Do not use valves under external pressurized conditions unless specifically designed and explicitly marked for this service.

13. Avoid Pressure shocks or water hammer. Systems with high pressure valves should be equipped with a bypass to reduce the differential pressure before opening the valve to avoid pressure shock.
14. Avoid thermal shock. High temperature, Low temperature and cryogenic valves should be operated in a way that limits the rate of increase or decrease in temperature. The valve should be thermally stabilized before being pressurized.
15. Materials of the valve are carefully selected for the process conditions. Changes to the process media can have a major impact on function and safety of the valve. Always confirm the materials are suitable for the service prior to installation.
16. As the use of the valve is application specific, several factors should be considered when selecting a valve for a given application. Therefore, some situations in which the valves are used are outside the scope of this manual.
17. It is the end user's responsibility to confirm compatibility of the valve materials with the intended service, however if you have questions concerning the use, application, or compatibility of the valve for the intended service, contact Valmet for more information.
18. Never use a valve with enriched or pure oxygen if the valve is not explicitly designed and cleaned for oxygen. Selected materials and design have a major impact on the safety to operate the valve with oxygen.
19. Valves intended for use in or with explosive atmospheres must be equipped with a grounding device and marked according ATEX (or equivalent international standards).
20. Manual handles are available for specific butterfly valve sizes and maximum line pressures. Do not operate a valve with a handle or wrench outside the size and pressure limits stated in the IMO. High line pressure may create a large enough force to pull the handle from the operator's hands. Damage or personal injury may result.
29. Do not use sharp tools, grinding machines, or files to work on functional surfaces such as sealing, seating or bearing surfaces as this can damage these surfaces.
30. Check the condition of sealing surfaces on the seats, trim (disc, ball, plug, etc.), body and body cap. Replace parts if there are significant wear, scratches, or damage.
31. Check the wear of bearings and bearing contact surfaces on the shaft and replace damaged parts if necessary.
32. Do not weld on pressure retaining parts without an ASME and PED qualified procedure and personnel.
33. Pressure retaining parts of valves in high temperature applications must be carefully examined for the effects of material creep and fatigue.
34. Make sure that the valve is positioned in the correct flow direction into the pipeline.
35. If the valves are marked to be suitable for explosive atmospheres, the correct function of the discharging device must be tested before returning to service.
36. Always work in a clean environment. Avoid getting particles inside the valve due to machining, grinding, or welding nearby.
37. Never store a valve in maintenance without flow port protection.
38. When pressure testing valve seats, never exceed the maximum operating pressure of the system or the maximum shut-off pressure marked on the valve identification plate.
39. Actuator mounting and unmounting:
 - Before installing the actuator on to the valve, be sure the actuator is properly indicating the valve position. Failure to assemble these to indicate correct valve position may result in damage or personal injury.
 - When installing or removing a linkage kit, best practice is to remove the entire linkage assembly, including couplings which may fall off the valve during lifting or when position changes.
 - Mounting sets have been designed to support the weight of the Valmet actuator and recommended accessories either as is or with additional actuator support. Use of the linkage to support additional equipment or additional weight such as people, ladders, etc. may result in equipment damage or personal injury.

Maintenance

21. Respect the safety warnings above!
22. Plan service and maintenance actions, that spare parts, lifting devices and service personnel is available.
23. Maintain the valve within the recommended minimum maintenance intervals or within the recommended maximum operating cycles.
24. Always make sure that the valve and the pipeline is depressurized before starting any kind of maintenance work at a valve.
25. Always check the position of the valve before starting maintenance work. Follow the Lock out /tag out (LOTO) rules at the site before starting any maintenance activity.
 - See IMO for the correct stem position.
 - Consider that the positioner may give the wrong signals.
26. Sealing materials (soft sealing parts) should be changed when the valve is in maintenance. Always use original equipment manufacturers (OEM) spare parts to ensure proper performance of the repaired valve.
27. All pressure containing parts must be inspected visually for damage or corrosion. Damaged parts must be replaced.
28. Valve pressure retaining parts and all internals must be inspected for corrosion or erosion which may result in reduced wall thickness on pressure retaining parts. Damaged pressure retaining parts must be replaced with original equipment manufacturer's (OEM) replacement parts or repaired to factory specifications by an authorized Valmet service partner in order to maintain the warranty.
40. The valve should be installed between flanges using appropriate gaskets and fasteners that are compatible with the application, and in compliance with applicable piping codes and standards. Center the gaskets carefully when fitting the valve between the flanges. Do not attempt to correct pipeline misalignment by means of the flange bolting.
41. Repairs on valves for special service like Oxygen, Chlorine, and Peroxide, have special requirements.
 - Parts must be cleaned appropriate to the service and protected from contamination prior to assembly.
 - Assembly areas and tools must be clean and dry to prevent contamination of the parts during assembly.
 - Test equipment must be clean and dry to prevent contamination during testing. This includes the test equipment internals that may allow particles or other contamination into the test medium during the test.
 - Lubrication shall be used only if specifically required in the instructions. Where lubrication is required, the lubricant must be approved for the service by the end user.

Valmet Flow Control Oy

Vanha Porvoontie 229, 01380 Vantaa, Finland.

Tel. +358 10 417 5000.

www.valmet.com/flowcontrol

Subject to change without prior notice.

Neles, Neles Easyflow, Jamesbury, Stonel, Valvcon and Flowrox, and certain other trademarks, are either registered trademarks or trademarks of Valmet Oyj or its subsidiaries in the United States and/or in other countries.

