

AxiomTM AMI

Nonincendive & I.S. on/off valve controller

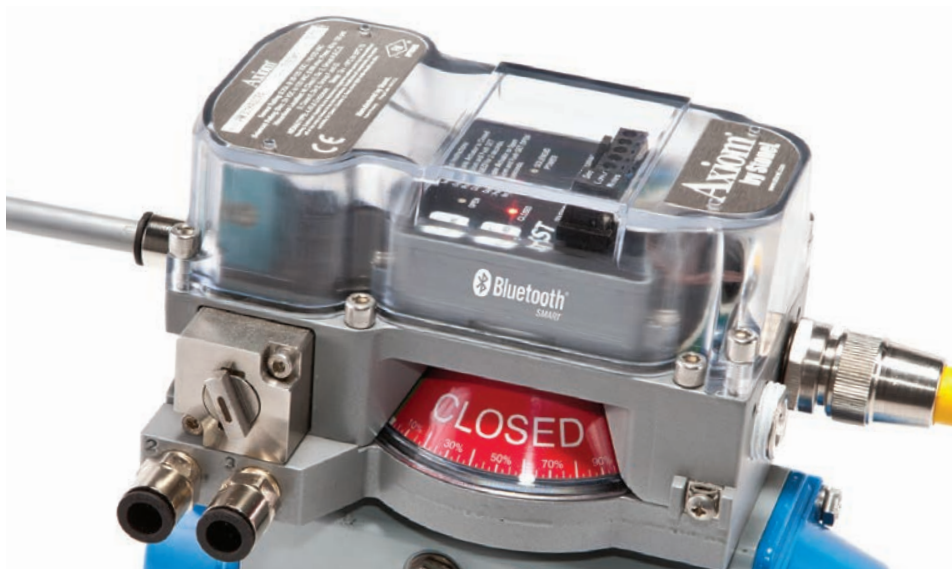



Axiom AMI

Advanced monitoring and control in nonincendive and general purpose applications

The Axiom AMI integrates solid state continuous sensing and pneumatic control to give long life and reliable performance in process applications. The AMI also features the capability for intermediate valve control and diagnostics to offer more cost saving benefits.

Advanced performance

The AMI features StoneL's non-contact continuous position sensing system which eliminates shafts, bushings, and wear parts prone to failure. It also has an o-ring sealed pneumatic valve spool with pilot that is tolerant of contaminants found in most process plant air systems. The result of these design features is consistent reliable performance over the life of the automated valve system.

Wide variety of functions offer exceptional value

Select from standard SST sensors for conventional switching, NAMUR sensors for intrinsically safe applications or a broad array of communication options including AS-Interface, DeviceNet™ and Foundation Fieldbus. The Expeditor version provides the capability to offer additional value for special filling and flow dampening applications with intermediate control. And maintenance costs may be reduced using the diagnostic systems available with AS-Interface or in conventional 4-20 mA applications with the HART protocol.

Corrosion-resistant

The AMI features an anodized epoxy-coated aluminum housing with a Lexan® cover to withstand corrosive process environments. The Lexan® cover may also be optionally fusion coated for organic solvents. Or an aluminum cover may be selected for special highly corrosive applications.



Standard Lexan® polycarbonate cover
(Consult factory for optional aluminum cover)

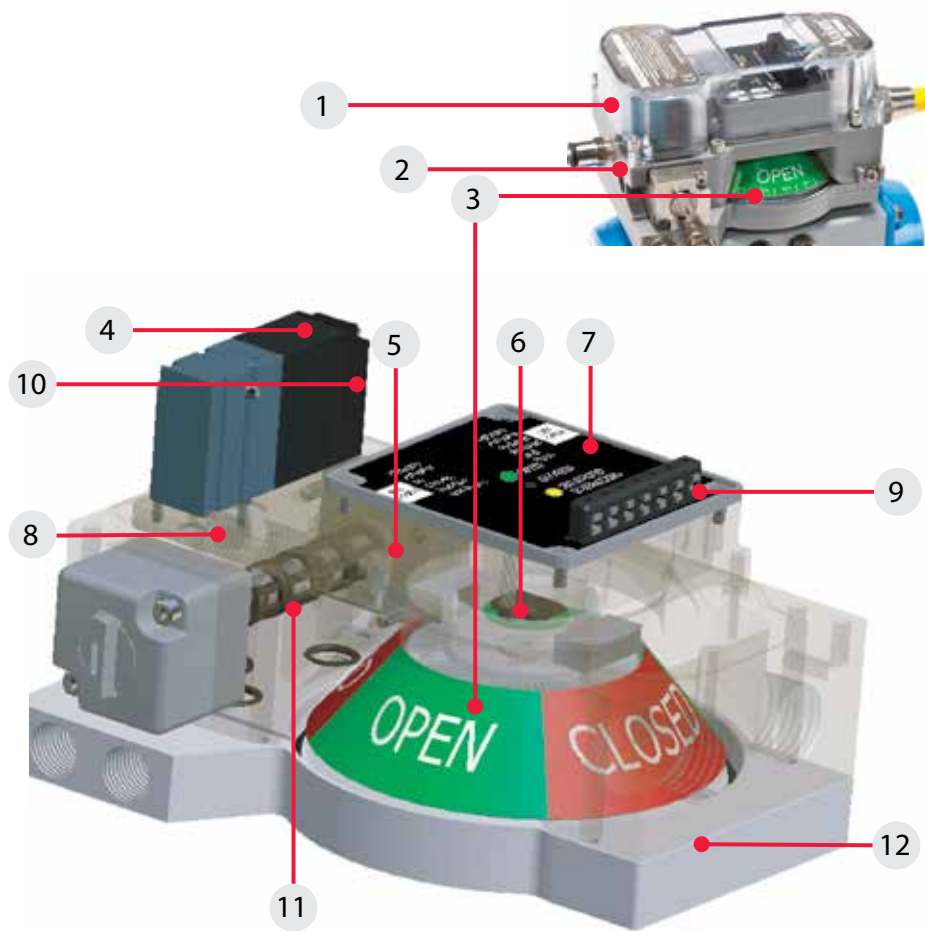

Features

- 1. The Axiom is corrosion proof, temporarily submersible and suitable for use in hazardous areas.** Designed for NEMA 4, 4X & 6; (IP67) Class I & II Div 2 nonincendive (Ex nA, Zone 2) and Class I & II Div 1 & 2 (Ex ia, Zones 0, 1, & 2) Intrinsically Safe.
- 2. High strength durable enclosure and pneumatic manifold** are constructed of anodized aluminum and epoxy coated. Impact-resistant cover is made of high strength Lexan® polycarbonate. All fasteners are stainless steel.
- 3. High visibility mechanical and electronic indication** confirm open and closed position and solenoid status for greater safety and convenience.
- 4. Universal voltage solenoid system** operates on less than 0.6 watts of power and is burn out proof. Standard version will accept 24 VDC, 120 VAC or 240 VAC, reducing stocking requirements.
- 5. Electronic sensing, switching and communication components are sealed** and potted inside function module to protect against residual moisture, vibration and corrosives.
- 6. High accuracy position sensor system is solid state** with no moving wear points for highly reliable and precise position feedback.
- 7. Push button set points** for open and closed accurately lock in position settings. Settings remain in place when power is removed and reapplied.
- 8. Integral pneumatic valve** operates on standard plant air and will cycle most actuators in less than two seconds.
- 9. Wiring and maintenance access is quick** and convenient for easy set-up and installation.
- 10. Internal manual pneumatic valve override** is standard enabling local automated valve operation.
- 11. Standard 5-way, 2-position valve** operates both double and single-acting actuators and features a rebreather to feed instrument air into spring side of actuator to keep out corrosives.
- 12. Axiom directly attaches to VDI/VDE 3845 (NAMUR)** actuators and many others using a compact mounting manifold system (sold separately).

Pneumatic control

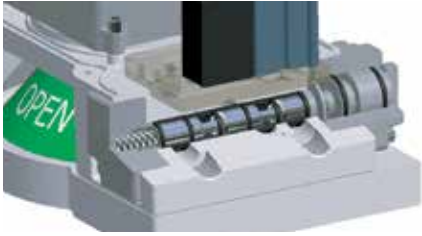

The Axiom's pneumatic valve system consists of a low-power pilot that drives the main high-flow spool valve. Pilots may be selected for conventional or bus networking applications. Both stages of the pneumatic valve system have been designed for long life, high tolerance to air line contaminants, and ease of maintenance should components become fouled.

Special features

- Pilot and main spool design offer long life, exceptional tolerance to dirty air, and tight shut-off.
- Spool and pilot valve may be conveniently removed and cleaned if large contaminants become lodged in the valve.
- Universal voltage solenoid system may be used for standard AC or DC applications.
- Five-way, two-position spring return configuration may be used for either single- or double-acting actuators. Dual coil shuttle piston versions are also available for fail-in-last position.
- Low power consumption of solenoid reduces current flow on bus networks enabling more units and longer distances on a single segment.
- Rebreather channels exhausted air from pressurized side of actuator into spring side, preventing ingestion of contaminated air from the environment that may corrode springs or actuator internals.
- Standard internal manual override enables convenient set-up.

Dual pilot configuration

Dual pilot options may be selected for special applications such as shuttle piston for fail-in-last position. External manual override options are also readily available. For special valve configurations with non-standard manual override features please consult StoneL.



Specifications

Pneumatic valves	
Valve design	Pilot operated spool valve
Pilot operator options	Solenoid coil or piezo
Configuration	Single pilot: 5-way, 2-position spring return Dual pilot: 5-way, 2-position shuttle piston
Flow rating	0.70 Cv
Axiom porting	¼" NPT
Manifold porting	¼" NPT
Operating pressure	40 to 120 psi (2.7 to 7.5 bar)
Filtration requirements	40 micron (Piezo, 30 micron)
Operating temperature	See pilot specifications below
Manual override	Internal momentary standard External momentary available External latching available
Materials of construction	
Aluminum enclosure	Spool: nickel-plated aluminum Body: epoxy-coated anodized aluminum Seal spacers: Polysulfone End-caps and fasteners: stainless steel Spool seals: nitrile compound O-rings: nitrile compound
Piezo pilot (bus powered Foundation Fieldbus)	
Filtration requirements	Dried/30 micron
Operating temperature	-10° to 60° C (14° to 140° F)
Electrical ratings	<i>_A option</i> 2 mA @ 6.5 VDC
Solenoid pilot	
Filtration requirements	40 micron
Electrical ratings	<i>_H option</i> 0.6 watt @ 22 - 250 VAC/VDC <i>_D option</i> 0.5 watt @ 24 VDC <i>_E option</i> 0.5 watt @ 12 VDC (intrinsically safe)
Operating temperature	<i>Standard (S)</i> -18° to 50° C (0° to 122° F) <i>Extended (T)</i> -40° to 80° C (-40° to 176° F)
IS entity parameters	Ui = 28 VDC Ii = 120 mA Ci = 0 Li = 0 Pi = 1.0 watt

Manifold and mounting system

The mounting manifold system directly attaches the Axiom to the actuator and ports air from the pneumatic valve to the actuator. Included in the manifold system are:

1. Actuator shaft adaptor and fastener.
2. Epoxy-coated anodized aluminum actuator adaptor and pneumatic manifold with o-rings and stainless steel fasteners.

The manifold system readily adapts to VDI/VDE 3845 NAMUR sizes 1 and 2. Special variations may be made for sizes 3, 4 and non-standardized quarter-turn actuator mounting patterns.

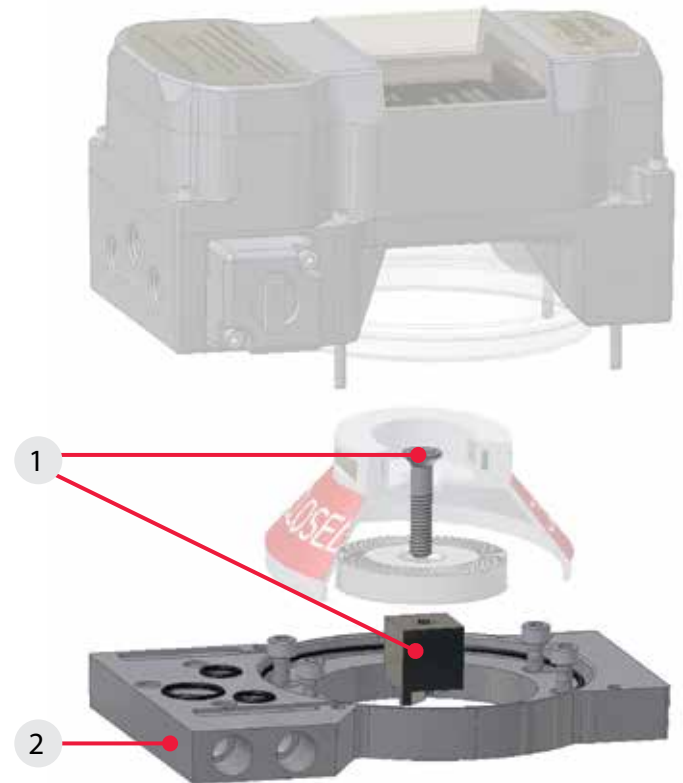

The mounting manifold system is specified and sold separately. Kits are specific to actuator manufacturer. For kit numbers visit: Stonel.com/mounting.

Actuator configuration

The same Axiom model is suitable for both single-acting and double-acting actuators. And the rebreather capability for single-acting is also standard. Field configuration may be made by conveniently removing and reinserting the pneumatic plug for the appropriate actuator type.

Spring return actuator

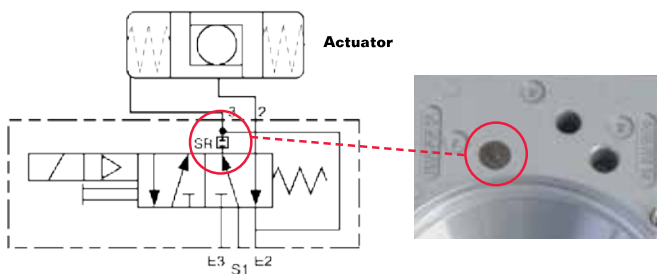

Double-acting actuator

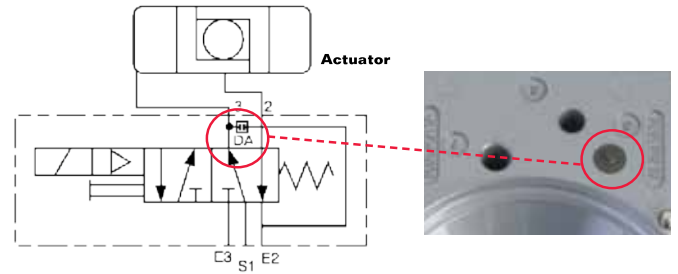

Sensing and communication module

Overview

The Axiom platform has all position sensing, communication or switching integrated into StoneL's C-module. Users may set position switches conveniently and accurately on all modules. And easy to view instructions, along with LED indication, are boldly displayed on the module itself.



Switching and sensor specifications	
SST switching sensors (33)	
Configuration	(2) 2-wire solid state switches (NO) (1) or (2) Solenoid power inputs
Operation	Normally open (solid state)
Maximum current continuous	0.10 amps
Minimum on current	2.0 mA
Maximum leakage current	0.5 mA
Voltage range	20 - 125 VAC/125 VDC
Maximum voltage drop	6.5 volts @ 10 mA; 7.0 volts @ 100 mA
Short circuit	Protected from direct application of up to 125 VAC/VDC
Solenoid input	22 - 130 VAC/VDC
SST switching sensors (35)	
Configuration	(2) 2-wire solid state switches (NO) (1) or (2) Solenoid power inputs
Operation	Normally open (solid state)
Maximum current continuous	0.10 amps
Minimum on current	2.0 mA
Maximum leakage current	0.5 mA
Voltage range	20 - 250 VAC; 8 - 250 VDC
Maximum voltage drop	6.5 volts @ 10 mA; 7.5 volts @ 100 mA
Short circuit	Protected from direct application of up to 125 VAC/VDC only
Solenoid input	20 - 250 VAC; 20 - 60 VDC
NAMUR sensors (44)	
Configuration	(2) NAMUR sensors (EN 60947-5-6; I.S.) (1) or (2) Solenoid power inputs
Operation	Normally closed NAMUR sensors (solid state)
Current ratings	Target on I < 1.0 mA Target off I > 2.1 mA
Voltage range	7 - 24 VDC

Wiring diagram

(33)

SST

Single solenoid

(35)

SST 240V

Dual solenoid

Specify solenoid option _H

Wiring diagram

(44)

NAMUR

Single solenoid

Dual solenoid option also available but not shown.
Specify solenoid option _E

Sensing and communication module

Valve Communication Terminal (VCT) specifications

AS-Interface (96)

Configuration	(2) Discrete sensor inputs (2) Auxiliary discrete inputs (2) Power outputs (solenoids)
Maximum current	160 mA, both outputs combined
Auxiliary inputs	24 VDC @ 2 mA (self-powered)
Outputs	4 watts @ 24 VDC both outputs combined
Outputs, voltage	21 - 26 VDC
Configuration code	ID=F; IO=4 (4DI/2DO)
AS-i version	3.0
Devices per network	31

Wiring diagram (96)

Specify solenoid option _D

AS-Interface VCT with extended addressing (97)

Configuration	(2) Discrete sensor inputs (2) Auxiliary discrete inputs (2) Power outputs (solenoids)
Maximum current	100 mA
Auxiliary inputs	24 VDC @ 2 mA (self-powered)
Output	2 watts @ 24 VDC
Output, voltage	21 - 26 VDC
Configuration code	ID=A; IO=7 (4DI/2DO)
AS-i version	3.0
Devices per network	62

Wiring diagram (97)

Specify solenoid option _D

Valve Communication Terminal (VCT) with diagnostics

AS-Interface (96) with diagnostics (D)

Configuration	(2) Discrete position sensor inputs (1) Low air supply pressure input (1) Stuck valve/actuator input (2) Remote sensor settings (1) Power output (solenoid) (1) Wink feature (1) Parameter bit spring to open/close (1) Peripheral fault bit (bad coil or stuck spool)
Maximum current	< 50 mA
Output	0.5 watt @ 24 VDC
Outputs, voltage	24 VDC
Configuration code	ID=F; IO=7 (4DI/4DO)
AS-i version	3.0
Devices per network	31

Wiring diagram (96) with diagnostics (D)

Specify solenoid option 1D

AS-Interface with Wireless Link (AMI96___W__ models and AMI97)

Configuration	(2) Discrete sensor inputs (2) Auxiliary discrete inputs (2) Power outputs (solenoids)
Maximum current	170 mA
Auxiliary inputs	24 VDC @ 2 mA (self-powered)
Output	4 watts @ 24 VDC
Output, voltage	24 VDC (± 10%)
Configuration code	AMI96 ID=F; IO=4 (4DI/2DO) AMI97 ID=A; IO=7 (4DI/2DO)
AS-i version	3.0
Devices per network	AMI96 31 AMI97 62

Wiring diagram (96) and (97) with Wireless Link (W)

Specify solenoid option _D

Sensing and communication module continued

Valve Communication Terminal (VCT) specifications

Foundation Fieldbus VCT, bus powered (93)

Configuration	(2) Discrete sensor inputs (2) Power outputs (solenoids) Multiple DI/DO blocks or modified output block
Outputs	2 mA @ 6.5 VDC each; current limited to 2 mA (bus powered)
Devices per network	Max of 16 devices recommended

Wiring diagram (93)

Specify solenoid option _A

Valve Communication Terminal (VCT) with diagnostics

HART (71) with diagnostics

Local indication LEDs	Valve open, valve closed, solenoid power
Special configuration attributes	Remote sensor settings Wink
Local diagnostic LEDs	High/low air pressure Stuck valve/actuator Bad coil Stuck spool/pilot
Position feedback	
Current output	4-20 mA
Voltage	14 - 35 VDC (24 VDC nominal)
Loop resistance	250 ohms (min) to 400 ohms (max) at 24 VDC
Pressure accuracy	+/- 1% of full scale
Solenoid power	
Conventional model 1D	0.5 watt (0.02 amp @ 24 VDC)
Intrinsic safety model 1E	0.5 watt (0.04 amp @ 12 VDC)
HART version	7.0

Wiring diagram (71) with diagnostics (D)

Specify solenoid option 1D or 1E

Valve Communication Terminal (VCT) specifications

DeviceNet™ (92)

Configuration	(2) Discrete sensor inputs (2) Remote sensor settings (2) Power outputs (solenoids) (1) Wink feature (1) 4-20 mA auxiliary analog input, 10-bit resolution; no additional power source required
Transmission rate	Software selectable 125K, 250K or 500K baud
Messaging	Polling, cyclic and change of state
Outputs	4 watts @ 24 VDC both outputs combined
Outputs, voltage	24 VDC
Other features	Predetermined output fail state

Wiring diagram (92)

Specify solenoid option _D

Expeditor specifications

Expeditor (80)

Position feedback control (AI)	4-20 mA loop, 9 - 35 VDC
Intermediate position control (AO)	4-20 mA loop, 9 - 35 VDC
Position monitoring accuracy	+/- 1° of rotation
Intermediate control accuracy	+/- 3° of rotation
Solenoid voltage	24 VDC (conventional models) 12 VDC (Intrinsic safety models)

Wiring diagram (80)

Specify pneumatic valve option 2D or 2E

Position sensor and module

Position sensor

The Axiom utilizes a magnetic resistive (Mag Res) sensor system that monitors exact valve position. The Mag Res sensor system is tolerant of lateral and vertical shaft movement which may be experienced in

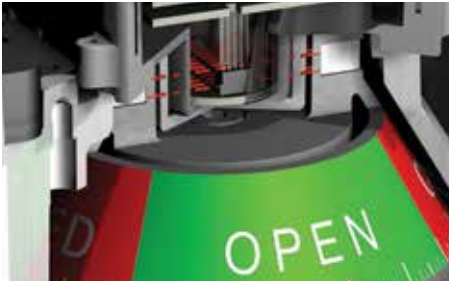

high cycle worn actuators without affecting rotational measurement. No cams, shafts or other mechanical apparatus are required that are prone to wear and binding.

C-module

Used in the Axiom platform, the C-module (continuous sensing) integrates a magnetic resistive sensor system to monitor exact valve position throughout the rotational range. Push button or remote open and closed position setting along with microprocessor based operation make this state-of-the-art system convenient, reliable, and smart.

Open and closed settings

Switches correspond to a particular valve position and are set using the push button panel on the module's sealed membrane pad. Simply operate the actuator to the open position (using standard internal manual override) and push the "Set Open" button. Operate the actuator to the closed position and push the "Set Closed" button. Position settings remain locked in when power is removed and reapplied.

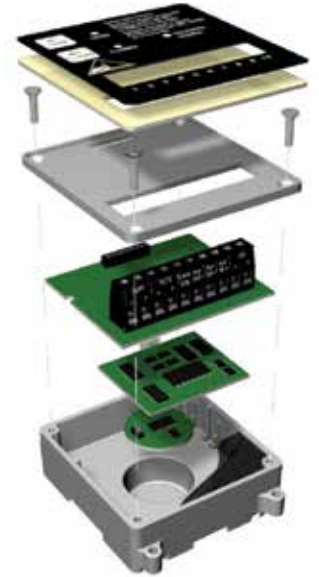

Visual indicator

Visual indicator designations

Clearly view valve position status from up to 75 feet with the Axiom's visual indicator. The indicator's rugged Lexan® construction makes it resistant to physical damage and tolerant to most corrosives.

DESIGNATION	0°	90°
R	RED CLOSED	GREEN OPEN
G	GREEN CLOSED	RED OPEN
1		
2		
X	Specialty configuration - please consult factory	



Diagnostic systems

Reduce plant downtime and cut maintenance costs

The Axiom AS-Interface and HART models feature on-board diagnostics that predict potential automated valve malfunctions. As a result, plant downtime may be reduced by repairing automated valves during planned shutdowns instead of process operations. Should problems occur during process operation, maintenance personnel will be aided by rapidly locating failure causes, consequently speeding up valve repair and operation renewal.



Identify potential problems

- Check air supply pressure**
 Alerts are activated if low or high levels exceed preset thresholds that would threaten pneumatic valve or actuator performance.
- Determine solenoid condition**
 Voltage and current levels are monitored to determine the health of the solenoid coil whenever energized.
- Local trouble-shooting display**
 Device LED array identifies problem sources for rapid trouble-shooting and maintenance at the valve/actuator site.
- Monitor pneumatic spool and pilot valve operation**
 Pneumatic valve spool position is monitored to determine proper shifting performance when the solenoid is energized and de-energized.
- Remote switch setting**
 Open and closed limit switch settings may be made with on-board push buttons or remotely through the control system.
- Field identify with winking**
 To positively confirm the field device identity, the control room may initiate the Wink function that flashes both open and closed LEDs without affecting valve operation.
- Stuck process valve/actuator**
 If the Axiom stalls in mid stroke and no Axiom problem sources are identified an alert will be energized to indicate the problem source is in the valve/actuator assembly.



Axiom with AS-Interface diagnostics in AX & AMI (96)

The AX and AMI (96) offers basic diagnostics for AS-Interface network applications that enable end use customers to increase uptime and reduce maintenance costs. Axiom AS-Interface diagnostic systems interface with any version 2.1 or greater masters/gateways.

Electrical connections

The Axiom with AS-Interface diagnostics uses standard (1-31) addressing with a 4DI/4DO profile to maximize the diagnostic data available via the network. Diagnostic units may be integrated on the same network as other AS-Interface devices.

Control system interface

Interface up to 31 Axiom units into your control system. Communication bits may be mapped into standard DCS or PLC as desired. No special software is required. See the StoneL FieldLink program for information about the cost saving benefits and easy installation of the AS-Interface protocol.

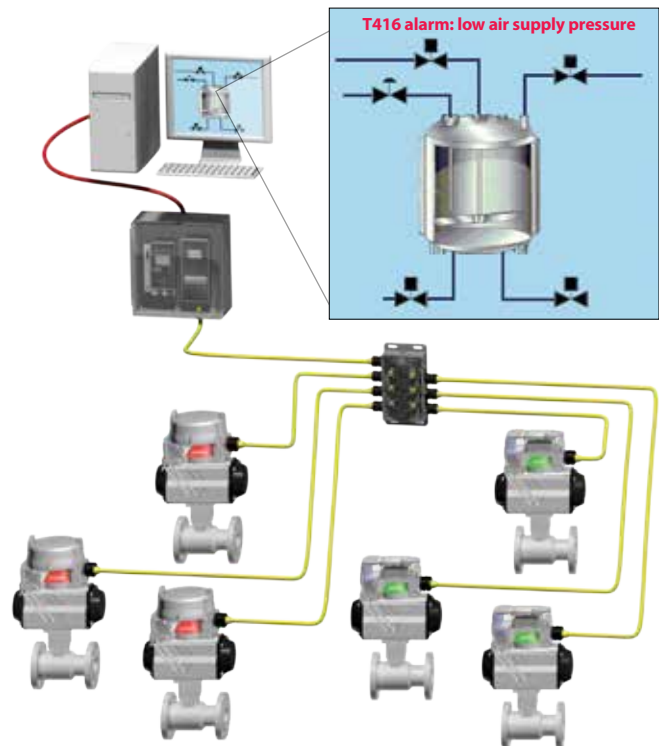



Axiom with HART in AX & AMI (71) features comprehensive predictive diagnostics

The AX71 and the AMI71 is a valve monitoring and control device for discrete quarter-turn automated valves. Used in conventional applications, it has the added capability of providing diagnostic information for the pilot solenoid, spool valve, and actuator. And, the device stores historical data on each open and closed operation.

Excessive valve torque changes

Open and closed breakaway actuator differential pressures are measured and compared to baseline levels during each operation. This enables operators to observe unusual pressure/torque level trends, which may ultimately lead to a malfunction.

Erratic valve/actuator performance

Total travel time and dead time (time between energizing and initial actuator movement) are measured during each operation, recorded, and compared to the baseline. This gives maintenance staff additional clues on potential automated valve problems.

Valve/actuator end-stop changes

Exact valve position is continuously measured and may be used to determine if changes have occurred at end-of-travel. Deviations from zero or span endpoints are graphically portrayed to alert maintenance staff of worn end-stops.

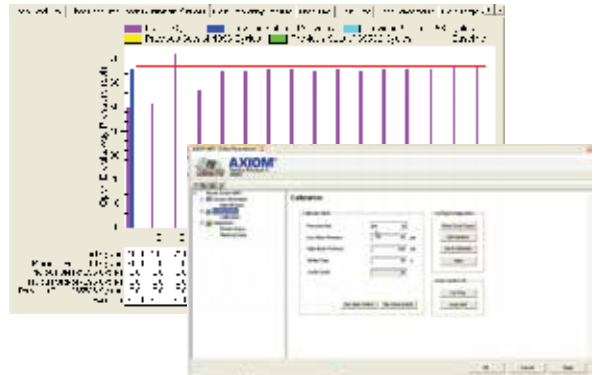

Easy control system integration

System connections

Two, 2-wire connections attach to the control system to provide discrete solenoid control and continuous position monitoring. A standard 24 VDC discrete output (DO) powers and controls the solenoid valve. Intrinsically safe solenoid pilot may also be selected. A conventional 4-20 mA analog input (AI) provides continuous exact valve position feedback into the control system.

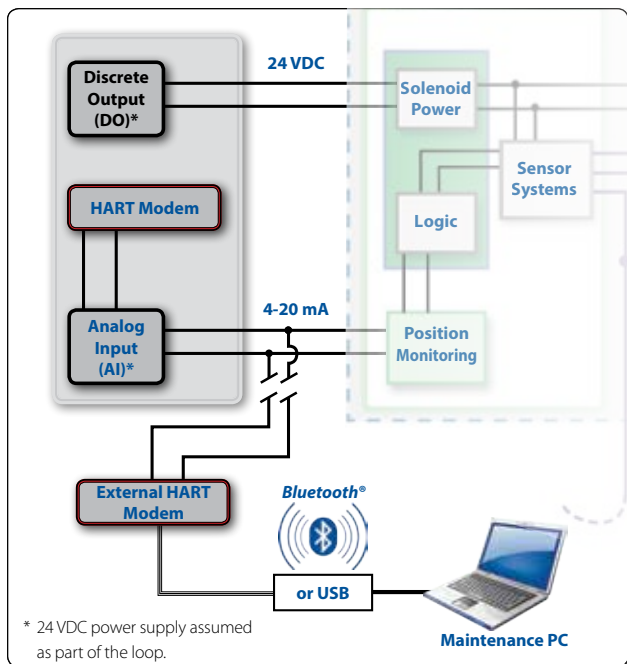

HART signal

The HART communication signal is overlaid on the 4-20 mA analog position monitoring input. The signal may be read via internal modem in the DCS system or external modem. External modems may transmit information to a DCS or to a remote PC via a hardwired or a wireless connection.

Software integration

Integration to various DCS or asset management systems may be achieved using open, standardized technologies such as enhanced EDDL (Electronic Device Description Language) or FDT/DTM (Field Device Tool/Device Type Manager). Most DCS vendors use one or both of these technologies, which provides open access to device intelligence and allows easy use of all features and benefits available from the Axiom HART device.

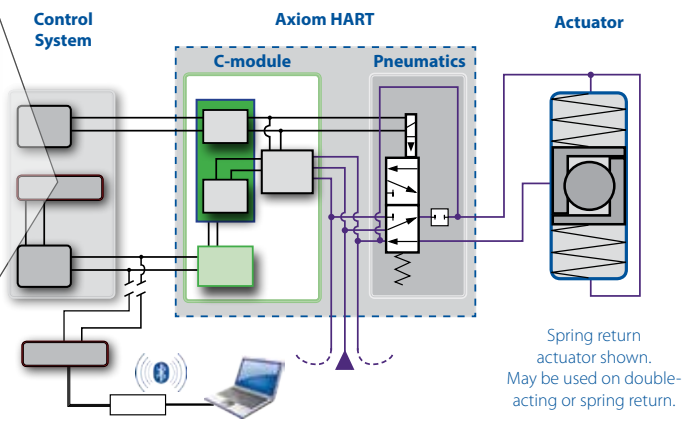

Axiom Expeditor

Improve process performance and prevent damage to equipment with intermediate control

With expanded control and monitoring capabilities, the Axiom Expeditor offers unparalleled value in batch processing applications. Below are a few examples of applications where the Axiom Expeditor may improve your plant operation.

Fill control

Fill tanks and hoppers rapidly and accurately. You can set the Axiom Expeditor to partially close the valve to reduce flow as the full level approaches. You get fast, economical "topping off" of every batch with a single valve sized for high flow rates, which may be throttled back at the end of the fill cycle.



Flow dampening

The Axiom Expeditor allows valves to close using multiple steps, which inhibits water hammer resulting from a sudden full closure. You get prolonged valve and piping life, improved process flow performance and less potential for catastrophic failure.

Thermal shock reduction

By partially opening a standard discrete valve, steam lines are heated gradually; thus preventing thermal shock. Once lines are heated, full opening may occur minimizing any potential damage to steam lines. This is especially critical in CIP (clean-in-place) and SIP (steam-in-place) applications.

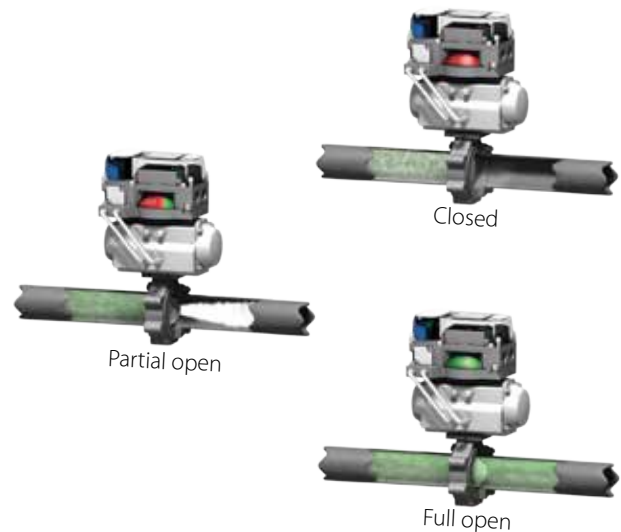

Fast, convenient set-up

Calibration may be performed quickly and easily using the Axiom Expeditor's readily accessible membrane control pad. By simply following the on-board instructions, with the unit powered up, all set-up procedures may be performed in a few easy steps and the actuator evaluated for proper stroke timing.

During set-up, as mentioned above, the Axiom Expeditor automatically gages the speed of the actuator to determine if flow restrictors are needed. If full stroke is less than one second, flow restrictors (included with each Expeditor from the factory) are required to assure smooth, consistent intermediate control operation.



Simple operation and control system integration

- Full open and closed cycling is performed by energizing and de-energizing the discrete 24 VDC output (DO) from the control system.
- A preset intermediate position may be achieved by maintaining power from the discrete output (DO) and switching on the analog output (AO) at a preset level between 4 and 20 mA.
- Intermediate control is achieved by maintaining power from the discrete output (DO) and energizing the control system's analog output (AO). By changing the AO signal, the Axiom control output will toggle the solenoids to the desired position within $\pm 4\%$ of full scale.
- The valve/actuator operates to the fail-safe position whenever the discrete output (DO) is de-energized.

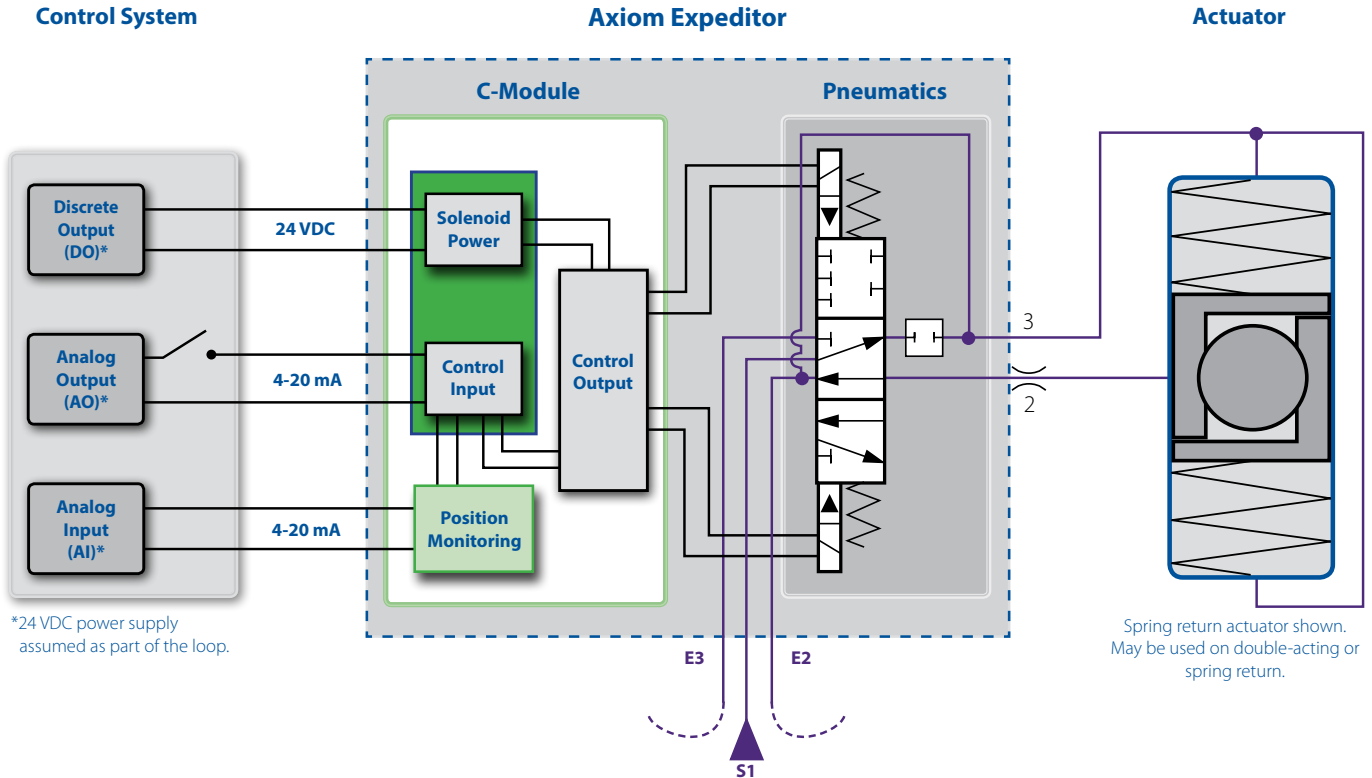

Expeditor specifications																												
Expeditor (80)																												
Position feedback control (AI)	4-20 mA loop, 9 - 35 VDC																											
Intermediate position control (AO)	4-20 mA loop, 9 - 35 VDC																											
Position monitoring accuracy	+/- 1° of rotation																											
Intermediate control accuracy	+/- 3° of rotation																											
Solenoid voltage	24 VDC (conventional models) 12 VDC (Intrinsic safety models)																											
Wiring diagram																												
(80)																												
Expeditor																												
Specify pneumatic valve option 2D or 2E																												
	<table border="0"> <tr> <td></td> <td>Secondary -</td> <td>⊗</td> </tr> <tr> <td>Solenoid Valve</td> <td>Secondary +</td> <td>⊗</td> </tr> <tr> <td></td> <td>Primary -</td> <td>⊗</td> </tr> <tr> <td>Solenoid Valve</td> <td>Primary +</td> <td>⊗</td> </tr> <tr> <td></td> <td>Solenoid Power -</td> <td>⊗</td> </tr> <tr> <td></td> <td>Solenoid Power +</td> <td>⊗</td> </tr> <tr> <td rowspan="4">4-20 mA</td> <td>Position Feedback -</td> <td>⊗</td> </tr> <tr> <td>Position Feedback +</td> <td>⊗</td> </tr> <tr> <td>Control -</td> <td>⊗</td> </tr> <tr> <td>Control +</td> <td>⊗</td> </tr> </table>		Secondary -	⊗	Solenoid Valve	Secondary +	⊗		Primary -	⊗	Solenoid Valve	Primary +	⊗		Solenoid Power -	⊗		Solenoid Power +	⊗	4-20 mA	Position Feedback -	⊗	Position Feedback +	⊗	Control -	⊗	Control +	⊗
	Secondary -	⊗																										
Solenoid Valve	Secondary +	⊗																										
	Primary -	⊗																										
Solenoid Valve	Primary +	⊗																										
	Solenoid Power -	⊗																										
	Solenoid Power +	⊗																										
4-20 mA	Position Feedback -	⊗																										
	Position Feedback +	⊗																										
	Control -	⊗																										
	Control +	⊗																										

Expeditor specifications	
Cycle life	500,000 cycles (full cycles with intermediate position; cycle life may vary depending on intermediate toggling) <i>Cycle life may be extended by installing solenoid spool service kit.</i>
Temperature rating	-18° to 50° C (0° to 122° F) Extended temperature when -T suffix specified -20° to 80° C (-4° to 176° F)
Supply pressure	40 psi (2.7 bar) minimum 120 psi (8.2 bar) maximum
Solenoid power	0.5 watt (0.02A @ 24 VDC) 0.5 watt Intrinsically Safe (I.S.) (0.04A @ 12 VDC)



Axiom AMI with Wireless Link

Easily access hard-to-reach automated valves

Discover convenient remote access of your automated valves when you install the Axiom AMI with AS-Interface featuring *Bluetooth*® technology.

Devices may be remotely accessed from up to 50 meters depending on obstructions. Setting changes and solenoid control are enabled through the AS-Interface network or by the power supply jumper.

With the new patent pending *StoneL Wireless Link* app you can remotely:

- Monitor and set open and closed switch positions
- Monitor and set the network address
- Operate solenoid valve(s) (if network- or power supply-enabled)
- Identify model and serial number (preset from factory)
- Identify valve automation components (entered by valve supplier)
- Log maintenance information
- Monitor diagnostics (valve cycle count, electronics temperature, and more).



Interfacing devices

Conventional Apple® devices may be used including:

- iPhone® Version 4S and above
- iPad® Version 3.0 and above
- iPad mini™ All

Contact StoneL regarding additional devices and special enclosures to make these devices suitable for use in hazardous locations.



Set up and operation

The Axiom AMI with Wireless Link is commissioned and set up identically to the standard AS-Interface unit. In addition, when powered up with a conventional power source or by the network, it may be accessed by standard iOS devices. The Axiom is accessed with the *Bluetooth*® Smart protocol using the StoneL Wireless Link application. Sequence of operation is:

1. Download the StoneL application from the App Store onto your device (free of charge)
2. Start the application in your Apple® device
3. All energized wireless modules in range will come up
4. Push wink to positively confirm the device you have linked (Axiom LEDs will flash)
5. Touch the specific Axiom ID/tag to link with your handheld.

You can then monitor all status and diagnostic information and make necessary information changes to the free form fields at any time. Switch settings, address changes, and solenoid operation may be performed only if network- or power supply-enabled. Other information may also be added to the free form fields.



Benefits of Wireless Link

- Fast, convenient set-up** for valve automation suppliers without special equipment.
- Electronically enter and store** key automated valve system information including:
 - End user tag number/information
 - Valve and actuator identification as well as Axiom model and serial number (Axiom information preset from factory)
 - Maintenance log.
- Improve safety by easily accessing hard-to-reach automated valves** without putting plant personnel at risk.
- Reduce network commissioning time** by accessing the VCT address and making changes if necessary.
- Reduce maintenance time** by monitoring valve cycle count, storing maintenance logs, and accessing multiple valves from one location.
- Conveniently retrieve installation manuals** and StoneL website when connected to internet.

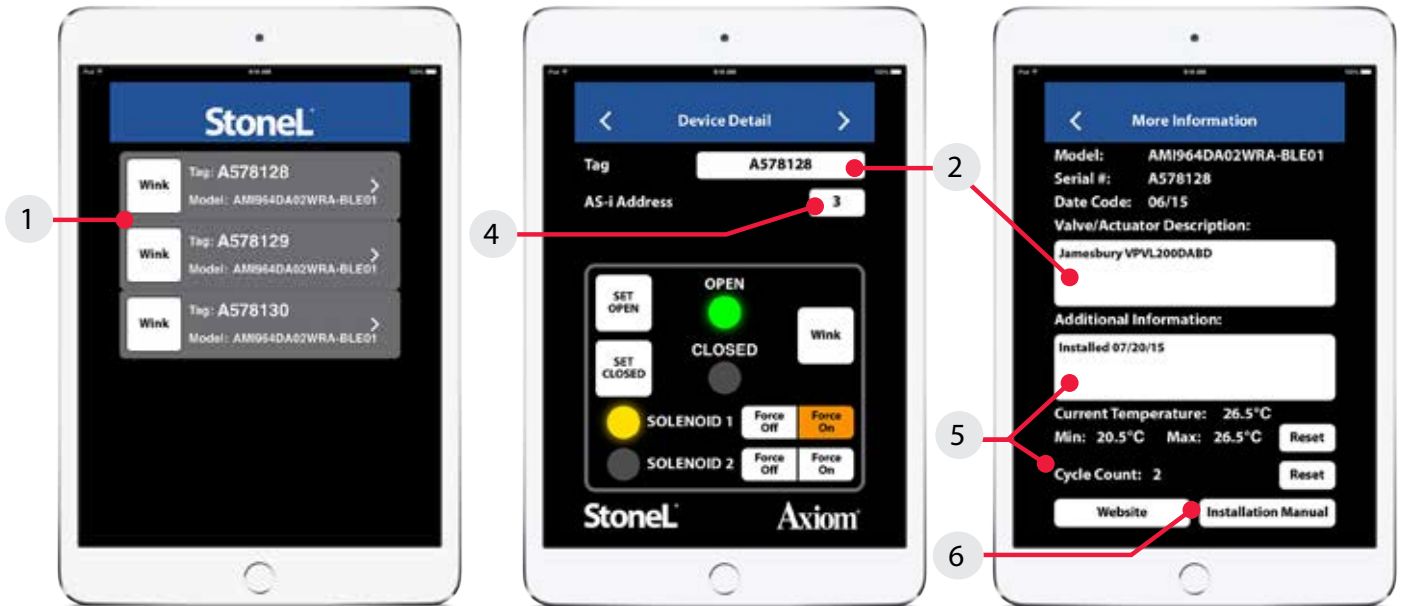

Specifications	
Standard specifications apply to Axiom AMI96_ _ _ _ _W_ _ models and AMI97. Additional specifications for Wireless Link are as follows:	
Protocol	Bluetooth® Smart technology; Single mode (not compatible with Bluetooth® Classic)
Transmit power	4 dBm or ~2.5 milliwatts
Data rate	1Mbit/second; effective information transmit rate ~10 Kbits/second
Range	Up to 100 meters (330 feet) in free space. Range is reduced by obstructions between handheld device and Wireless Link VCT. Line of sight is not necessary.
Registrations	FCC, IC, CE
CE compliance	Exceeds industrial compliance standards
VCT identification	VCTs in range will be displayed
VCT link	One device accessed at a time between client (handheld device) and server (VCT). Each server accessed by one client at a time.
Application	"StoneL Wireless Link" available from the App store
Handhelds	Compatible with iPhone® and iPad® with iOS 8 or later

AS-Interface with Wireless Link (AMI96_ _ _ _ _W_ _ models and AMI97)	
Configuration	(2) Discrete sensor inputs (2) Auxiliary discrete inputs (2) Power outputs (solenoids)
Maximum current	170 mA
Auxiliary inputs	24 VDC @ 2 mA (self-powered)
Output	4 watts @ 24 VDC
Output, voltage	24 VDC (+/- 10%)
Configuration code	AMI96 ID=F; IO=4 (4DI/2DO) AMI97 ID=A; IO=7 (4DI/2DO)
AS-i version	3.0
Devices per network	AMI96 31 AMI97 62
Wiring diagram	
(96) and (97) with Wireless Link (W)	
Specify solenoid option _D	

Model selector

SERIES

AMI Nonincendive or intrinsically safe

FUNCTIONS

Sensor modules

- 33 SST NO sensor *[select pneumatic valve option _H]*
- 35 SST 240V Universal (NO sensor) *[select pneumatic valve option _H]*
- 44 NAMUR sensors intrinsically safe (EN 60947-5-6; I.S.) *[select pneumatic valve option _E]*
- 80 Expeditor *[select pneumatic valve option 2D, 4D, 2E or 4E]*

Valve communication Terminals (VCTs)

- 71 4-20 mA with HART diagnostics *[select pneumatic valve option 1D, 3D, 5D, 1E, 3E or 5E with Diagnostics Capabilities option "D"]*
- 92 DeviceNet™ *[select pneumatic valve option _D]*
- 93 Foundation Fieldbus (bus powered; I.S.) *[select pneumatic valve Piezo option _A]*
- 96 AS-Interface *[select pneumatic valve option _D with capabilities option "S" or "W" or pneumatic valve single pilot option 1D, 3D or 5D with capabilities option "D"]*
- 97 AS-Interface with extended addressing *[select pneumatic valve option _D with capabilities option "S" or "W"]*

PNEUMATIC VALVE

No external override

- 1H Single pilot, universal voltage solenoid
- 1J Single pilot, 240 VAC (4.5 watts)
- 1D Single pilot, 24 VDC (0.5 watt)
- 1E Single pilot, 12 VDC intrinsically safe
- 1B Single pilot, 1.8 W 24 VDC
- 2H Dual pilot, universal voltage solenoid
- 2D Dual pilot, 24 VDC (0.5 watt)
- 2E Dual pilot, 12 VDC intrinsically safe
- 1A Single piezo, intrinsically safe or standard
- 2A Dual piezo, intrinsically safe or standard

External override

- 3H Single pilot, universal voltage solenoid
- 3J Single pilot, 240 VAC (4.5 watts)
- 3D Single pilot, 24 VDC (0.5 watt)
- 3E Single pilot, 12 VDC intrinsically safe
- 3B Single pilot, 1.8 W 24 VDC
- 4H Dual pilot, universal voltage solenoid
- 4D Dual pilot, 24 VDC (0.5 watt)
- 4E Dual pilot, 12 VDC intrinsically safe
- 3A Single piezo, intrinsically safe or standard
- 4A Dual piezo, intrinsically safe or standard

Latching external override

- 5H Single pilot, universal voltage solenoid
- 5J Single pilot, 240 VAC (4.5 watts)
- 5D Single pilot, 24 VDC (0.5 watt)
- 5E Single pilot, 12 VDC intrinsically safe
- 5B Single pilot, 1.8 W 24 VDC
- 5A Single piezo, intrinsically safe or standard

ENCLOSURE

- A North American (NEC/CEC)
- V International (IEC)
- L Brazilian
- * Aluminum cover available *[consult factory for special suffix]*

CONDUIT/CONNECTORS

Standard

- 02 (2) ½" NPT
- 05 (2) M20

Mini-connectors

- 10 (1) 4-pin
- 11 (1) 5-pin
- 19 (1) 6-pin
- 20 (1) 7-pin
- 21 (1) 8-pin

Micro-connectors

- 13 (1) 4-pin
- 15 (1) 5-pin
- 17 (1) 6-pin
- 18 (1) 8-pin

CAPABILITIES

- S Standard
- D Diagnostics *[available with Function 96 or 71; single pilot only]*
- W Wireless Link (patent pending) *[available with Function 96 or 97; single or dual pilot]*

VISUAL INDICATOR *[see chart on page 29]*

- RA Red closed/green open
- GA Green closed/red open
- 1A Three-way flow path
- 2A Three-way flow path
- XA Special

Model number example

AMI 96 1D A 02 W RA - OPTIONAL OR -T

MODEL NUMBER

Mounting hardware required and sold separately.

PARTNERSHIP ID

Some models may include 5-digit identification suffix.

TEMPERATURE*

Specify -T suffix for extended temperature.

***Special notes**

Extended temperature range for function "80" (Expeditor): -20°C to 80°C. Extended temperature is not an option for Function 93 and Piezo

Specifications

Materials of construction

Housing and mounting manifold	Epoxy-coated anodized aluminum
Visual indicator	Lexan® polycarbonate
Fasteners and mounting adaptors	316 stainless steel
Pneumatic valve	See pneumatic valve specifications on page 24.

Temperature ratings (pneumatic valve dependent)

Piezo pilots (_A)	-10° to 60° C (14° to 140° F)
Solenoid pilots (_D, _E, and _H)	-18° to 50° C (0° to 122° F) <i>Extended temperature when -T suffix specified</i> -40° to 80° C (-40° to 176° F)

Position sensor system

Accuracy	Within 1°
Repeatability	Within 1°
Setting buffer	4° from setpoint <i>Rotational distance from original setpoint where switch will energize on return stroke.</i>
Deadband	6° from setpoint <i>Rotational distance from original setpoint where switch will de-energize.</i>
Maximum rotational range	120°

Operating life

Pneumatic valve	1 million cycles <i>Cycle life may be extended by installing solenoid spool service kit.</i>
-----------------	---

Warranty

Mechanical components	Two years
Electronic components	Five years

Ratings

Nonincendive <i>(Ex n, Zone 2 or Class I and II, Div. 2)</i>	AMI models*
Intrinsically safe <i>(Ex ia, Zone 0 or Class I and II, Div. 1)</i>	Functions 44 and 93*

Enclosure protection

NEMA 4, 4X and 6	All models
Ingress Protection 67	All models

Approvals*

See Stonel.com/approvals

* Only models listed on Stonel's official website are approved per specific rating.

Dimensions Inches [mm]

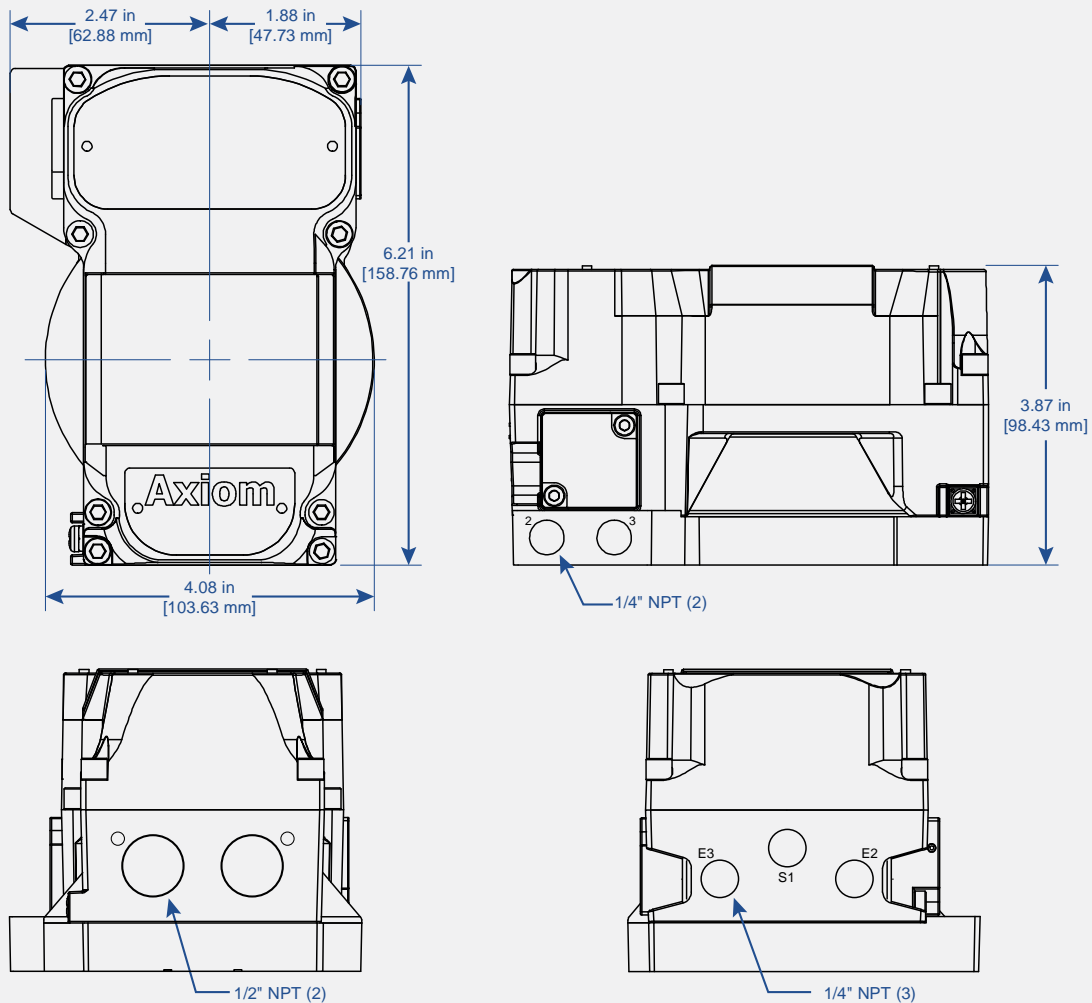



26271 US Highway 59, Fergus Falls, MN 56537 USA
Tech hotline +1 218 737 0701
Tel. +1 218 739 5774
Email: sales@stoneL.com

StoneL.com

Publication Number
S-912-12/20

Subject to change without prior notice. Neles, Jamesbury and Easyflow by Neles, StoneL, and certain other trademarks, are either registered trademarks or trademarks of Neles Corporation or its subsidiaries or affiliates in the United States and/or in other countries. For more information www.neles.com/trademarks