

Jamesbury™ 6" WSRR/WSRF bottom unloading Wafer-Sphere™ butterfly valves for tank car applications (AAR no. E182107)

The Wafer-Sphere tank car butterfly valve is the most compact valve available for tank car service. This valve offers low installation cost with minimum skidding requirements, 100% unloading capability, and easy maintenance.

The low profile of these valves requires one-third the skid height necessary for conventional bottom outlet valves. Because the valve does not project into the tank shell, it allows for 100% unloading.

Wafer-Sphere tank car valves provide long-lasting, reliable shutoff and considerable dollar savings. In addition to the standard WSRR, the valve is also available in a design approved for use with food products such as corn syrup. Designated WSRR 36HB TT6KT, the valve is constructed of stainless steel, has a polished disc, and is fully passivated.

Features

Unique sealing

Derived from the unique lip-seal in the Jamesbury ball valve, the seat in the Wafer-Sphere tank car valve provides tight sealing between PTFE and metal. The flexible one-piece PTFE seat automatically compensates for wear and for temperature changes, furnishing the valve with the capability to withstand the most rugged tank car services.

Materials

Available in stainless steel as standard, Wafer-Sphere tank car valves handle an extremely wide range of media. Other materials are available on application.

Fire-Tite™ design

Wafer-Sphere butterfly tank car ball valves are available with Fire-Tite design. In the event of a fire resulting in partial or complete destruction of the PTFE seats, a secondary metal sealing surface provides continuous effective shutoff.

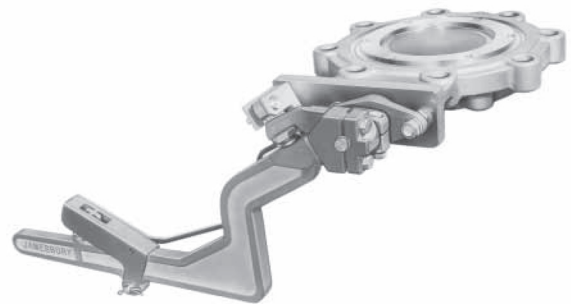

Specifications

Flow data

The 6" WSRR/WSRF valve has an installed CV value of 980. CV is defined as the flow of water through the valve in U.S. gallons per minute at a pressure drop of 1 psi. The metric equivalent, KV, is the flow of water at 16°C through the valve in cubic meters per hour at a pressure drop of 1 kg/cm². To convert CV to KV, multiply by 0.8569. This CV value is an estimate of the installed flow capacity and considers typical inlet losses.

Ratings

WSRR/WSRF valves are rated for pressures and temperatures well in excess of those normally encountered. 316 stainless-steel valves are rated from -60°F to +500°F (-51°C to +260°C). The pressure rating is 285 psi.

Service

Representative stocks of Wafer-Sphere valves are maintained by the Valmet network of authorized stocking distributors located in key areas of the United States and Canada. They will be happy to assist you in the selection of the most cost-effective valve for your application. For the distributor, visit our web site at www.valmet.com/flowcontrol.

Dimensions – inches (mm)

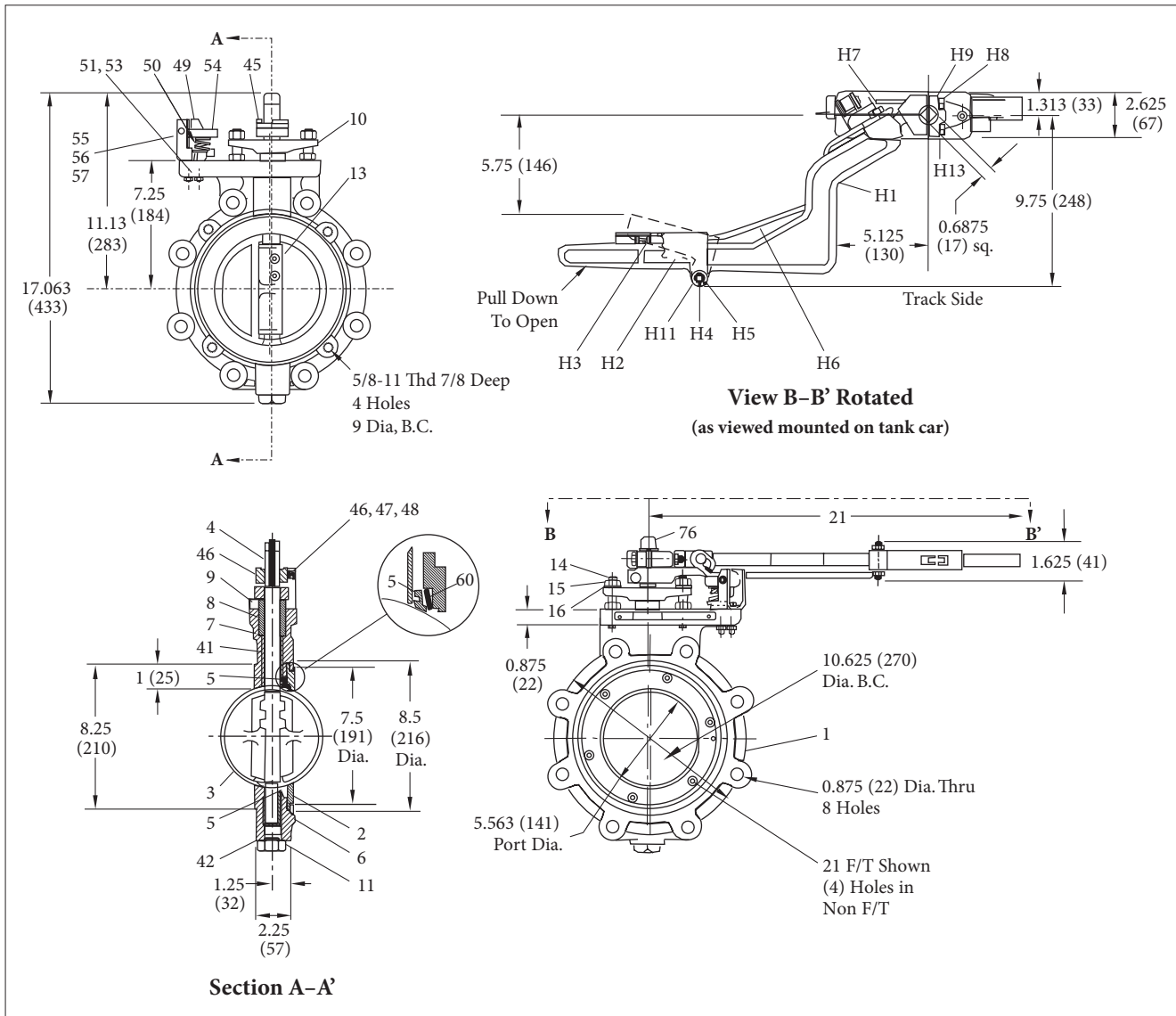

Bill of materials and parts list		
Part no.	Part name	Body material
		316 Stainless Steel (36HB)
1	Body	316 Stainless steel ASTM A351 Type CF8M
2	Body Insert	316 Stainless steel
3	Disc	316 Stainless steel
4	Shaft	17-4PH Stainless steel
5	Seat	PTFE or Filled PTFE (WSRR) or PTFE/17-4PH (Part No. 60) Stainless steel (WSRF)
6	Shaft Bearing	PTFE/316 Stainless (WSRR) or Rulon®/316 Stainless (WSRF)
7	Spacer	Stainless steel
8	Shaft Seal	PTFE (WSRR) or graphite (WSRF)
9	Compression Ring	Stainless steel
10	Compression Plate	316 Stainless steel
11	Pipe Plug	316 Stainless steel
13	Pin	17-4PH Stainless steel, 316 Stainless steel*
14	Stud	Carbon steel cadmium plated
15	Jam Nut	Carbon steel cadmium plated
16	Lock Washer	Carbon steel
17	Nameplate	Stainless steel
18	Drive Screw	Stainless steel
21	Socket Head Cap Screw	Hex head cap screw for food service – Stainless steel
27	Retaining Ring	Inconel®
28	Centering Device	Delrin®
29	Bottom Bearing Spacer	PTFE
41	Top Bearing Spacer	PTFE
43	Tag	Paper
45	Lock Arm	Carbon steel
46	Head Cap Screw	Carbon steel
47	Lock Washer	Carbon steel
48	Nut	Carbon steel cadmium plated
49	Spring Stand	Carbon steel
50	Latch Spring	Stainless steel
51	Hex Head Cap Screw	Carbon steel cadmium plated
53	Centerlock Nut	Carbon steel cadmium plated
54	Latch Pawl	Stainless steel
55	Clevis Pin	Stainless steel
56	Flat Washer	Carbon steel cadmium plated
57	Cotter Pin	Stainless steel
60	Sealing ring	17-4PH
76	Retaining Ring	Carbon steel
WEIGHT (valve and handle): 62 lbs. (28 kg)		

Rulon is a Registered Trademark of Dixon Industries Corporation of America.

* Food service only

Part no.	Part name	Body material
H1	Handle	Ductile iron
H2	Gripper Handle	Carbon steel
H3	Compression Spring	Carbon steel
H4	Clevis Pin	Stainless steel
H5	Washer	Carbon steel
H6	Latch Wire	PTFE Coated ENP Carbon Steel
H7	Shoulder Screw	Carbon steel
H8	Cap Screw	Carbon steel
H9	Lock Washer	Carbon steel
H11	Cotter Pin	Stainless steel
H13	Handle Cap	Carbon steel

How to order Wafer-Sphere valves

To specify one of these valves, it is necessary only to select the proper body material to meet a specific service requirement. All other components are of materials appropriate for the most severe conditions.

The catalog designations below fully describe a valve, identifying body and trim materials. The codes are:

Standard Wafer-Sphere valves

Stainless Steel Body and Trim

6" WSRR – 36HBTT5

For Food Grade Service

Stainless Steel with Pressed Pins and Full Passivation

6" WSRR – 36HBTT6KT

Fire-Tite Wafer-Sphere valves

Stainless Steel Body and Trim

6" WSRF – 36HBTL5

To order a Service Kit for these valves, specify RKR32 TT or MT for standard valves, or RKR35 TL or ML for Fire-Tite valves.

Subject to change without prior notice.

Neles, Neles Easyflow, Jamesbury, Stonel, Valvcon and Flowrox, and certain other trademarks, are either registered trademarks or trademarks of Valmet Oyj or its subsidiaries in the United States and/or in other countries.

For more information www.neles.com/trademarks

Valmet Flow Control Oy

Vanha Porvoontie 229, 01380 Vantaa, Finland.

Tel. +358 10 417 5000.

www.valmet.com/flowcontrol

