

Stonel™ Prism™ linear on/off sanitary diaphragm valve controller Series PI





Intelligent features offer advanced performance

The Prism series integrates an advanced position sensing system and integral pneumatic control for sanitary diaphragm and other linear applications. Compact and durable, the units are suited for corrosive, heavy washdown and hazardous areas.

Advanced position sensing

With the continuous solid state mag res sensor system, the Prism series offers the ultimate in ease of set-up, reliability and consistent performance. Push button or remote setting is simple and quick with bold mechanical, as well as LED visual position status.

Integral pneumatic control in compact, vapor tight enclosure

Position sensing system and control valve are enclosed in a vaportight submersible enclosure with convenient screw on cover access. Pneumatic solenoid valve is available in standard high flow. Settings and wiring may be conveniently accessed for quick set-up and maintenance.

Compact design for convenient adaptability to linear valves

The PI offers precision feedback for valve stroke lengths varying from 4 mm (0.13") up to 66 mm (2.6"). Options include three cover heights, the low profile version with no visual indicator and a medium or tall cover version both with a visual indicator. With the low profile version, the unit is less than 76 mm (3") above actuator mounting pads and may accommodate stroke lengths up to 28 mm (1.1").



Features

1. **Suitable for high pressure washdown** and temporary submersion, the PI is rated for Type 4, 4X and 6 (IP66 & 67).
2. **Screw-on cover** enables convenient access without tools.
3. **Enclosure is made of high impact strength**, corrosion-resistant polycarbonate.
4. **Prominent visual indicator** boldly displays mechanical position status.
5. **Low profile design** minimizes height clearance required above actuator.
6. **All electronics are sealed** inside the linear C-module to protect against contamination, shock and vibration.
7. **Intelligent high accuracy position sensor** is solid state with no moving parts for long life. Sensor automatically adjusts dead band based on stroke length.
8. **Integral solenoid valve** available with Cv of 0.20.
9. **NPT pneumatic connections** are stainless steel reinforced for long life sealing under high torque stress conditions.
10. **Push button open and closed** settings are made conveniently and quickly. (AS-Interface unit may have settings made remotely.)
11. **LED light bar** brightly displays open, closed and solenoid status.
12. **Conduit entries** available in NPT, metric threads or quick connectors.

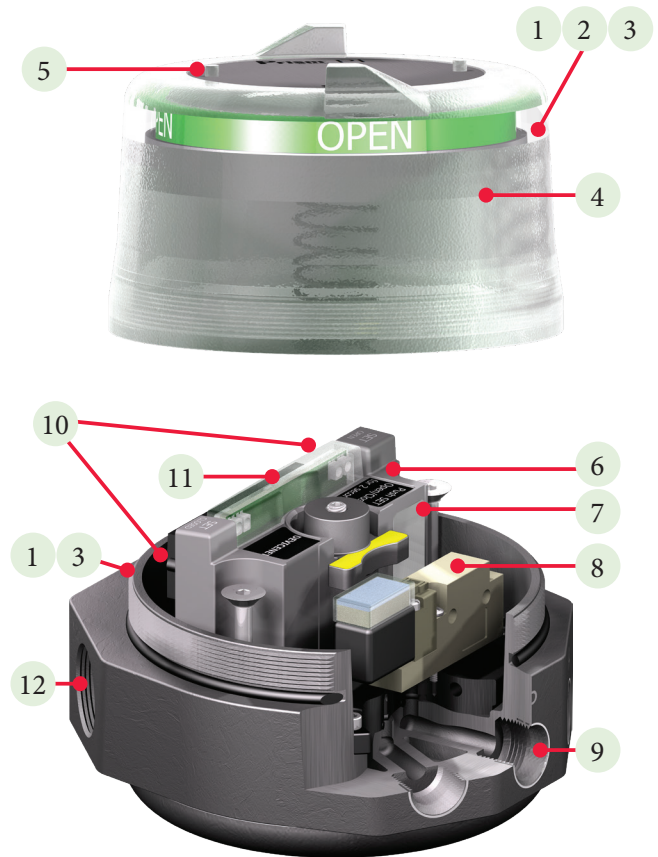

Prism mounting system

Prism adapting systems are designed for each actuator using a standardized system that minimizes the required space envelope. Mounting components include:

- Standardized rugged mounting plate allowing for rotational flexibility and compact secure attachment.
- Actuator fasteners made of stainless steel and tailored for each specific mounting application.
- Shaft coupler made of stainless steel and designed to conveniently attach the magnetic trigger to actuator shaft.

Complete mounting adaption is performed in minutes! With no moving wear-parts long-life is assured. And, the trigger system is impervious to thermal shock and vibration.

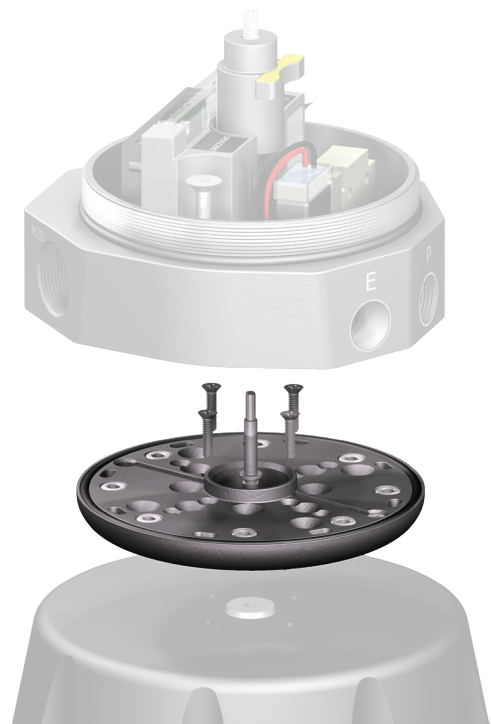

Position sensor module

The PI features an intelligent linear magnetic resistive sensor system to precisely measure stroke position at all times.

- High accuracy over wide operating temperature range.
- Automatic tuning of open and closed deadband depending on stroke length (See below).
- High intensity LEDs in module light bar which reflect on enclosure cover for visibility of switch status even in brightly lit areas.
- Fully potted and sealed making it resistant to high G vibration forces and moisture.
- Convenient, simple push button settings accurately locking in open and closed positions, which remain in place when power is removed and reapplied.

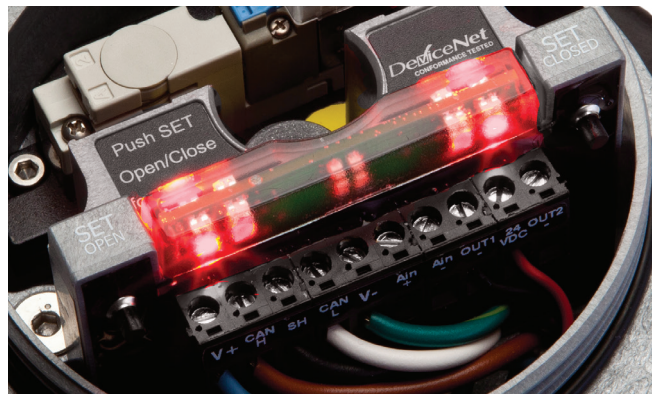

Convenient push button settings and high intensity LEDs

Automatic tuning

The intelligent sensing system offers precise feedback. Set-up is performed in seconds with high precision in the closed position and no false switching in varying open positions.

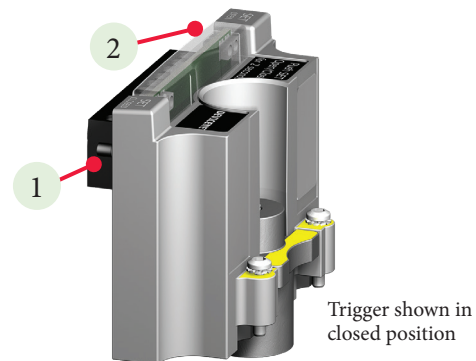

Trigger shown in closed position



Trigger shown in open position

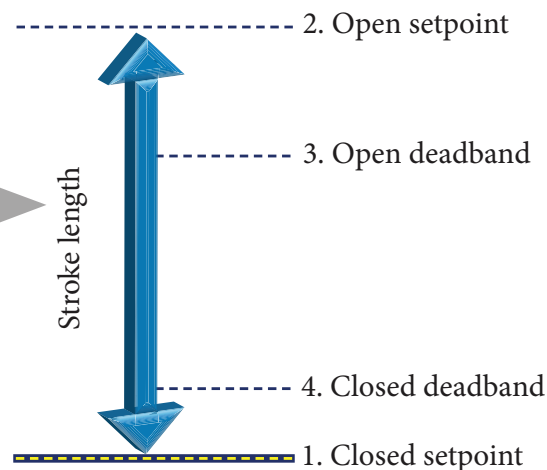

Easy set-up

1. Push button to set closed (2 seconds).
2. Push button to set open (2 seconds).
3. Open deadband is automatically set to 30% of full stroke length, eliminating false switch feedback from “floating” due to pressure variations.
4. Closed deadband is automatically set to 3.8 mm (0.150”), or 30% of stroke, whichever is less, providing precise closed indication.

Sensing and communication module

The Prism features our linear module system with field proven reliability in all on/off applications. Outputs are available as SST (switching) and VCTs (valve communication terminals).

Modules have a **five year warranty**.



Switching and sensor specifications

SST switching sensors (33)

Configuration	Linear solid state sensors (2) Wire terminations for one solenoid
Operation	Select NO (33) model
Maximum current inrush	1.0 amp @ 125 VAC/VDC
Maximum current continuous	0.10 amp @ 125 VAC/VDC
Minimum on current	2.0 mA
Maximum leakage current	0.5 mA
Voltage range	20 - 125 VAC/VDC
Maximum voltage drop	6.5 volts @ 10 mA 7.5 volts @ 100 mA

Wiring diagram (33)

SST

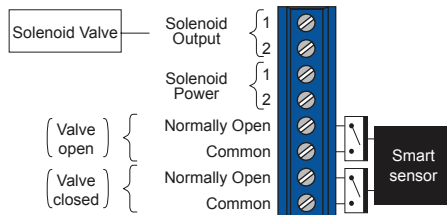

Sensor specifications

NAMUR sensor (45)

Configuration	(2) NAMUR sensors (EN 60947-5-6; I.S.) Wire terminations for one solenoid
Operation	Normally closed NAMUR sensors (solid state)
Voltage range	5 - 25 VDC
Current ratings	Target on I<1 mA Target off I>3 mA

Wiring diagram (45)

NAMUR

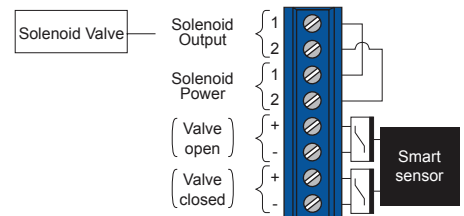

Valve Communication Terminal (VCT) specifications

DeviceNet™ (92S & 92W)

Configuration	92W 92W	(2) Discrete inputs (open and closed) (2) Remote sensor settings (1) Wink feature (2) Power outputs (solenoids) (1) 4-20 mA auxiliary analog input, 10-bit resolution; no additional power source required
Transmission rate	Software selectable 125K, 250K or 500K baud	
Messaging	Polling, cyclic and change of state	
Outputs	4 watts @ 24 VDC both outputs combined	
Output voltage	24 VDC (with input voltage ranging from 10 - 24 VDC)	
Other features	Predetermined output fail state	

Wiring diagram (92S & 92W)

DeviceNet™

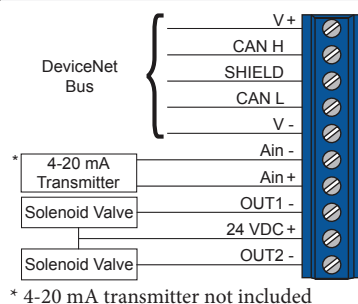

* 4-20 mA transmitter not included

Valve Communication Terminal (VCT) specifications

AS-Interface (96S) and AS-Interface with extended addressing (97S & 97W)

Configuration		(2) Discrete sensor inputs (1) Power output (solenoid)
Maximum current	167 mA	
Output voltage	21 - 26 VDC	
Profile	96 97	ID=F, IO=7; (4DI/4DO) ID=A, IO=7; (4DI/3DO)
AS-i version	3.0	
Devices per network	96 97	31 62
Features	96 97	Wink and remote setting Wink

Wiring diagram (96S) and (97S & 97W)

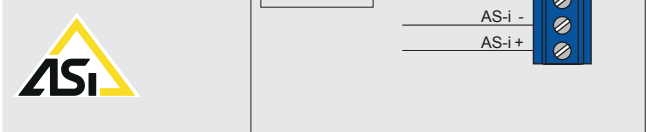

Prism PI with Wireless Link

Easily access hard-to-reach automated valves

Discover convenient remote access of your automated valves when you install the Prism PI with AS-Interface and DeviceNet featuring *Bluetooth®* technology. Devices may be remotely accessed from up to 50 meters depending on obstructions. Setting changes and solenoid control are enabled through the DeviceNet or AS-Interface network or by the AS-Interface power supply jumper.

Special features

- Improve safety by easily controlling hard-to-reach automated valves without putting plant personnel at risk.
- Look up factory preset module code and serial number remotely.
- Electronically enter and store key automated valve system information including user tag and maintenance log.
- Reduce network commissioning time by accessing the VCT address and baud rate to make changes.
- Reduce maintenance time by monitoring valve cycle count, cycle times, storing maintenance logs, and accessing multiple valves from one location.
- Conveniently retrieve installation manuals for additional technical information when connected to internet.



Customize the tag for a device, change the address, force the solenoids on or off, wink the device, and set the valve limits.

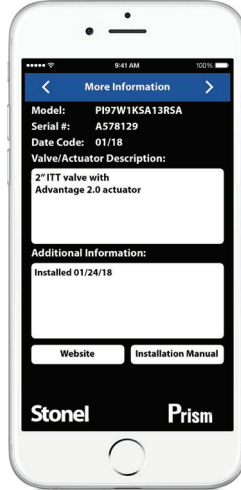

Store and view additional information about a specific valve.

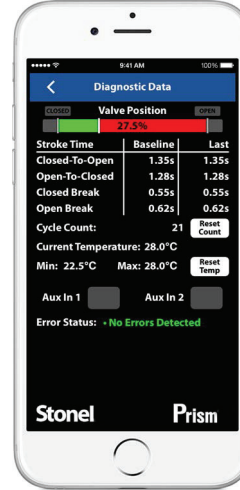

View real time valve position, cycle count, cycle timing, current valve temperature, error status, and more.

Interfacing devices

Conventional Apple® devices may be used including:

- iPhone® Version 4S and above
- iPad® Version 3.0 and above
- iPad mini™ All

Contact factory regarding additional devices and special enclosures to make these devices suitable for use in hazardous locations.



Set up and operation

Devices with Wireless Link are commissioned and set up identically to the standard AS-Interface or DeviceNet unit. In addition, when powered up with a conventional power source or by the network, it may be accessed by standard iOS devices. The Axiom is accessed with the Bluetooth® protocol using our Wireless Link application. Sequence of operation is:

1. Download the Stonel application from the App Store onto your device (free of charge)
2. Start the application in your Apple® device
3. All energized wireless modules in range will come up
4. Push wink to positively confirm the device you have linked (device LEDs will flash)
5. Touch the specific ID tag to link with your handheld.

You can then monitor all status and diagnostic information and make necessary information changes to the free form fields at any time. Switch settings, address changes, and solenoid operation may be performed only if network- or power supply-enabled. Other information may also be added to the free form fields.

Specifications for Wireless Link

Standard specifications apply to Prism PI92W & PI97W. Additional specifications for Wireless Link are as follows:

Communication	Bluetooth® technology; single mode (not compatible with Bluetooth Classic)
Transmit power	4dBm or ~2.5 milliwatts
Data rate	1 Mbit/second; effective information transmit rate ~10 Kbits/second
Range	Up to 100 meters (330 feet) in free space. Range is reduced by obstructions between hand-held device and Wireless Link VCT. Line of site is not necessary.
Registrations	FCC, IC, CE
CE compliance	Exceeds industrial compliance standards
VCT identification	VCTs in range will be displayed
VCT link	One device accessed at a time between client (hand-held device) and server (VCT). Each server accessed by one client at a time
Application	Stonel Wireless Link available from the App store
Hand-helds	Compatible with iPhone® and iPad® with iOS 9 or later

Wireless Link enabled network

All settings and inputs are locked when standard network communication is functioning. For fast commissioning and asset management you can import and export electronic tags, model number, serial number, device address, descriptive fields, diagnostic data and more to and from standard CSV/Excel® files.

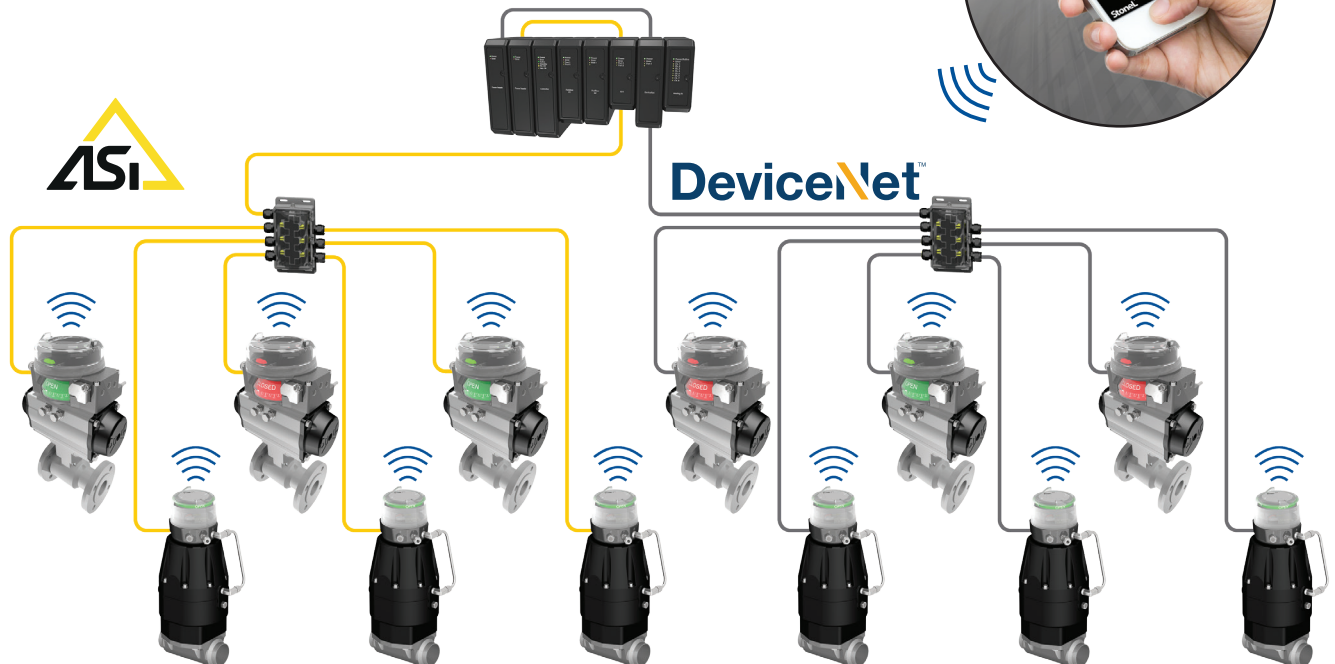

Expeditor

The Prism Expeditor features an intelligent linear magnetic resistive sensor system to precisely measure stroke position at all times and provides control signals to the solenoid control.

- High accuracy over wide operating temperature range.
- Automated teach function to tune control algorithm to the specific actuator.
- High intensity LEDs in module light bar which reflect on enclosure cover for visibility of switch status even in brightly lit areas.
- Fully potted and sealed making it resistant to high G vibration forces and moisture.
- Convenient, simple push button teach settings may be done by simply removing the cover. Or with the Wireless Link maybe be set-up remotely.

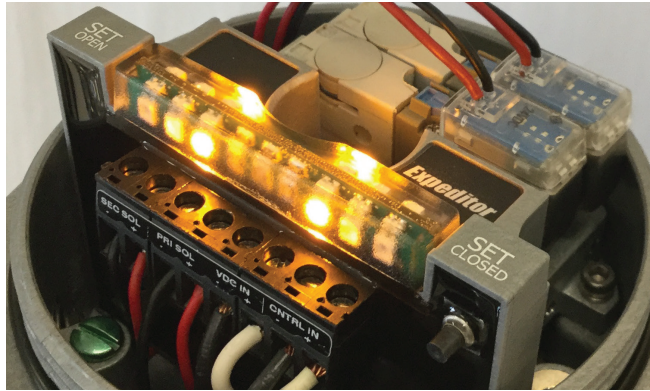

Intermediate position

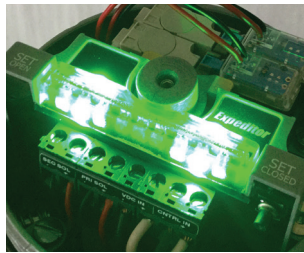

Open position

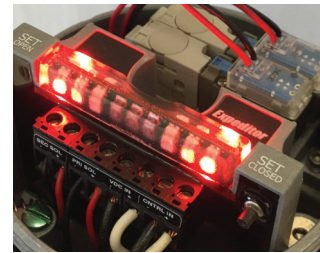

Closed position

Positioner operation

The expeditor's position control is directly proportional to the input signal from 20% to 80%. (7.2 mA to 16.8 mA). When the input signal is less than 20% (7.2 mA), the actuator is driven closed. When the input signal is greater than 80% (16.8 mA), the actuator is driven open.

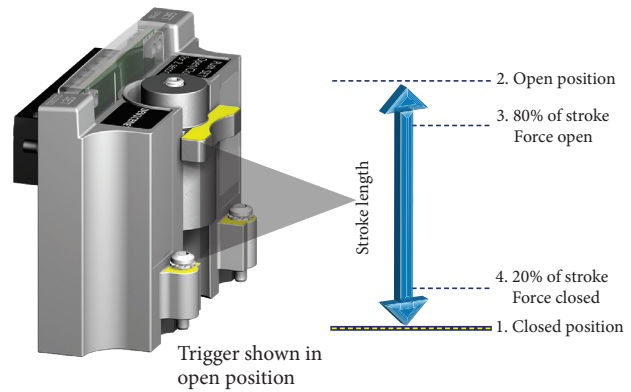
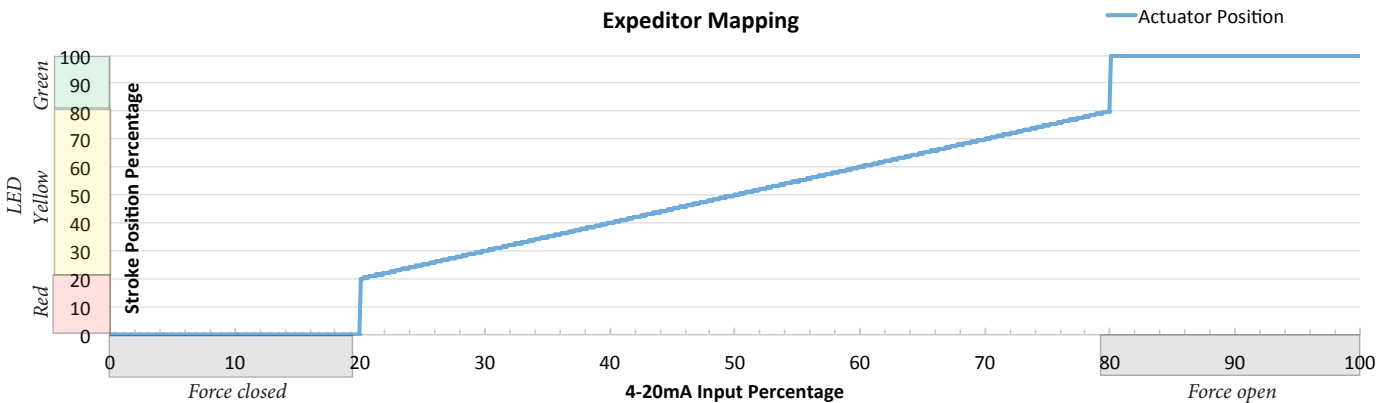
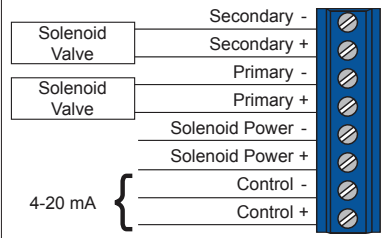
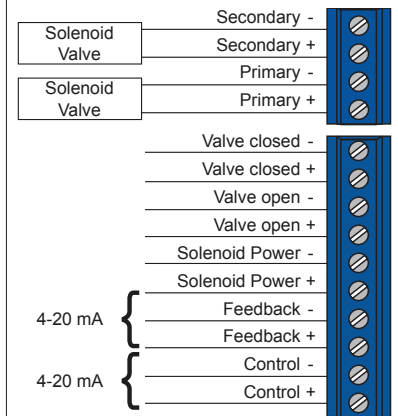

Fig. 1.



Expeditor module

Expeditor for standard stroke	
Expeditor (80S & 80W) with valve size (SMA)	
Solenoid voltage	24 VDC
Position control (AO)	(1) 4-20 mA loop, 9 - 30 VDC
LED states (see "Fig. 1" on page 8)	
Red	Closed state (current position ≤ 20% of full scale)
Yellow	Intermediate state (20% < current position < 80%)
Green	Open state (current position ≥ 80% of full scale)
Control signal (see "Fig. 1" on page 8)	
Force closed	4-20 mA signal ≤ 20% of full scale
Linear intermediate control	20% < 4-20 mA signal < 80%
Force open	4-20 mA signal ≥ 80% of full scale
Wiring diagram (80S & 80W) for valve with standard stroke 	
Expeditor Specify pneumatic valve option 2KS	

Expeditor for long stroke	
Expeditor (81S & 81W) with valve size (LMA)	
Solenoid voltage	24 VDC
Position control (AO)	(1) 4-20 mA loop, 9 - 30 VDC
Position feedback (AI)	(1) 4-20 mA loop, 9 - 30 VDC
Position feedback (DI)	(2) Discrete inputs
LED states (see "Fig. 1" on page 8)	
Red	Closed state (current position ≤ 20% of full scale)
Yellow	Intermediate state (20% < current position < 80%)
Green	Open state (current position ≥ 80% of full scale)
Control signal (see "Fig. 1" on page 8)	
Force closed	4-20 mA signal ≤ 20% of full scale
Linear intermediate control	20% < 4-20 mA signal < 80%
Force open	4-20 mA signal ≥ 80% of full scale
Wiring diagram (81S & 81W) for valve with long stroke 	
Expeditor Specify pneumatic valve option 2KS	

Expeditor specifications

Two three-way, two-position spring return pneumatic valves quickly and precisely operate valves to specific position in less than two seconds.

Expeditor pneumatic specifications	
2K (80_, 81_) solenoid valve	
Configuration	(2) 3-way, 2-position, spring return
Porting	1/8" NPT (stainless steel reinforced)
Operating pressure	25 psi to 140 psi
Operating voltage	24 VDC
Solenoid power	1.0 watt
Flow rating	0.2 Cv (Kv = 0.17 based on flow m3/hr)
Operating temperature	-10° C to 50° C (0° F to 122° F)
Filtration requirements	40 microns
Inrush	Negligible

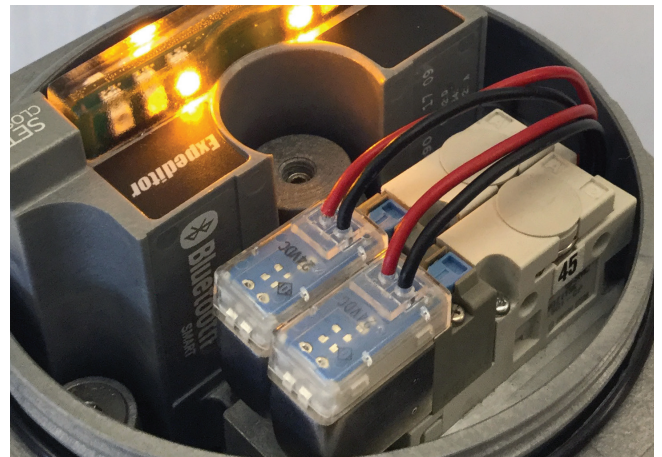

Pneumatic control and other specifications

Three-way, two-position spring return pneumatic valve features a standard Cv of 0.1 or 0.2, operating most actuators in less than two seconds. The valve is completely isolated from the environment enabling pneumatic control to be located in the field with no threat of contamination.

Solenoid valve

This high flow solenoid valve operates at low power and is well-suited for most applications. It features a convenient manual override for stroking during set-up and commissioning.

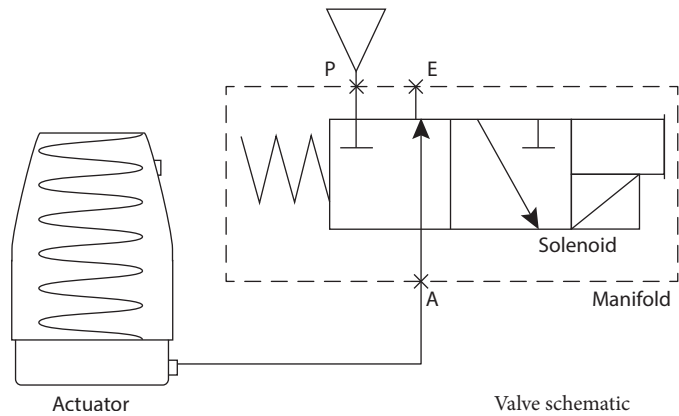
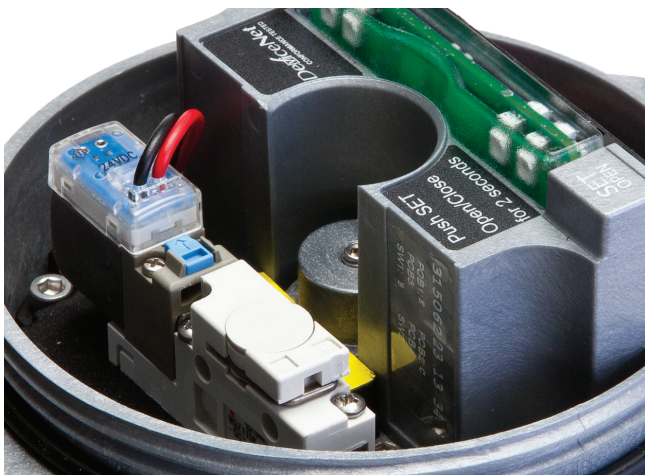

General pneumatic valve specifications

Configuration	3-way, 2-position, spring return
Type	Direct acting
Porting	1/8" NPT (stainless steel reinforced)
Operating pressure	25 psi to 120 psi (1.72 to 9.65 bar)
Operating life	1 million cycles
Manual override	Internal momentary

Solenoid coil specifications

1K (33_, 92_, 96_, 97_)	
Operating voltage	24 VDC
Power consumption	1.0 watt
Flow rating	0.2 Cv (Kv = 0.17 based on flow m3/hr)
Operating temperature	-10° C to 50° C (14° F to 122° F)
Filtration requirements	40 microns
1M (33_)	
Operating voltage	120 VAC
Power consumption	1.0 watt
Flow rating	0.2 Cv (Kv = 0.17 based on flow m3/hr)
Operating temperature	-10° C to 50° C (14° F to 122° F)
Filtration requirements	40 microns
1N (33_)	
Operating voltage	20 - 125 VAC; 20 - 55 VDC
Power consumption	12 mA @ 20 - 125 VAC (1.0 watt typical) 20 mA @ 20 - 55 VDC (0.5 watts typical)
Flow rating	0.1 Cv (Kv = 0.08 based on flow m3/hr)
Operating temperature	-20° C to 60° C (-4° F to 140° F)
Filtration requirements	50 microns
1N (92_, 96_, 97_)	
Operating voltage	24 VDC
Power consumption	0.5 watts
Flow rating	0.1 Cv (Kv = 0.08 based on flow m3/hr)
Operating temperature	-20° C to 60° C (-4° F to 140° F)
Filtration requirements	50 microns
1N (45_)	
Operating voltage	18 - 28 VDC
Power consumption	0.3 watts
Flow rating	0.1 Cv (Kv = 0.08 based on flow m3/hr)
Operating temperature	-20° C to 60° C (-4° F to 140° F)
Filtration requirements	50 microns
Entity parameters	Ui=28 VDC, Ii=120 mA, Ci=3 nF, Li=0 mH, Pi=0.84 W

Specifications

Materials of construction

Cover	Clear polycarbonate
Housing and mounting manifold	Fiber reinforced polycarbonate
Fasteners	Stainless steel
Valve manifold	Integral with stainless steel reinforced NPT
Trigger system (magnetic)	Polysulfone with black chromated zinc reinforcement

Position sensor system

Accuracy	1.0 mm (.040")
Repeatability	0.5 mm (.020")
Setting buffer	Open: 25% of stroke length Closed: 25% of stroke length up to 3.2 mm (.125")
Deadband	Open: 30% of stroke length (variable; based on stroke length) Closed: 30% of stroke length or 3.8 mm (.150") (whichever is less)

Temperature ratings (pneumatic valve dependent)

Operating temperature	11S, _NS, _KS, _MS	-20° C to 60° C (-4° F to 140° F) -10° C to 50° C (14° F to 122° F)
-----------------------	--------------------	--

Operating life	Over 1 million cycles
----------------	-----------------------

Warranty

Electronic module	Five years
Mechanical components	Two years

Ratings

Nonincendive <i>(Ex n, Zone 2 or Class I and II, Div. 2)</i>	PI models*
Intrinsically safe <i>(Ex ia, Zone 0 or Class I and II, Div. 1)</i>	Function 45*

Enclosure protection

Type 4, 4X and 6	All models
Ingress Protection 66 and 67	All models

Approvals*	See stonel.com/approvals
------------	--

* Only models listed on valmet.com/flowcontrol website are approved per specific rating.

Dimensions

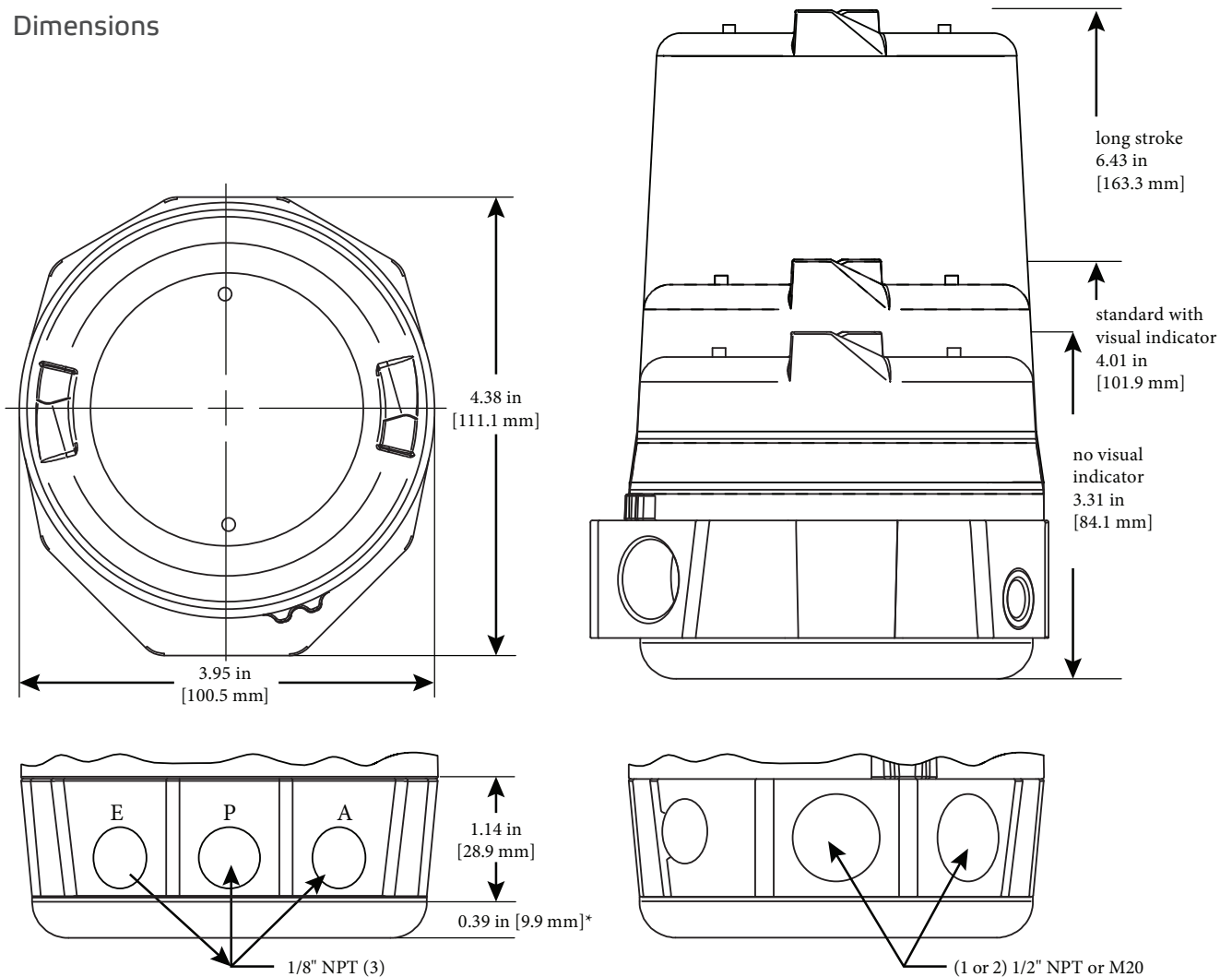

*Part of mounting system

Model selector			
SERIES			
PI Nonincendive or intrinsically safe			
FUNCTIONS			
Sensors modules		Valve communication Terminals (VCTs)	
33S	(2) SST NO switching sensors [select pneumatic valve option 1KS, 1MS, 1NS or 11S]	92S	DeviceNet™ [select pneumatic valve option 1KS, 1NS or 11S]
45S	(2) NAMUR sensors (EN 60947-5-6; I.S.) [select pneumatic valve option 1NS or 11S]	92W	DeviceNet™ with Wireless Link [select pneumatic valve option 1KS, 1NS or 11S]
		96S	AS-Interface [select pneumatic valve option 1KS, 1NS or 11S]
		97S	AS-Interface with extended addressing [select pneumatic valve option 1KS, 1NS or 11S]
		97W	AS-Interface with extended addressing and Wireless Link [select pneumatic valve option 1KS, 1NS or 11S]
Expeditor, standard stroke		Expeditor, long stroke	
80S	(1) 4-20mA AO for position control [select pneumatic option 2KS and valve size SMA]	81S	(1) 4-20mA AO for position control with (1) 4-20mA AI and (2) 24V DI for position feedback [select pneumatic option 2KS and valve size LMA]
80W	(1) 4-20mA AO for position control [select pneumatic option 2KS and valve size SMA]	81W	(1) 4-20mA AO for position control with (1) 4-20mA AI and (2) 24V DI for position feedback [select pneumatic option 2KS and valve size LMA]
PNEUMATIC VALVE / TEMPERATURE			
-20° C to 60° C / 0.1 Cv		-10° C to 50° C / 0.2 Cv	
11S	No pneumatic valve	1KS	Three-way 24 VDC
1NS	Three-way voltage / power depends on function	1MS	Three-way 120 VAC
		2KS	Dual three-way 24 VDC
ENCLOSURE			
A	North American (NEC/CEC)		
V	International (IEC)		
L	Other		
CONDUIT/CONNECTORS			
Standard	Mini-connectors		Micro-connectors (M12)
01 (1) ½" NPT	10 (1) 4-pin	13 (1) 4-pin	
02 (2) ½" NPT	11 (1) 5-pin	14 (2) 4-pin	
04 (1) M20	19 (1) 6-pin	15 (1) 5-pin	
05 (2) M20		17 (1) 6-pin	
08 (1) cable glands			
09 (2) cable glands			
VISUAL INDICATOR			
R	Green open		0 No mechanical indication
VALVE SIZE			
SA	Standard stroke - ¼" to 2" (3.2 mm to 28.5 mm; ½" to 1 ⅛" stroke)		
LA	Long stroke - ¼" to 6" (3.2 mm to 66.8 mm; ½" to 2 ⅝" stroke)		
Model number example			
PI	33S	1KS	A 01 R SA
MODEL NUMBER		OPTIONAL PARTNERSHIP ID	
Mounting hardware required and sold separately.		Some models may include 5-digit identification suffix.	

Valmet Flow Control Inc.

Stonel product center

26271 US Hwy 59, Fergus Falls, MN 56537 USA .

Tel. +1 218 739 5774.

sales.stonel@valmet.com

valmet.com/flowcontrol

Subject to change without prior notice.

Neles, Neles Easyflow, Jamesbury, Stonel, Valvcon and Flowrox, and certain other trademarks, are either registered trademarks or trademarks of Valmet Oyj or its subsidiaries in the United States and/or in other countries.

For more information www.neles.com/trademarks

